

UNIVERSITY OF TORONTO



3 1761 00815529 3

HANDBOUND
AT THE



UNIVERSITY OF



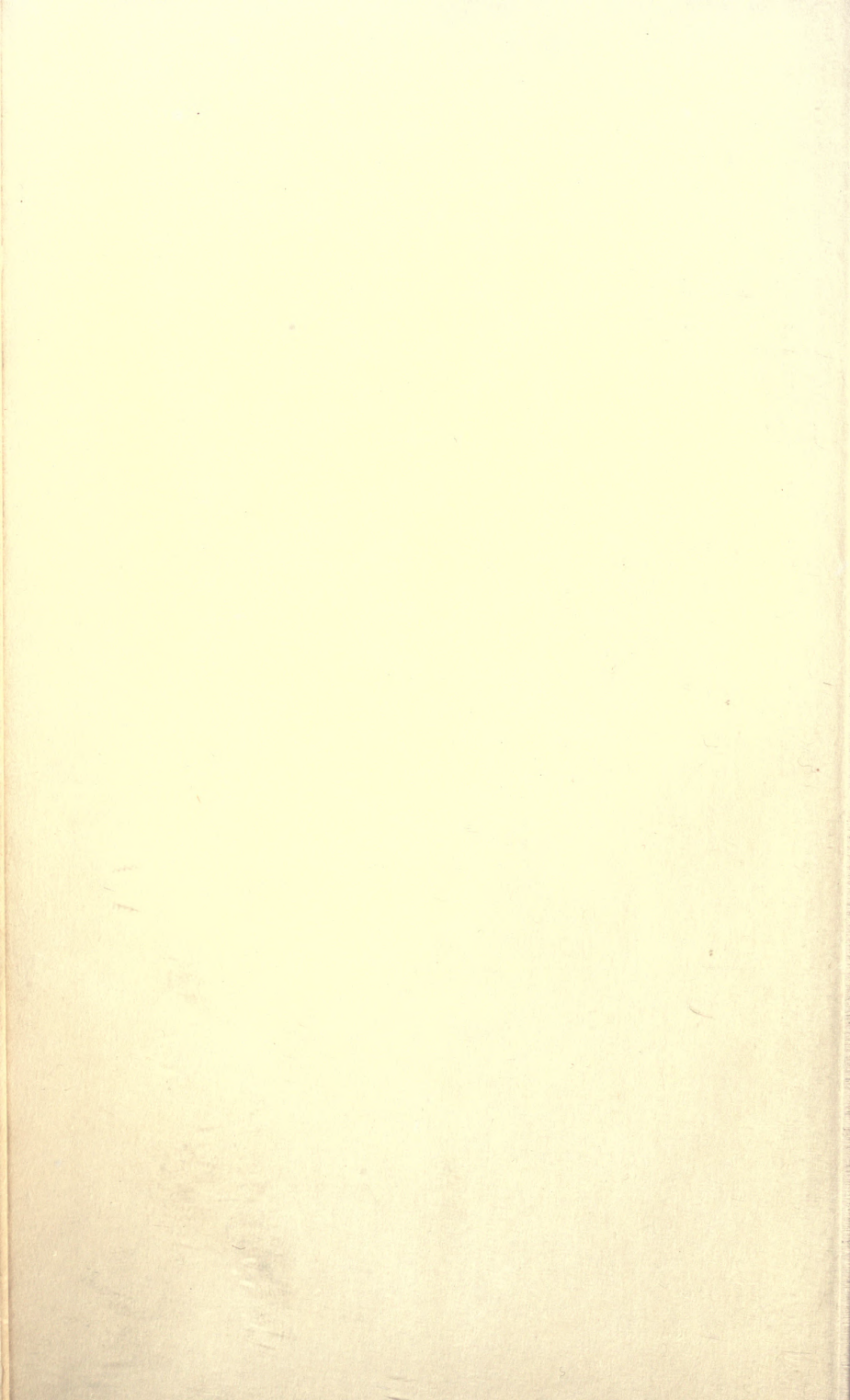

1

LIBRARY
OF ILLUSTRATED
STANDARD SCIENTIFIC WORKS.

UNDER this Title the Publisher has already issued seven volumes, as detailed in the following Prospectus, all printed in a fine type, in the octavo form, and illustrated in the most efficient manner.

It is intended that this Series shall embrace Works in the various branches of Science by the most distinguished men in their respective departments. Several are now in actual preparation.

No expense has been, nor will be spared, to make this series of Works, worthy of the support of the Scientific public.

219, REGENT STREET, LONDON.

H. BAILLIERE.

I.

PROFESSOR MULLER'S

PRINCIPLES OF PHYSICS AND METEOROLOGY.

WITH 530 WOODCUTS AND 2 COLOURED ENGRAVINGS. 8vo. 18s.

II.

PROFESSOR WEISBACH'S

MECHANICS OF MACHINERY AND ENGINEERING.

VOLS. I. AND II WITH 900 WOODCUTS. £1. 19s.

III.

PROFESSOR KNAPP'S

TECHNOLOGY; OR,

CHEMISTRY APPLIED TO THE ARTS AND TO MANUFACTURES.

EDITED BY DR. E. RONALDS AND DR. T. RICHARDSON,

Vols. I. and II. splendidly Illustrated. Price £2. 2s.

IV.

QUEKETT (JOHN).

PRACTICAL TREATISE ON THE USE OF THE MICROSCOPE.

With Steel and Wood Engravings. 8vo. 21s.

V.

PROFESSOR GRAHAM'S

ELEMENTS OF CHEMISTRY, WITH ITS APPLICATION IN THE ARTS.

Second Edition, with upwards of 1200 Pages of Letter-Press and innumerable Woodcuts.

IN THE PRESS.

A COMPLETE TREATISE ON METALLURGY,
AND THE CHEMISTRY OF THE METALS.

BY DR. E. RONALDS AND DR. T. RICHARDSON,

Editors of "KNAPP'S TECHNOLOGY."

FORMING VOL. III. OF WEISBACH'S MECHANICS.

THE STEAM ENGINE.

BY PROFESSOR L. GORDON, OF GLASGOW.

Giving all the Improvements to the Present Time. Beautifully Illustrated on Steel and Wood.

VOL. I. OF THE SERIES.

PRINCIPLES
OF
PHYSICS AND METEOROLOGY.
BY PROFESSOR MULLER.

Comprising nearly 600 pages of letter-press illustrated with upwards of 530 Wood Engravings and 2 Coloured Plates. 8vo. 18s. cloth.

SPECIMENS OF THE WOOD ENGRAVINGS.

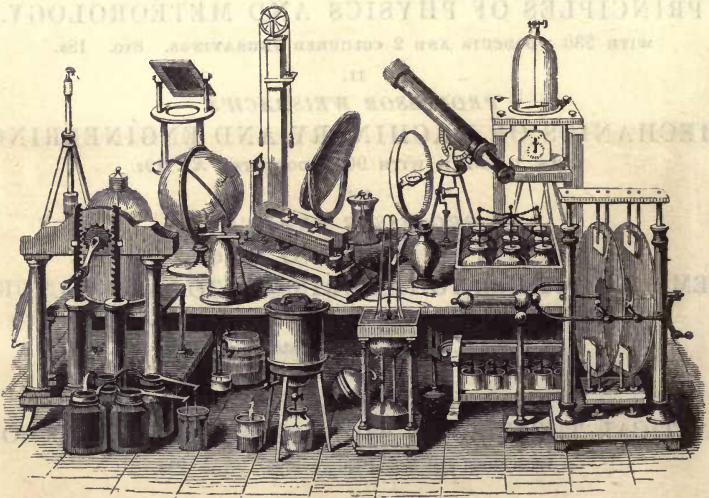

“In the work before us, the first thing which strikes us is the profusion of wood-cuts beyond what we should have imagined any publisher could furnish at the price—and very good cuts. The matter of the work is sound, and ranges over the subjects well. The manner is popular, and the author, though a mathematician, introduces only formulæ to look at now and then, without algebraic processes. We strongly recommend this work, particularly for the libraries of schools, mechanics’ institutes, and the like. Such libraries often contain a shelf of books similar in plan to the present, and a great deal too similar in detail to one another. The present volume would be a refreshing variety; and contains, at the same time, excellent reading and reference for those who are to have but one book on the subject.”—*Athenæum*, Nov. 1847.

H. BAILLIERE, PUBLISHER, 219, REGENT STREET, LONDON.

VOL. II. V. AND VIII. OF THE SERIES.

PRINCIPLES

OF

THE MECHANICS

OF

MACHINERY AND ENGINEERING.

BY PROFESSOR JULIUS WEISBACH.

2 Vols. illustrated with upwards of 900 Wood Engravings. 8vo. £1. 19s.

Vol. II. separately, 1848. 18s.

VOL. III, AND LAST, WILL BE

THE STEAM ENGINE,

BY PROFESSOR GORDON, OF GLASGOW.

Giving all the Improvements up to the present day.

SPECIMENS OF THE WOOD ENGRAVINGS.

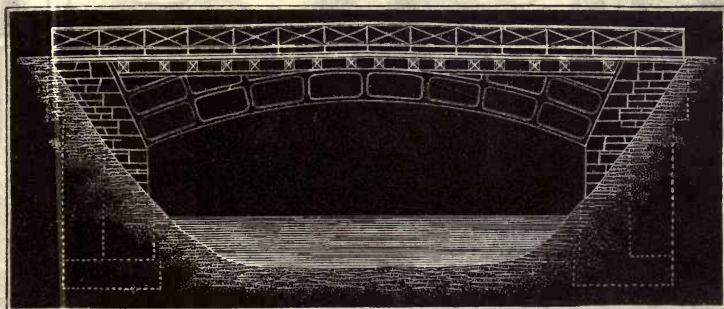
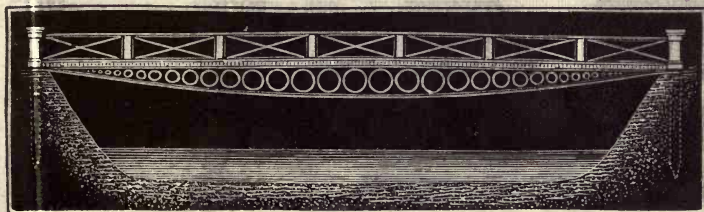

"The most valuable contribution to Practical Science that has yet appeared in this country, the Work embraces not only the subjects of Statics and Dynamics, but also Hydrostatics, Hydraulics and Pneumatics. The Work is beautifully got up as to Letterpress and Illustrations,—the Diagrams being the most picturesque that we have seen."—*Athenæum*, March 11, 1848.

"This Work is one of the most interesting to mathematicians that has been laid before us for some time; and we may safely term it a *scientific gem*."—*The Builder*, November 27, 1847.

H. BAILLIÈRE, PUBLISHER, 219, REGENT STREET, LONDON.

VOLS. III. & IV. OF THE SERIES.

TECHNOLOGY;
OR,
CHEMISTRY
APPLIED TO THE ARTS AND TO MANUFACTURES.
BY F. KNAPP.

TRANSLATED AND EDITED BY
DR. EDMUND RONALDS,
LECTURER ON CHEMISTRY AT THE MIDDLESEX HOSPITAL.

AND DR. THOMAS RICHARDSON,
OF NEWCASTLE.

2 Vols. 8vo. With 500 Illustrations. £2. 2s. Vol. II, separately, 1848. £1. 1s.

SPECIMEN OF THE WOOD ENGRAVINGS.



“In a manufacturing nation such as England, the application of Scientific Research to the Arts ministering to the requirements of the consumer, is the prime object of every practical employer of skilled labour, who would not be left behind in the race of improvement; and we need not insist upon the vast number of the Arts involving in particular the processes of Chemistry. The Editors of this Work have conferred a vast boon on the capitalist artificers of England.”—*Westminster Review*, April 1848.

H. BAILLIERE, PUBLISHER, 219, REGENT STREET, LONDON.

ELEMENTS OF CHEMISTRY;

INCLUDING THE

APPLICATIONS OF THE SCIENCE IN THE ARTS.

BY PROFESSOR T. GRAHAM, F.R.S.

CORRESPONDING MEMBER OF THE FRENCH INSTITUTE.

Second Edition, comprising above 1200 pages of letter-press, and illustrated with numerous Wood Engravings. 8vo.

Parts I, II and III are out.

SPECIMEN OF THE WOOD ENGRAVINGS.

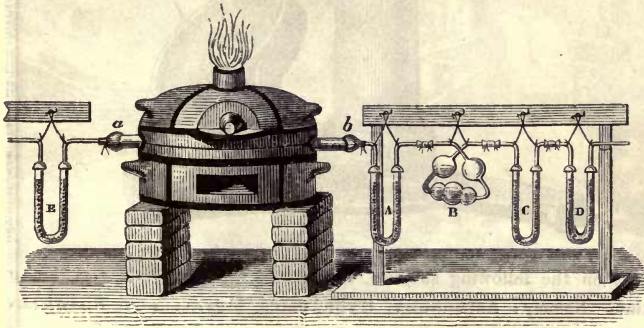
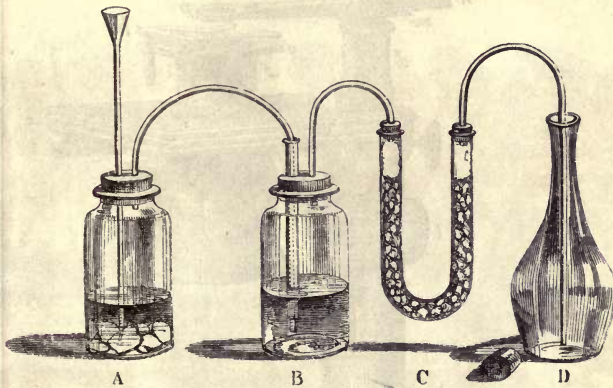

VOL. VI. OF THE SERIES.

PRACTICAL TREATISE

ON THE USE OF THE

MICROSCOPE.

BY JOHN QUEKETT, Esq.,

ASSISTANT CONSERVATOR OF THE MUSEUM OF THE ROYAL COLLEGE OF SURGEONS OF ENGLAND.

Comprising nearly 500 pages of letter-press with 8 Steel Plates and numerous Wood Engravings, 8vo. £1. 1s.

SPECIMEN OF THE WOOD ENGRAVINGS.

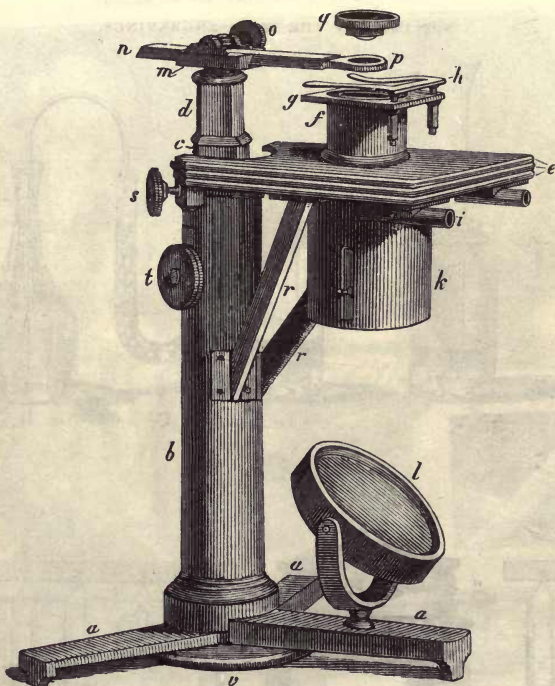

Works on the following subjects, to be comprised in this Series, are in course of preparation. Namely: ASTRONOMY, HYDRAULICS, METALLURGY, PHARMACY and THE HORSE, CATTLE, THE STEAM ENGINE, &c. &c.

H. BAILLIERE, PUBLISHER, 219, REGENT STREET, LONDON.

A COMPLETE TREATISE
ON
METALLURGY
AND THE
CHEMISTRY OF THE METALS.

BY DR. E. RONALDS,
LECTURER ON CHEMISTRY TO THE MIDDLESEX HOSPITAL.
AND DR. THOMAS RICHARDSON,
OF NEWCASTLE-UPON-TYNE.

To form 3 Vols. 8vo. Well Illustrated.

SPECIMEN OF THE WOOD ENGRAVINGS.



IMPORTANT WORKS

PUBLISHED BY

HIPPOLYTE BAILLIERE.

ODONTOGRAPHY;
OR, A TREATISE

ON THE COMPARATIVE ANATOMY OF THE TEETH,
THEIR PHYSIOLOGICAL RELATIONS, MODE OF DEVELOPMENT,
AND MICROSCOPICAL STRUCTURE IN THE VERTEBRATE ANIMALS.

BY RICHARD OWEN, F.R.S.

CORRESPONDENT OF THE ROYAL ACADEMY OF SCIENCES, PARIS AND BERLIN; HUNTERIAN PROFESSOR TO THE ROYAL COLLEGE OF SURGEONS, LONDON.

2 vols. royal 8vo. containing 168 Plates, half bound russia, £6. 6s. London, 1840—45.
A few copies of the Plates have been printed on India Paper, 2 vols. 4to. £10. 10s.

NATURAL HISTORY OF THE MAMMALIA.

BY G. R. WATERHOUSE.

CORRESPONDING MEMBER OF THE PHILOMATIC SOCIETY OF PARIS; AND ASSISTANT IN THE DEPARTMENT OF MINERALOGY AND GEOLOGY OF THE BRITISH MUSEUM.

2 Vols. 8vo. with Illustrations on Steel and Wood, each Vol. Col. £1. 14s. 6d. Plain, £1. 9s.

VOL. I.—MARSUPIATA.

VOL. II.—RODENTIA.

THE NATURAL HISTORY OF MAN;

COMPRISING INQUIRIES INTO THE MODIFYING INFLUENCE OF PHYSICAL AND MORAL AGENCIES ON THE DIFFERENT TRIBES OF THE HUMAN LIFE.

BY JAMES COWLES PRICHARD, M.D. F.R.S. M.R.I.A.

CORRESPONDING MEMBER TO THE NATIONAL INSTITUTE, OF THE ROYAL ACADEMY OF MEDICINE, AND OF THE STATISTICAL SOCIETY OF FRANCE; MEMBER OF THE AMERICAN PHILOSOPHICAL SOCIETY, ETC.

Third Edition, enlarged, with 50 coloured and 5 plain illustrations, engraved on Steel, and 97 engravings on Wood, royal 8vo. elegantly bound in cloth. £1. 16s. London, 1848.

APPENDIX to the FIRST and SECOND EDITIONS OF THE NATURAL HISTORY OF MAN.
Large 8vo. with 6 coloured plates, each 3s. 6d. London, 1845 and 1848.

SIX ETHNOGRAPHICAL MAPS, as a Supplement to the Natural History of Man, and to the Researches into the Physical History of Mankind. Folio coloured and 1 sheet of Letter-press, 21s. bound in cloth boards, 24s. London, 1845.

ILLUSTRATIONS to the RESEARCHES into the PHYSICAL HISTORY of MANKIND. Atlas of 44 coloured and 5 plain plates, engraved on Steel, large 8vo. half-bound, 18s. London, 1841.

THE PLANT; A BIOGRAPHY.

IN A SERIES OF POPULAR LECTURES ON BOTANY.

BY M. J. SCHLEIDEN, M.D.

PROFESSOR AT THE UNIVERSITY OF JENA.

TRANSLATED WITH NOTES

BY ARTHUR HENFREY, F.L.S.

LECTURER ON BOTANY AT ST. GEORGE'S HOSPITAL.

With 5 Coloured Plates and 13 Illustrations on Wood. 8vo. 15s.

"As an introduction to the philosophical study of the vegetable kingdom, we can cordially recommend this volume. * * * * No one can for a moment doubt that this is the work of a man of genius, a profound thinker, thoroughly imbued with the spirit that should actuate all who would seek or apply the truth wherever it may be found. * * * * The translation, on the whole, demands our warm commendation."—*Athenæum*, September 30, 1848.

LIBRARY

OF

ILLUSTRATED

STANDARD SCIENTIFIC WORKS.

VOL. VI.

QUEKETT'S

PRACTICAL TREATISE

ON THE USE OF THE

MICROSCOPE.

London :

HIPPOLYTE BAILLIERE, PUBLISHER,
219, REGENT STREET.

PARIS: J. B. BAILLIERE, 13, RUE DE L'ECOLE DE MEDECINE.

1848.

GERBER AND GULLIVER.

ELEMENTS of the **GENERAL** and **MINUTE ANATOMY** of **MAN** and the **MAMMALIA**; chiefly after Original Researches. By Professor Gerber. To which is added an Appendix, comprising Researches on the Anatomy of the Blood, Chyle, Lymph, Thymous Fluid, Tubercle, and Additions, by C. Gulliver, F.R.S. In 1 vol. 8vo. Text, and an Atlas of 34 plates, engraved by L. Aldous. 2 vols. 8vo. cloth boards, 1*l.* 4*s.* 1842.

VOGEL AND DAY.

THE PATHOLOGICAL ANATOMY of the **HUMAN BODY**. By Julius Vogel, M.D. Translated from the German, with additions, by George E. Day, M.D. Illustrated with upwards of 100 plain and coloured engravings, 8vo. cloth, 18*s.* London, 1847.

Luchett on the Microscope.

*Prof's improved Compound and Simple
Microscope.*

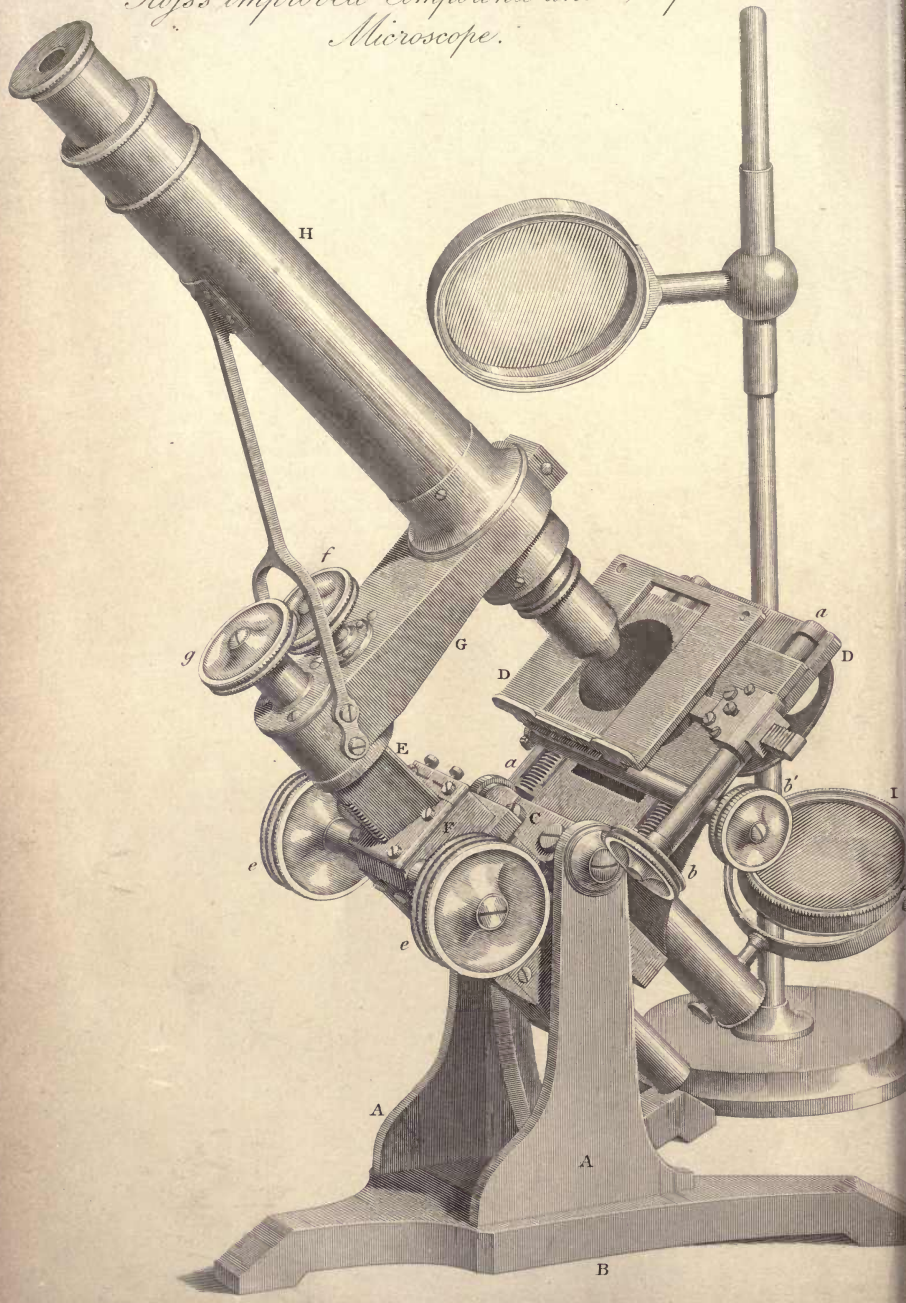

C. Varley, del.

G. Gladwin, sculp.

A

PRACTICAL TREATISE

ON THE USE OF THE

MICROSCOPE,

INCLUDING THE

DIFFERENT METHODS OF PREPARING AND EXAMINING
ANIMAL, VEGETABLE, AND MINERAL STRUCTURES.

BY

JOHN QUEKETT,

ASSISTANT CONSERVATOR OF THE MUSEUM AND DEMONSTRATOR OF MINUTE ANATOMY
AT THE ROYAL COLLEGE OF SURGEONS OF ENGLAND.

ILLUSTRATED WITH NINE PLATES AND TWO HUNDRED AND FORTY-ONE
WOOD ENGRAVINGS.

London:

HIPPOLYTE BAILLIERE, PUBLISHER,
219, REGENT STREET.

PARIS: J. B. BAILLIERE, 13, RUE DE L'ECOLE DE MEDECINE.

1848.

$$\begin{array}{r} 8151 \\ \hline 24 \overline{) 11190} \end{array}$$

6

TO

JOSEPH JACKSON LISTER, ESQ., F.R.S., &c.,

TO WHOSE LABOURS IN PERFECTING THE

Achromatic Compound Microscope,

SCIENCE IN ENGLAND IS SO DEEPLY INDEBTED,

THIS TREATISE IS DEDICATED,

WITH FEELINGS OF RESPECT,

BY HIS FRIEND,

THE AUTHOR.

3

PREFACE.

THE rapid advances which have been made in modern times, towards a correct knowledge of the intimate structure of animate and inanimate beings, by the employment of the Microscope, have given to this instrument an importance second only to that of the Telescope. By its agency alone have crude notions and theories been swept away, and science in civilized countries made to stand on a firmer basis. In this land of machinery and manufactures, artists have not been found wanting to devote their time and talents to the conversion of what might once have been an amusing instrument or a toy, into one of the most powerful auxiliaries that can be employed in scientific research. In proportion to its use, so has been the demand for improvement in its construction, and both amateur and optician have laboured together to bring it to its present state of perfection, the former, in many cases, furnishing the means to enable the latter to carry out their designs. In the present day, so urgent has been the call for Achromatic Microscopes in England, that the demand has far exceeded the supply of information on matters connected with their construction and use; since the works of Sir D. Brewster, Dr. Goring, and Mr. Pritchard, no treatises of a practical nature have been published in this country. The writings of Mr. Pritchard, although very excellent, are chiefly confined to the instruments and apparatus of his own manufacture, consequently, persons who are in possession of microscopes constructed by others (and these by far the most

numerous class) are still without a guide to their management; to remedy this deficiency, the present work has been undertaken. The principal aim the Author has had in view has been to furnish the uninitiated with a concise and practical account, firstly, of the Microscope as known in former years; secondly, of the different forms of instruments now generally employed; thirdly, of the methods of applying the same to scientific inquiry; and, lastly, of the various plans of preparing, mounting, and examining animal, vegetable, and mineral substances, together with a classification of a few characteristic and interesting specimens that may be selected from the great volume of Nature.

It was, at first, the intention of the writer to have included in the present Treatise the methods of dissecting and injecting, as well as many very important matters, purely of an anatomical nature; but he has found it advisable to defer these and all others relating exclusively to physiological science to a separate work, which he hopes at a subsequent period to lay before the medical profession, to whom the Microscope has now become indispensable as an educational instrument.

The different modes of preparing and examining Microscopic objects are chiefly the result of the Author's own experience, but as it would be next to impossible for one individual to be fully conversant with all these subjects, he begs to state that he will always be glad to receive from fellow-labourers any hints bearing on matters relating to the Microscope, and ready to acknowledge the source from whence such information may have been derived. In order to render the matters treated of clear and intelligible to the general reader, as many technicalities as possible have been avoided, and the simplest language made use of; which will account for the plainness of style and composition.

It may be remarked that the name of Mr. Ross occurs more frequently than that of any other optician; this has arisen from the very valuable papers published by him, from which the Author has made copious extracts; he embraces this opportunity of acknowledging the kind assistance afforded him on all occasions by Messrs. Powell and Lealand, Mr. Ross, and Messrs. Smith and Beck. He would here, also, beg to tender his best thanks to Dr. Pereira, Mr. Bowerbank, Mr. Jackson, and other gentlemen who have obligingly aided him with much useful information during the progress of the book, as well as to the artists, Messrs. Leonard and Aldous, and the wood engravers, Messrs. Vasey and Joyce, for the able manner in which their part of the work has been executed.

In conclusion, the Author trusts that his endeavours may not be unavailing in affording assistance to those who are engaged in Microscopic investigations; and should his efforts be conducive, in the slightest degree, to the promotion of scientific research, the end for which he has laboured will be fully accomplished.

15, DORCHESTER PLACE,
BLANDFORD SQUARE,
Nov. 11th, 1848.

Faint, illegible text, likely bleed-through from the reverse side of the page.

1871
1872
1873
1874
1875
1876
1877
1878
1879
1880
1881
1882
1883
1884
1885
1886
1887
1888
1889
1890
1891
1892
1893
1894
1895
1896
1897
1898
1899
1900

CONTENTS.

PART I.

MECHANICAL ARRANGEMENTS.

	Page
HISTORY OF THE MICROSCOPE	1
Hooke's microscope	4
Leeuwenhoek's microscope	6
Bonnani's microscope	8
Gründelius' microscope	ib.
Newton's microscope	9
Stephen Gray's water microscope	ib.
————— reflecting microscope	10
Wilson's pocket microscope	11
————— opaque microscope	12
Marshall's compound microscope	13
Lieberkuhn's microscope	15
————— microscope for injections	16
————— anatomical microscope	18
Culpeper's compound microscope	20
Cuff's microscope	22
George Adams' microscope	23
————— junr., microscope	24
Withering's botanical microscope	25
Jewel lenses	27
Invention of doublet	28
Herschell's doublet	29
Wollaston's doublet	30
Holland's triplet	31
History of compound achromatic microscope	32
Tulley's microscope	37
Lister's discoveries	39
Adjustment of achromatic object-glass	41
Improvers of achromatic microscope	44

CHAPTER I.

	Page
THE SIMPLE MICROSCOPE	47
Pocket magnifiers	ib.
Coddington lens	49
Author's dissecting microscope	50
Watchmaker's eye-glass	ib.
Powell and Lealand's dissecting microscope	52
Lister's method of mounting pocket magnifier	54
Ross's portable dissecting microscope	55
Slack's dissecting microscope	56
Ross's simple and compound microscope	59
Valentine's microscope	60
Smith and Beck's simple microscope	63
Magnifying powers employed	64
Wollaston's doublet	65
Holland's triplet	66

CHAPTER II.

COMPOUND MICROSCOPE	67
Mechanical arrangements	68
Messrs. Powell and Lealand's large achromatic microscope	74
————— smaller microscope	78
————— portable microscope	79
Ross's compound microscope	82
————— portable compound microscope	85
Messrs. Smith and Beck's large achromatic microscope	88
Mr. Alfred White's lever stage	90
Messrs. Smith and Beck's smaller compound microscope	91
————— achromatic microscopes for students	92
Varley's microscope	95
Dancer's microscope	97

CHAPTER III.

ACCESSORY INSTRUMENTS	98
The diaphragm	99
Dark chamber	100
Wollaston condenser	ib.
Achromatic condenser	101
Polarizing apparatus	104
Condensing lens	106
Lieberkuhn	110
Side reflector	111

CONTENTS.

xiii

Page

Dark stops or wells	112
Forceps	ib.
Animalcule cages	114
Fishing tubes for animalcules	117
Compressorium	121
Troughs for chara and polyps	124
Frog-plate	125
Fish-troughs	126
Plial-holder	127
Camera lucida	128
Prism	129
Indicator	130
Bonnet or hood for the compound body	131

CHAPTER IV.

THE LAMP	133
Chimney shade	137
Oil	138
Jatropha oil	ib.
Cleaning lamps	ib.
Portable candle-lamp	139
To clean chimneys of lamps	141

CHAPTER V.

ON THE MAGNIFYING POWERS USED WITH SIMPLE AND ACHROMATIC COMPOUND MICROSCOPES	142
-----------------------------------------------------------------------------------------	-----

PART II.

USE OF THE MICROSCOPE.

CHAPTER I.

PRELIMINARY DIRECTIONS	165
Position	ib.
Adjustment of the light	166
Transparent objects	ib.
Adjustment of the focus	167
Opaque objects	169

CHAPTER II.

	Page
ON THE ILLUMINATION OF OBJECTS	170
Transparent objects	ib.
Achromatic condenser or Eclairage	173
Direct light	177
Oblique light	178
Back-ground illumination	ib.

CHAPTER IIA.

OPAQUE OBJECTS	180
Lieberkuhn	183
Dark stops	185

CHAPTER III.

MICROMETER	189
Stage micrometer	191
Eye-piece micrometer	192
Cobweb micrometer	196
ON THE MEASUREMENT OF MICROSCOPIC OBJECTS	197
With the stage micrometer	ib.
By the micrometer eye-piece	198
To find the value of the lines in the negative eye-piece micrometer	ib.
To find the value of the divisions in the positive eye-piece micrometer	200
To find the value of each revolution of the screw, or parts of a revolution of the same, in the cobweb micrometer	201
Directions for the use of the eye-piece micrometer	202
To use the cobweb micrometer	203
Measurements of an object made by means of a stage micrometer and a Camera Lucida	ib.

CHAPTER IV.

ON THE METHODS OF OBTAINING THE MAGNIFYING POWER OF SINGLE AND COMPOUND MICROSCOPES	205
To convert Paris lines into English measure	210
To convert millimetres into English measure	ib.

CONTENTS.

xv

CHAPTER V.

	Page
CAMERA LUCIDA	210
Method of using the Camera Lucida with the microscope	212
Uses to which the Camera Lucida may be applied	213

CHAPTER VI.

ON THE POLARIZATION OF LIGHT	215
Origin of the term	ib.
Method of using the polarizing apparatus	218
Cause of the colours of polarized light	225
Advantages of polarized light to the microscopist	230

CHAPTER VII.

GONIOMETER	231
----------------------	-----

PART III.

MANIPULATION.

CHAPTER I.

Diamond for cutting glass	239
Writing diamonds	241

CHAPTER II.

ON CUTTING GLASS	242
Glass	ib.
Cutting-board	ib.
Process of cutting	243
Edging the slides	244
On cutting thin glass for covers	245
To cut circular and oval covers	246

CHAPTER III.

METHOD OF CEMENTING CELLS	247
Method of cementing cells without heat	ib.
Cementing cells by heat	248
To cement cells with Canada Balsam	250

CHAPTER IV.

	Page
METHOD OF MOUNTING OBJECTS IN FLUID	251
The thin glass cell	254
The concave cell	255
Drilled cells	259
Built up cells	260
Method of mounting objects in deep cells	262

CHAPTER V.

ON CEMENTS	267
Japanners' gold-size	ib.
Sealing-wax varnish	ib.
Asphaltum	ib.
Canada balsam	268
Marine-glue	ib.
Electrical cement	ib.
Diamond cement	269

CHAPTER VI.

ON PRESERVATIVE FLUIDS	270
Spirit and distilled water	ib.
Acetate of alumina	ib.
Goadby's fluids	ib.
Solution of creosote	271
Thwaites' fluid	ib.
Glycerine	ib.
Chromic acid	272
Salt and water	ib.
Naptha	273
General directions	ib.

CHAPTER VII.

METHOD OF MOUNTING OBJECTS IN CANADA BALSAM	274
Preliminary directions	ib.
Necessary apparatus	275
Canada balsam	ib.
Wooden forceps	276
Metal forceps	277
Needle-points	ib.
Spirit and solar oil-lamp	278
To mount sections of wood	ib.

CONTENTS.

xvii

	Page
Animal structures	280
Fossil infusoria, &c.	281
Foraminifera, &c.	282
Cleaning balsam from the slides	283

CHAPTER VIII.

METHOD OF MOUNTING OBJECTS IN THE DRY WAY	284
First method	285
Second method	ib.
Darker's method	289

CHAPTER IX.

MOUNTING OPAQUE OBJECTS	290
On discs	ib.
On cylinders	292
On slides	293
In cells	ib.
In pill boxes	295

CHAPTER X.

TO MAKE SECTIONS OF BONE AND TEETH	297
Mounting sections of bone	299
To make sections of teeth	301
To mount sections of teeth	302

CHAPTER XI.

TO MAKE SECTIONS OF SHELL AND OTHER HARD TISSUES	ib.
To make sections of hard vegetable tissues	304
To prepare siliceous skeletons of vegetables	305

CHAPTER XII.

TO MAKE SECTIONS OF WOOD	306
Method of making sections	309
Methods of mounting sections of wood	312
Chippings of wood	ib.
Sections of horns, hairs, &c.	313

CHAPTER XIII.

	Page
ON THE DISSECTION AND PREPARATION OF VEGETABLE AND ANIMAL STRUCTURES	314
Dissecting forceps	ib.
Scissors	315
Cutting forceps	316
Spring scissors	ib.
Method of sharpening scissors	317
Scalpels	ib.
Valentin's knife	318
Dissecting needles	319
Non-cutting instruments	320
Troughs	ib.
Loaded corks	321
Rests	322

CHAPTER XIV.

METHOD OF DISSECTING VEGETABLE AND ANIMAL TISSUES	323
Vegetable tissues	ib.
Animal tissues	324
Dissection of particular tissues	329
Nerve	ib.
Muscle	ib.
Tracheæ	330
Spiracles	331

CHAPTER XV.

METHODS OF EXHIBITING OBJECTS OF INTEREST	332
Circulation of the blood	ib.
Method of viewing the circulation in the vertebrata	335
Circulation of blood in the Frog	337
Method of viewing the circulation in the tongue of the Frog	339

CHAPTER XVI.

ON THE CIRCULATION IN PLANTS	341
Chara	342
Method of viewing the circulation	343
Tradescantia virginica—spiderwort	346
Penstemon	ib.
Groundsel	347
Vallisneria spiralis	ib.

CONTENTS.

xix

	Page
Best method of viewing the circulation	348
Method of cultivating Chara, Vallisneria, &c.	349
Habitat	351

CHAPTER XVII.

METHODS OF PROCURING INFUSORY AND OTHER ANIMALCULES	352
Localities	ib.
Apparatus	ib.
Method of obtaining Infusoria	354
Method of obtaining and of keeping Hydras	356
Desmidiæ	358
Localities for Infusoria	360
The locality of the wheel animalcule	362
Method of feeding Infusoria with carmine	ib.
Fossil Infusoria	363
Method of preparing fossil Infusoria	364

CHAPTER XVIII.

CLASSIFICATION OF THE MOST IMPORTANT MICROSCOPICAL OBJECTS	366
Vegetable tissues	367
Cuticles	ib.
Cellular tissue	ib.
Fibro-cellular tissue	368
Spiral vessels	ib.
Ducts of various kinds	ib.
Woody fibre	ib.
Fossil woods	369
Siliceous cuticles	370
Hairs	ib.
Pollen	ib.
Starch	371
Seeds	ib.
Ferns	372
Spores	ib.
Raphides	ib.
Hard tissues	373
Mosses	ib.
Alge	374
Miscellaneous structures of a fibrous character	ib.
Animal tissues	375
Siliceous skeletons of recent and fossil infusoria	ib.
Fossil infusoria	376
Sponges	377

	Page
Alcyonium	377
Gorgonia	378
Corals	379
Zoophytes	ib.
Insects	ib.
Eyes of insects, Arachnida, and Crustacea	380
Feet of insects, &c.	381
Hairs of insects, &c.	ib.
Parts about the mouth of insects, &c.	382
Parasitic insects	383
Method of obtaining the acarus or itch insect	385
Scales of insects	386
Spiracles and tracheæ of insects	387
Stings	ib.
Stomachs	388
Preparations from the higher animals	ib.
Blood	ib.
Bone	389
Teeth	391
Fossil teeth	ib.
Shell	392
Scales of fish	393
Hairs	395
Skin	397
Eyes	399
Muscular fibre	400
Mucous membrane	402
Epithelium	403
Method of viewing the ciliary movement	404
The basement membrane	405
Method of examining the surface of mucous membranes	406
Objects for polarized light	410
Selenite	411
Crystals of salts	412
Currents in fluids observed during their evaporation	413
Method of viewing the spiral fibres in the testa of the seeds of <i>Salvia</i> , <i>Collomia</i> , &c.	414
Minerals	416
Biniodide of mercury	417
Tongue of Whelk and Limpet	418

CHAPTER XIX.

METHODS OF EXAMINING MORBID STRUCTURES, &c.	420
-----------------------------------------------------	-----

CHAPTER XX.

	Page
TEST OBJECTS	422
Angle of aperture	426
Methods of measuring the angle of aperture	428
List of test objects	431
Bat's hair	432
Mouse hair	ib.
Hair of Dermestes	433
Scales of Hipparchia janira	434
Scales of Pontia brassica	ib.
Scales of Polyommatus Argiolus	ib.
Scales of Podura	435
Scales of Lepisma saccharina	436
Scales from the gnat's wing	ib.
Battledoor scale of Polyommatus Argiolus	ib.
Scale of Morpho Menelaus	437
Navicula Angulata	438
Navicula Spencerii	440
Nobert's tests	ib.
Method of examining test objects	442
Method of using the adjusting object-glass	443

CHAPTER XXI.

MISCELLANEOUS HINTS ON THE MANAGEMENT OF THE MICROSCOPE
AND MICROSCOPIC PREPARATIONS.

Apartment	447
To clean the optical part of the microscope	448
Glass slides, to clean	ib.
Cabinets and boxes for holding microscopic objects	ib.
Labelling slides	450

APPENDIX.

Legg's improved stage	451
Instrument for cutting circular covers of thin glass	452
Apparatus for collecting Infusoria	453

Faint, illegible text, possibly bleed-through from the reverse side of the page.

MECHANICAL APPARATUS

Faint, illegible text, possibly bleed-through from the reverse side of the page.

APPENDIX

Faint, illegible text, possibly bleed-through from the reverse side of the page.

PART I.

MECHANICAL ARRANGEMENTS.

A

PRACTICAL TREATISE

ON THE USE OF

THE MICROSCOPE.

HISTORY OF THE MICROSCOPE.

THE term microscope, derived from the two Greek words μικρος; small, and σκοπεω to view, and said to have been first suggested by Demisianus, is applied to an instrument which enables us to see distinctly and to investigate objects placed at a short distance from the eye, or to see such minute objects as, without its aid, would be invisible. The early history of this instrument, like that of many others of a scientific nature, is involved in considerable obscurity, so that not even the time of its discovery, nor the name of the discoverer, can be fixed on with any degree of certainty; but as, in its most simple form, the microscope consisted of little or nothing else than the magnifying power or lens, which must of necessity have been made of glass or some other transparent and highly refracting material, it is evident that its invention may be referred to a period anterior to the Christian æra. Aristophanes, who lived five centuries before Christ, speaks in his *Clouds* of a burning sphere. Seneca, who was born during the first year of the Christian æra, and died A.D. 65, writes that small and indistinct objects become larger and more distinct in form when seen through a globe of glass filled with water.* Pliny, who died in A.D. 79,

* "Litteræ quamvis minutæ et obscuræ, per vitream pilam aquâ plenam, majores clarioresque cernuntur." Nat. Quæst, lib. i., cap. 7.

mentions the burning property of lenses made of glass. Ptolemy, the celebrated astronomer of Alexandria, who flourished in the latter part of the first century, was evidently cognizant of the existence of magnifying glasses, and makes use of the word refraction in his work on optics. The testimony of these ancient writers, however, is only important as proving the existence of the microscope in its most simple and rudimentary form, viz., as an instrument composed of a single magnifying glass or sphere, whose chief application appears to have been that of concentrating the heating power of the sun's rays. To our countryman, Roger Bacon, who was born at the commencement of the third century, is attributed the invention of the telescope, the camera obscura, the reading glass, and gunpowder, and, by some, the discovery of the microscope; as he speaks, in his *Opus Majus*, of principles applicable to it, and Record, in his work entitled *Chemin de la Science*, published in 1551, relates that Bacon, whilst at Oxford, made a glass which exhibited such curious things, that its effect was generally attributed to some diabolical power. It is, however, certain that the simple microscope, if we apply this term to every instrument used for magnifying objects, first consisted of a sphere of glass or of a globe, of the same material, filled with water, these, no doubt, were soon superseded by lenses of a bi-convex figure, for, according to Dr. Francis Redi, these latter were in use early in the fourth century. Some hundreds of years were suffered to elapse before the microscope was again noticed, and then we read of it in its improved or compound form, as being supplied with two or more magnifying powers. Several authors, especially Huyghens, assign the invention of the compound microscope to Cornelius Drebbel, a Dutchman, in the year 1621, whilst Fontana, a Neapolitan, claims the discovery for himself in 1618. According to Borellus, it was invented by Zacharias Jansen or Zansz, or his father Hans Zansz, spectacle-makers at Middleburg, in Holland, about the year 1590. They are said to have presented the first microscope to Charles Albert, Archduke of Austria. "One of their microscopes," says Sir D. Brewster, in his *Treatise*

on *Microscopes*, page 2, "which they presented to Prince Maurice, was in the year 1617 in the possession of Cornelius Drebbel of Alkmaar, who then resided in London as mathematician to King James I., in which place he made microscopes, and passed them off as being of his own invention." These instruments were said to be six feet in length, and consisted of a tube of gilt copper, one inch in diameter, supported by thin brass pillars, in the shape of dolphins, on a base of ebony, which was adapted to hold the object to be examined; nothing, however, is known of their internal construction, they were, probably, nothing more than telescopes converted into compound microscopes, and there is no doubt but that they were similar to the one which *Æpinus* has described in a letter addressed to the Academy of Sciences of St. Petersburg. We are also told by *Viviani*, an Italian mathematician, in his *Life of Galileo*, "that this great man was led to the discovery of the microscope from that of the telescope, and that, in 1612, he sent one to Sigismund, King of Poland;" he adds, "that this philosopher worked twenty years at his apparatus in order to perfect it. But, notwithstanding all the above conflicting statements, the credit of the invention of the compound microscope is given (in this country at least) to *Zacharias Jansen*, in 1590."

Leaving then the region of uncertainty, let us now direct our attention to matters of a more tangible nature. With the foundation of the Royal Society, in 1660, may be said to have commenced a new æra in optical science, for not only do we now find new microscopes described, but the early volumes of the transactions literally teem with improvements in the construction of these instruments, and with discoveries made through their medium. One of the first contributors appears to have been the celebrated *Robert Hooke*, who, as early as the year 1667, published a work on some physiological descriptions of minute bodies made by magnifying glasses, entitled *Micrographia*, which may be fairly styled one of the wonders of the day; it is illustrated with 38 plates, and was ordered for publication November 23rd, 1664, but did not appear until three years afterwards.

The microscope used by Hooke was a compound one with three lenses, and is shown at fig. 1, and also in the sixth figure of the first plate of his work, in which figure it will be perceived that he likewise represents a method of illuminating opaque objects, which is even practised at the present day, the plan being to place a globe of glass filled with salt water or brine immediately in front of the lamp, the pencil of

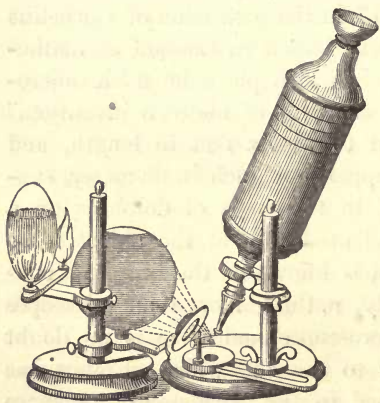

Fig. 1.

of the lamp, the pencil of rays from the globe are received by a small planoconvex lens, placed with its convex side nearest the globe, which condenses them upon the object. Hooke also informs us of an accurate method of finding the magnifying power of a compound microscope, than which a better plan has not been suggested in modern times, and as it would be difficult to make his description shorter or more intelligible than it is, I shall here transcribe his own words:—"Having rectified the microscope to see the desired object through it very distinctly, at the same time that I look upon the object through the glass with one eye, I look upon other objects at the same distance with my other bare eye; by which means I am able, by the help of a ruler divided into inches and small parts, and laid on the pedestal of the microscope, to cast, as it were, the magnified appearance of the object upon the ruler, and thereby exactly to measure the diameter it appears of through the glass, which being compared with the diameter it appears of to the naked eye, will easily afford the quantity of its magnifying." To Hooke also belongs the merit of having first made globule lenses of high power, an invention which Hartsoeker has also claimed; but if the dates of the works of these respective authors be consulted, it will be seen that the *Micrographia* of Hooke was published in the same year that Hartsoeker

was born. Hooke describes exceedingly well the process of making globule lenses, which is as follows:—"If you take a clear piece of Venice glass, and, in a lamp, draw it out into fine threads, and then holding the ends of these threads in the flame, until they melt, they will run into a small round globule or drop, which will hang to the end of the thread; having made a number of these, they are all to be stuck upon the end of a stick with a little sealing-wax, with the threads standing uppermost, these ends are to be ground off first on a whetstone and then polished on a metal plate with tripoli. The lenses thus finished, if placed against a small hole made in a thin piece of metal, and fixed there with wax, will both magnify and make some objects more distinct than any of the great microscopes can do."

The optical part of the microscope of Hooke consisted of a small object-glass, a field-glass, and an eye-glass; when he wished to examine the parts of an object more accurately, he removed the middle or field-glass, and by that means he states he obtained more light and better definition. The compound body was of the shape represented by fig. 1, and when shut up was seven inches in length, and three inches in diameter, but was capable of being drawn out like a telescope, it being supplied with four tubes or slides; it was also capable of being inclined at any angle by means of a ball and socket joint, as represented by fig. 1. Coeval with Hooke were Eustachio Divini, of Rome, and S. Campani, of Bologna, the former of whom, in the year 1668, published, in the *Philosophical Transactions*, an account of his microscope, which consisted of an object-glass and field-glass, like that of Hooke, but, instead of a double convex eye-glass, he substituted two planoconvex lenses, which touched each other in the middle of their convex surfaces; by this arrangement a flat field of view was obtained, at the same time with a considerable amount of magnifying power. It is said,* that the compound body of this instrument, when shut up, was sixteen inches long, and as large in circumference as a man's thigh, and that the eye-glass was equal in size to the palm of the hand; its

* *Chevalier des Microscopes et de leur usage*, p. 15.

power was increased by draw tubes from 40 to 140 times. The latter, or S. Campani, of Bologna, was also a maker of telescopes and microscopes, and a successful rival of the former, his instrument was somewhat similar to that made by Divini, being on the principle of an inverted telescope, Campani's

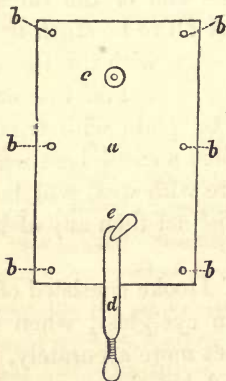

Fig. 2.

lenses are said to have been worked on a turn-tool, and not moulded. In 1672 we find that S. P. Salvetti made microscopes in imitation of those of Divini and Campani, but which were found to far exceed those of the above-mentioned artists in their magnifying and defining powers; but we are not told in what points of construction these instruments differed from those of his predecessors.

In the year 1673, the name of the immortal Leeuwenhoek first appears in the *Philosophical Transactions* of this country, as a discoverer of numerous wonders by aid of the microscope; his instruments, which were composed of single lenses, are said to have been greatly superior to all that had been previously made. According to Baker, they were also remarkable for their simplicity, each one consisting of a single lens set between two plates of silver, perforated with a small hole, with a moveable pin before it, to place the object on and adjust it to the eye of the beholder. "It has been stated by many authors," says Baker, (*On Microscopes*, vol. ii.) "that the magnifiers used by Leeuwenhoek were globules or spheres of glass, like those invented by Hooke, but such is not the case; he assures us that in the cabinet of the twenty-six micro-

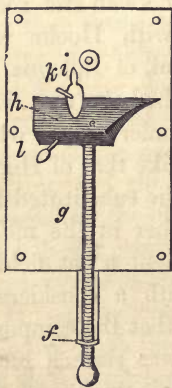

Fig. 3.

scopes, left by that famous man at his death to the Royal Society as a legacy, each instrument has a double convex lens, and not a sphere or globule."

An account of these microscopes was drawn up by Baker, in 1740, and published in the *Philosophical Transactions* for that year. Fig. 2 represents a front view of the instrument, and fig. 3 a back view, both being of the exact size of the original: *a* fig. 2 represents a flat plate of silver, which is rivetted to fig. 3 by rivets *b b b*; between these plates a small double convex lens is let into a socket, and a hole drilled in each plate for the eye to look through the lens at *c*, fig. 2; a limb of silver *d* is fastened to the plate *a* by a screw *e*, this has another piece of silver joined to it at right angles *f*, fig. 3, through this a long fine-threaded screw *g* runs, which turns in and raises or lowers the stage *h*, whereon is fastened a pin *i*, for the object to be attached to, this pin can be turned about by the little handle *k*, and the stage itself is adjusted to or from the lens by the screw *l*, which passes through the stage in a horizontal position, and when the screw is turned, the stage is forced from or brought nearer to the lens at *c*.

"All the parts of these microscopes," says Baker, "are of silver, and fashioned by Mr. Leeuwenhoek's own hand, and the glasses, which are excellent, were all ground and set by himself, each instrument being devoted to one or two objects only, and could be applied to nothing else. This method induced him to make a microscope with a glass adapted to almost every object, till he had got some hundreds of them. The highest magnifying power was 160 diameters, and the lowest 40.

In the year 1698, Philip Bonnani, in his work entitled *Observationes circa viventia, quæ in Rebus non viventibus reperiuntur*, describes a compound microscope in use by him. This microscope, which is represented by fig. 4, was placed on a stand in the horizontal position, and was provided with a stage for the objects; and, with a coarse and fine adjustment to the compound body, the former was obtained by means of a rack and pinion, which moved the entire frame-work, supporting the compound body, whilst the latter was effected by a screw in the end of the body

itself near to the object glass; and to steady the opposite end of the body, a triangular support was provided, on which the

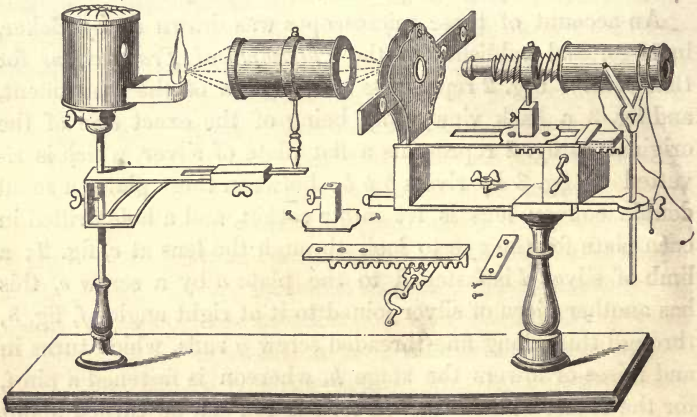

Fig. 4.

body was readily turned. In order to make the light of a lamp, or even daylight, more efficient, this instrument was supplied with a short tube, in which were two double convex lenses, as in a magic lantern, which served to condense the light upon the object.

From the time of Bonnani until the commencement of the eighteenth century, little was done towards the improvement of the microscope. During this interval, a work entitled *Oculus Artificialis Teledioptricus, &c.*, was published at Nuremberg, in 1702, by Jean Zahn, in which were contained numerous curious aphorisms, and a description of many compound microscopes, and, amongst others, two binocular ones, and also a figure of the microscope of Francis Grindelius, which is represented by fig. 5. It will be seen that this instrument



Fig. 5.

was used for opaque objects, and that its optical part consisted of six planoconvex lenses, but of its size we have no record.

About this time, the end of the 17th century, Sir Isaac Newton was in the zenith of his glory; having discovered, in 1672, the theory of light and colours, he was led to the improvement of the telescope, by substituting mirrors for lenses, and he commences his memorable paper in the *Philosophical Transactions* with these words:—"When I had found that light consists of rays differently refrangible, I left off my glass works, for I saw that the perfection of telescopes was hitherto limited not so much for want of glasses truly figured, as because that light itself is a heterogeneous mixture of differently refrangible rays. Having constructed a telescope on the reflecting principle, Newton was soon led to apply the same principles to the microscope, and we find that in the year 1672 he discovered the first compound reflecting microscope, which has since been so greatly improved by Amici, Tulley, Cuthbert, and Dr. Goring. Newton also suggested that the compound refracting microscope would be greatly improved "if the object to be viewed were illuminated in a darkened room by light of any convenient colour not too much compounded;" in fact, monochromatic light.

About this period, 1696, we find that Mr. Stephen Gray, of the Charterhouse (*Philosophical Transactions*, No. 221, p. 280), suggests that globule lenses should be formed of small pieces of glass melted into a globule on charcoal by means of a blowpipe; but finding that he could not always succeed, and that on the side on which they rested on the charcoal they were more or less flattened or opaque, he was led to the construction of his water microscope, which was nothing more than a drop of that fluid lifted up with a pin and deposited in a small hole in a piece of brass. The drop retained nearly a spherical form, and showed objects with some degree of distinctness.

He subsequently contrived the apparatus represented by fig. 6, to be used as a water microscope: *a b* is called the frame of the microscope, and was made of brass one-sixteenth of an inch thick; at *a* is a small hole one-thirtieth of an inch in diameter,

which contains the water, which can be dropped into it by a pin or large needle, and there forms a double convex lens of water :

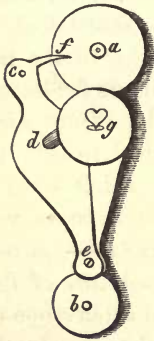

Fig. 6.

Mr. Stephen Gray was also the inventor of a simple reflecting microscope, represented by fig. 7. A represents a brass ring,

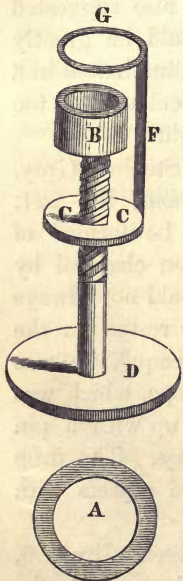

Fig. 7.

c d e, is another piece of brass, well hammered, so as to be springy, and called the object supporter; it is attached to the plate *a b*, by the screw *e*; it has a point for opaque objects at *f*, and a hole for fluids at *c*, both of which can be brought opposite to the lens *a*, and can be made to approach or recede from the lens by turning the screw *g* in the round plate. This screw is attached to the object supporter *c, d, e*, and passes through it to the plate *a, b*, against which it works. The supporter, being made springy, obeys readily the turns of the screw *g*.

one-thirtieth of an inch thick, whose inner diameter is about two-fifths of an inch. Having dissolved a globule of quicksilver in one part nitric acid and ten parts water, he rubbed with it the inner surface of the ring, which became silvered: having wiped it dry, he put a drop of quicksilver within it, which, when pressed with the finger, adhered to the ring, and formed a convex speculum. When the ring was taken up carefully and laid on the margin of the cylinder *B*, the mercury sank down and formed a concave reflecting speculum. The cylinder *B* is supported by a pillar, which is attached to the foot *D*, *C C, F, G*, represents a stage, which is capable of being raised or depressed by the screw on the pillar. The object is placed on the ring *G*, and is adjusted to the focus of the speculum by the abovementioned screw.

This ingenious gentleman also in May, 1697, suggested the

making of lenses of water let fall on pieces of plane glass, which form themselves into planoconvex lenses: he found that they magnified greatly, but as the fluidity of the water obliged him to keep the glass horizontal, he was led to try isinglass dissolved in hot water, whereby the drops, when cold, although less transparent than the pure water, nevertheless allowed of these lenses being used in any position, a plan which many years after was followed up and greatly improved by Sir David Brewster, who used minute drops of varnish or other viscid fluids placed on the thin pieces of flat glass. When the lens so formed was required to be very convex, the glass was held so that the drop was downward; but when less convex, then the drop was allowed to dry with the plate of glass downwards.

In the year 1702, we find in the *Philosophical Transactions* a description of the pocket microscope of Mr. J. Wilson, who, following the opinion of Hooke, that single magnifying glasses, when they can be used, are preferable to microscopes

composed of two or more magnifying glasses, was led to the construction of this instrument, which, from its frequent mention by Baker and other authors, appears to have had a far-famed celebrity, and, indeed, many specimens of it are still to be met with; one of the earliest forms of this instrument is represented by fig. 8. The body A A A A, which was made either of ivory, brass, or silver, was of a cylindrical figure, and about two inches in length, and one inch in diameter; into the lower end the magnifiers are screwed,

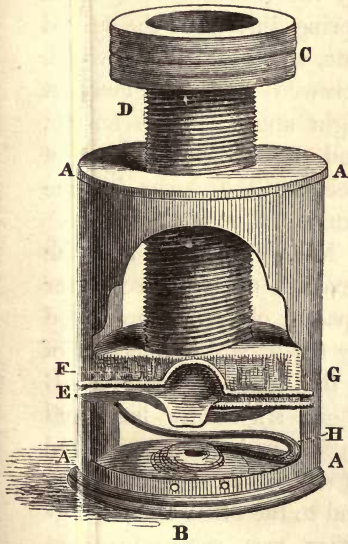

Fig. 8.

whilst into the upper screws, a piece of tube D, having

at the end C a convex glass, and on its outside a male screw. Three thin plates of brass E are made to slide easily in the inside of the body to form the stage, one of these plates F is bent semi-circularly in the middle, for the reception of a tube of glass, for viewing the circulation of the blood in small fish, whilst the other two are flat, and between these last all the object sliders are introduced; between the stage and that end of the body into which the magnifier screws is a bent spring of wire H, which answers the purposes of keeping the objects firmly between the plates of the stage, and also of pressing the stage firmly against the screw-tube. The magnifiers supplied with this microscope were eight in number, and the objects were adjusted to the focus of them by the screw-tube D, for which purpose the screw was made of nearly the same length as the body. This instrument was held in the hand in such a position that the direct light from a candle or lamp may pass directly into the condensing glass; and it was subsequently much improved upon

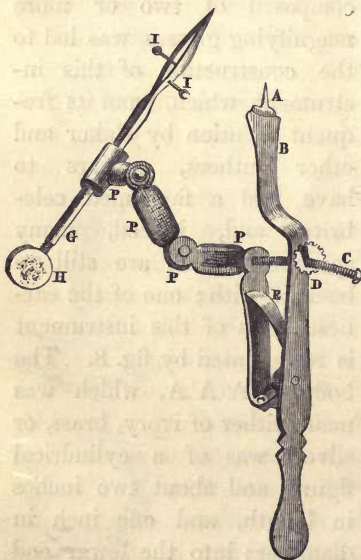

Fig. 9.

by the addition of a spiral spring, instead of the curved one, and by a handle which screwed into the body at right angles to its length, and served the purpose of keeping the body in the horizontal position.

Mr. Wilson was also the inventor of a microscope for opaque objects, represented by fig. 9, which consisted of a thin piece of flat brass B about six inches long and half-an-inch wide, one end of which served as a handle, and to the other A the magnifier was screwed; connected with the middle of

this piece of brass by a hinge was a jointed arm PP,

which carried at its free extremity a sliding wire G, to one end of which was attached a pair of forceps I I, and to the other a small disc of ivory H, blackened on one side and white on the other; the arm was capable of being adjusted to or from the lens by means of a screw C, having a nut with a milled head D, the spring E served to keep the lens holder A B in contact with the nut; this form of instrument is in use at the present day, and a modification of it was adopted by the celebrated Lieberkuhn about forty years afterwards.

The wonderful discoveries made by Leeuwenhoek by the single microscope gave to this kind of instrument an universal reputation, and we find, accordingly, that the compound

form was laid aside for a time, and the pocket microscope of Mr. Wilson was in great demand. Upwards of thirty years were suffered to elapse before we again find (in this country, at least) any step towards the improvement of this instrument; but the compound microscope, then in use, was the contrivance of Mr. John Marshall, and, from its unwieldy nature, was very little employed. It was, however, the first of the compound kind which

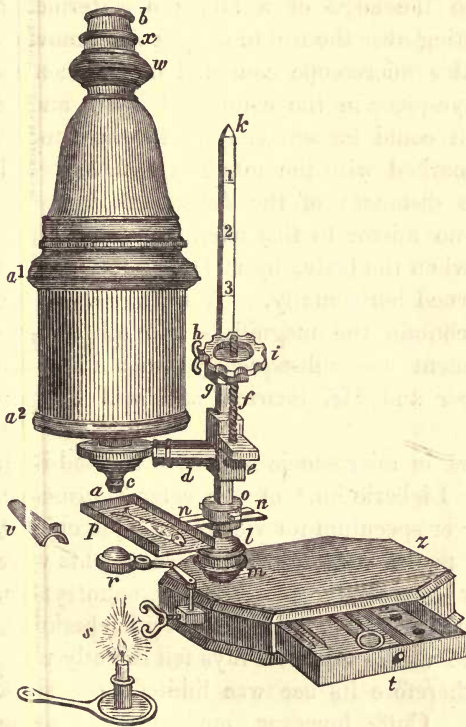

Fig. 10.

was made for sale in this country, and is represented by

fig. 10. It consists of an octagonal base of wood *z*, which supports a square pillar of brass *lk*, having a ball and socket joint at *m*. On the pillar *lk* an arm *d*, carrying the compound body *a'a'*, is made to slide up and down, and above it another smaller arm *g*, which has a screw for tightening it, at *h*; *f* is a long screw which is attached to the arm *d* which carries the compound body, and when the arm *g* is fixed by the screw *h*, the nut *i* will raise or depress the compound body; *p* is the stage, which is fixed to the pillar by the arm *nn* and the nut *o*; and a fish is laid on the stage for examination; *r* is a convex lens, for concentrating on the stage the rays of light from the candle *s*, which was placed on a stool, or on the ground, whilst the microscope stood on the edge of a table; *v* is termed a leaden coffin, for putting over the fish to keep it from moving. The optical part of this microscope consisted of two convex lenses, forming the eye-piece in the compound body, and of six magnifiers, which could be screwed on to the tube *c*. The pillar *lk* was marked with the numbers 1, 2, 3, &c., to show the respective distances of the magnifiers from the object. There was no mirror to this microscope, but direct light could be used when the body, by means of the ball and socket-joint, was turned horizontally. A drawer *t* in the stand *z* served to contain the magnifiers and other apparatus. This instrument was subsequently much improved upon by Mr. Culpeper and Mr. Scarlet, and will be presently described.

In 1738, a new æra in microscopic science presented itself in the discovery, by Lieberkuhn,* of the solar microscope, and of a concave silver speculum for viewing opaque objects, which still bears his name, both of which instruments were subsequently greatly improved upon by our countryman, Mr. Cuff. The solar microscope, as invented by Lieberkuhn, could not be employed unless the sun's rays fell directly upon a condensing lens, therefore its use was limited to a short portion of the day. Cuff, however, applied a moveable mirror to it, and made it more available for general use.

* Dr. Nathaniel Lieberkuhn of Berlin.

Lieberkuhn himself exhibited his microscopes to some Fellows of the Royal Society of London in 1739.

The solar microscope, as improved by Mr. Cuff, for a length of time created great wonder and astonishment; it was principally used for the exhibition of animalcules, and the circulation of the blood in the newt, frog or eel; and was also recommended for getting the exact figure of objects on a large scale, the image being received upon a screen of paper, on which the outline was traced either with a pen or pencil; when the paper was sufficiently thin, the artist, standing behind the screen, was enabled to draw the image much better than when standing in front of it, and with this great advantage, that the shadow of the hand did not interfere with, or obstruct, any portion of the light.

But by far the most useful of Lieberkuhn's microscopes was the one for viewing opaque objects, by means of which

he made so many important discoveries in the minute structure of the mucous membrane of the alimentary canal, as to immortalize his name. The most simple form of this instrument is represented by fig. 11; it is not unlike the pocket instrument of Wilson, represented by fig. 9, and, like it, was held in the hand by the handle *p*; *a* is a flat piece of brass attached to the handle *p*, it supports the lens holder *i*, and through it passes the screw *b*, which is connected to the back-plate *c*; a spring *e* keeps the plates *a*, *c*, apart, and the nut *d* adjusts the lens to the focus of the object, either on *g* or *h*. But the chief point of merit in its construction consists in a concave speculum of silver *k* highly polished, to the centre of which the magnifying glass *l* is adapted; this being screwed into the ring *i*, and the object being fixed upon the point *g*, or held in the forceps *h*, the instrument is

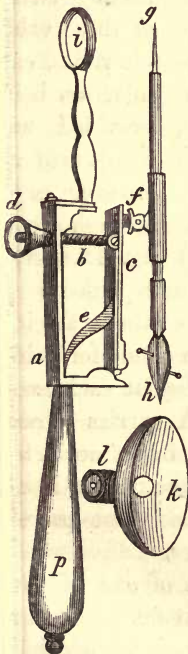

Fig. 11.

placed in such a position, that the light from the sun, or bright cloud, being received upon the speculum, the rays are concentrated upon it, and it becomes brightly illuminated, and is adjusted to the focus of the lens by turning the nut *d*; all loss of time in the screw being prevented by the spring *e*. The Lieberkuhn, is that part of the instrument

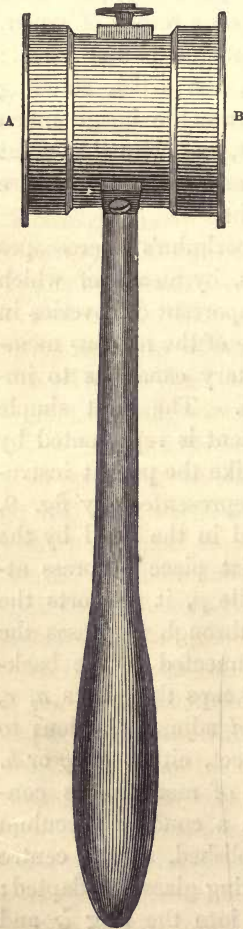

Fig. 12.

which is the most important, and is in general use even in the present day. Lieberkuhn was also celebrated for his beautiful injections of the minute tissues and organs of vertebrate animals; many specimens of which are still extant.

In the museum of the Royal College of Surgeons of England there is a small cabinet of two drawers, con-

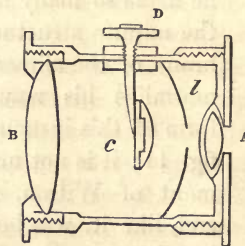

Fig. 13.

taining twelve of these valuable relics, each injection being provided with a separate microscope, of the form shown by fig. 12. A, B represents a piece of brass tube, about an inch long, and an inch in diameter, which is provided with a cap at each extremity, the one at A carries a small double convex lens of half an inch in focal length, whilst the one at B carries a condensing lens three-quarters of an inch in diameter.

A vertical section of one of these instruments is seen at fig. 13. A represents the magnifier, which is lodged in a cavity, formed partly by

the cap A and by the silver cup or speculum *l*. In front of the lens is the speculum *l*, which is a quarter of an inch thick at its edge, and whose focus is about half an inch, and in front of this there is a disc of metal *c* three-eighths in diameter, which is connected by a wire with the small knob D; upon this disc the injected portion is fastened, and is covered over with some kind of varnish which has dried of a hemispherical figure. Between this knob and the inside and outside of the tube there are two slips of thin brass, which act as springs to keep the wire and disc steady. When the knob is moved, the injected object is carried to or from the lens, so as to be in its focus, and to be seen distinctly, whilst the condensing lens B serves to concentrate the light on the speculum. To the lower part of the tube a handle of ebony, about three inches in length, is attached by a brass ferrule and two screws. The use of this instrument is obvious; it is held in the hand in such a position, that the rays of light, from a lamp or white cloud, may fall on the condenser B, and are by it concentrated on the speculum *l*, which again further condenses them on the object on the disc C, which object, when so illuminated, can readily be adjusted by the little knob D, so as to be in the focus of the small magnifier at A.

The injected preparations in these twelve microscopes, now nearly a century old, are remarkably beautiful, and the only injury which they have sustained, is that of the varnish, which, from age, has cracked in some places. Lieberkuhn's principal researches were confined to the minute structure of the mucous membrane of the alimentary canal; and for the investigation of these opaque parts, he is said to have invented the silver speculum which bears his name, although, from a description and figure in the works of Leeuwenhoek,* one would be inclined to suppose that that illustrious man was cognizant of its principles and use.

The microscope which Lieberkuhn used for the examination of the mucous membranes, and the circulation of the blood and chyle in the mesentery of small animals, is repre-

* Vol. ii. p. 280, Works by Hoole.

sented by figs. 14 and 15, and will be found to be accurately described in a work entitled, *Dissertationes quatuor Johannis*

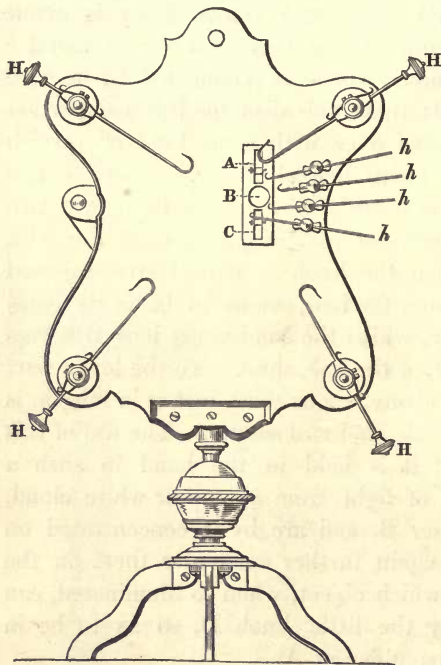

Fig. 14.

one end, and opposite to the three holes in the plate marked A B and C are four smaller hooks *h h*, the former are for the purpose of fixing into the legs of any small animal, the circulation in whose mesentery, either of the blood or of the chyle, is about to be examined; and the latter, or the small hooks, are used for bringing successive portions of the mesentery opposite the holes.

The part of the microscope which carries the magnifying powers is attached to the plate by pegs; it consists of a thin plate of brass 1, fig. 15, to which plate is attached another one 2 by a rivet 3, this last plate is a little curved, and is also made elastic; in its centre is a screw 4, and at its free end is a hole 5, into which the magnifier screws; a section of this part of the microscope is seen in fig. 16, where A re-

N. Lieberkuhn, collected and revised by John Sheldon, surgeon, 1782. It consists of a plate of copper or brass, about one-eighth of an inch thick, and twelve inches long by eight broad, and fashioned into the shape represented by the figures. It is supported, in a vertical position, on a tripod stand, the back of the instrument is represented by fig. 14, and the front by 15. At each corner there is a small sliding wire H H, with a hook at

presents the connection of the two plates by a rivet, and B the bend in the top or lens holder, C the screw for adjustment, and D the hole into which the lens E screws. The

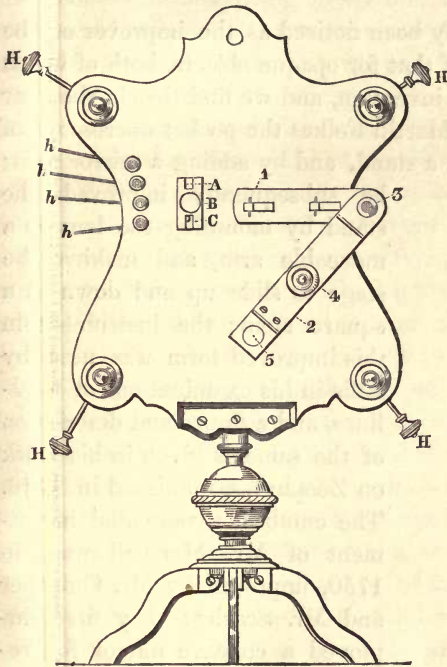

Fig. 15.

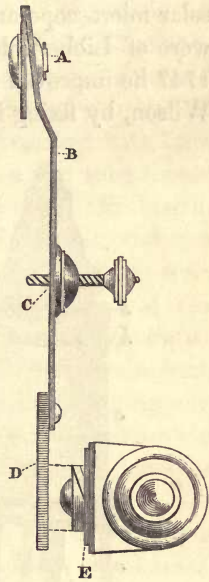

Fig. 16.

animal being properly secured by the large hooks, and the portion of it to be examined being brought before the hole B by the small hooks, the instrument is so placed, that the light from a window or lamp may pass through the hole, the arm provided with the lens being brought opposite the hole, and over the piece of brass 1 the lens can be adjusted to or from the object by the screw 4, and the plate being curved and elastic, will always obey the turns of the screw. This form of instrument was not constructed for sale in this country, as far as I can learn, and was never improved upon like the solar, or the microscope for opaque objects. It, no doubt, was entirely superseded by others more generally

useful; and at this time, 1740, we find many makers of eminence residing in this metropolis, amongst whom, the names of Cuff, Benjamin Martin, Adams, and Marshall require especial notice.

Mr. Cuff has already been noticed as the improver of the solar microscope and of that for opaque objects, both of which were of Lieberkuhn's invention, and we find that in the year 1747 he improved for Martin Folkes the pocket microscope of Wilson, by fixing it to a stand, and by adding a mirror to it;

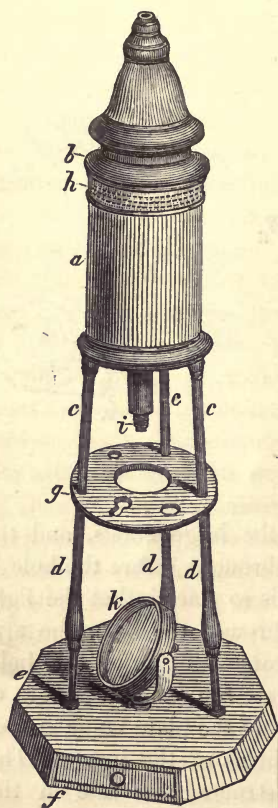

Fig. 17.

he subsequently improved the stand by mounting the lens on a moveable arm, and making the stage to slide up and down on a square stem; the instrument in this improved form was used by Ellis in his examinations of coral-lines, and a figure and description of the same is given in his work on Zoophytes, published in 1756. The cumbrous compound instrument of Mr. Marshall was, in 1750, improved by Mr. Culpeper and Mr. Scarlet: they first employed a concave mirror for reflecting the light through the object and the compound body. Their instrument is represented by fig. 17, it was composed of two tubes *ab*, either of wood or paper, sliding one within the other; to the tube *a* were attached the pillars *cd, cd*, which rose from the base *e*, and supported the round stage *g*, in which was a large circular hole for a spring object holder to be fixed, and some smaller holes for the reception of the forceps, small condensing lens and fish-pan. To the inner

tube *b* all the optical apparatus was adapted, the magnifiers, which were from four to six in number, being screwed to the end of the small tube *i*, and the eye-piece, which consisted of two convex lenses, being fitted into the wooden top of the compound body *b*. A concave mirror *k* was used for reflecting the light, and a drawer *f* in the base *e* served to contain all the magnifiers and other parts of the apparatus. The only adjustment for focus with which this microscope was provided, was that accomplished by sliding the tube *b* up and down in the outer tube *a*, the tube *b* being marked with lines at *h*, to denote the distances through which the tube should be moved for the different magnifying powers. This instrument was subsequently much improved in shape, and was made either of brass or silver, and a rack and pinion were used for the adjustment. It was in great demand at one time, and, with its pyramidal case and drawer with apparatus, may even now be frequently seen for sale in pawnbroker's shops. This microscope was styled the double reflecting one, and was the first instrument to which the concave mirror was applied for illuminating transparent objects, the mode of mounting which is similar to that now adopted.

In the year 1744, we are told by Baker,*—"That the microscopes of Hooke and Marshall having been reduced to a manageable size, improved in their structure, and supplied with an easy way of enlightening objects by a speculum underneath, and, in many other respects, rendered agreeable to the *curious*, by Mr. Culpeper and Mr. Scarlet. Some further alterations were, however, wanted to make this instrument of more general use, as I fully experienced in 1743, when examining daily the configurations of saline substances, the legs were continual impediments to my turning about the slips of glass, besides pulling the body of the instrument up and down, was likewise subject to jerks, which caused a difficulty in fixing it exactly at the focus: there was also no good contrivance for viewing opaque objects. Complaining of these inconveniences, Mr. Cuff, the optician, applied his thoughts to fashion a microscope in another manner, leaving the stage entirely free and

* Vol. ii., *Employment for the Microscope*, p. 422.

open by taking away the legs, applying a fine threaded screw to regulate and adjust its motions, and adding a concave speculum for objects that are opaque." This microscope was made entirely of brass, and was fastened to the top of a box, by a scroll or bracket, from which rose two flattened pillars, one of which, carrying a horizontal arm, was made to slide up and down against the other, this arm carried the compound body, the coarse adjustment of the body was effected by this movement, but the fine by a screw two inches in length, which was fixed to the back of one of the pillars, and when its nut was secured by a screw, which clamped the sliding pillar, then the body could be moved slowly up and down. The stage, which was somewhat of the shape of a cross, had several holes in it, for the reception of the condensing lens, forceps, and fish-pan. The lower part of the compound body was cylindrical for the space of two or more inches, and marked with numbers corresponding to those of the lenses; upon this a Lieberkuhn, with a long tube, was made to slide, and when set to the figures there marked, an object placed on the stage would be in the focus of the speculum. In the year 1747, Mr. Cuff invented a micrometer for this instrument, it was made of a lattice of fine silver wires, distant from each other one-fiftieth part of an inch, intersecting at right angles, and so placed in the focus of the eye-glass as to divide the whole visible area of the microscope into squares, whose sides are each one-fiftieth of an inch. The microscope of Benjamin Martin, described in a work published at Reading in 1746, was of the compound form, and adapted for being carried in the pocket; it was of a cylindrical shape, like the body of Culpeper's, and, like it, the adjustment was made by sliding one tube within the other, the mirror was placed in the bottom of the tube in an inclined position, and was not capable of being moved. It was also supplied with a screw micrometer of a peculiar construction, which had, on the outside of the body, a dial-plate and hand resembling the face of a watch. To this ingenious optician we are indebted for the invention of the hand magnifier, with one or more lenses, which has undergone little or no change since his time. We

are told that Benjamin Martin greatly improved the microscope of Cuff before described, by the addition of a joint, so that the compound body might be inclined to any angle, and also by the setting of all the lenses in a circular disc of brass, which was capable of being revolved in such a manner, that each lens in succession might be brought under the compound body; this did away with the necessity of screwing and unscrewing when the powers were required to be changed. The compound body could be removed from the lenses, and the lenses themselves then constituted it a single microscope, the arm which supported them was capable of being moved backwards and forwards by means of a rack and pinion, a plan now in use.

About this time, 1740, there lived in this metropolis a philosophical instrument maker of some eminence, named George Adams, who published, in 1746, a quarto work, entitled *Micrographia Illustrata; or, the Knowledge of the Microscope Explained*. In this work were contained a description of the nature, uses, and magnifying powers of microscopes in general, together with full directions how to prepare, apply, and examine, as well as preserve, all sorts of minute objects. This work was the first of the kind published in this country, and contributed not a little to the advancement of microscopic science. The microscopes made by Adams, were of two kinds, the single and the compound; their chief peculiarity consisted in the arrangement of the lenses, which were six in number, and were all set in a large plate of brass, capable of being turned upon the central pillar of the instrument, and each lens in succession could be brought underneath a hollowed plate or cup, which served as an eye-piece. For the coarse adjustment the plate was made to slide up and down the pillar, whilst for the fine a screw was used, which slowly raised or depressed that portion of the pillar to which the stage was attached. Besides these microscopes of his own invention, we find that he was in the habit of making those of Wilson, Lieberkuhn, and Culpeper, all of which are fully described in the work above-named.

We now approach a period, fertile both in the improve-

ments of the microscope, and in discoveries made by its agency; we have amongst the former, the results of the labours of Adams, Martin, Baker, and Dellebarre; and amongst the latter, the works of Trembley, Ellis, Baker, Adams, Hill, Swammerdam, Lyonet, Needham, and Withering. Every optician, says Adams,* now exercised his talents in improving (as he called it) the microscope; in other words, in varying its construction, and rendering it different from that sold by his neighbour. The principal object seemed to be only to subdivide it and make it lie in as small a compass as possible, by which means they not only rendered it complex and troublesome to manage, but lost sight also of the extensive field, great light, and other excellent properties of the more ancient instruments. In 1770, Dr. Hill published a treatise on the Construction of Timber, explained by the microscope, which pointed out the nature and office of its several parts, and the way of judging from the structure the uses to which they can be best applied. This work created a great sensation at the time, and revived the ardour for microscopic pursuits. Adams at this time invented a machine for cutting transverse sections of wood so thin, that they might readily be examined by the microscope. This instrument was subsequently improved on by Mr. Cumming, and with it such beautiful sections were made by Mr. Custance, that they stand unrivalled even at the present day. In 1771, a new edition of the *Micrographia Illustrata* of Adams appeared, in which he described a lucernal microscope of his own invention; this was subsequently improved by his son, George Adams, in 1774, and was made capable of exhibiting opaque as well as transparent objects. The solar microscope, too, at this time had been greatly improved by Benjamin Martin, and was made capable of showing on a screen a magnified image of the surfaces of opaque objects.

In 1787 the *Microscopical Essays* of the younger Adams were published, in which were described all the instruments at that time in use. Of the single form, we have Wilson's, shown at fig. 8; those of Ellis, and Lyonet; also that of Dr.

* *Microscopical Essays*, p. 19.

Withering, represented by fig. 18, which even now is manufactured for sale; it consists of three brass plates *a b c*, parallel with each other, to the upper and lower of which three stout wires *d e f* are rivetted; the middle plate *b*, which forms the stage, is made to slide up and down on these three wires. The upper plate *a* carries the lenses *i*, the lower one *c* the mirror. Into the stage a dissecting knife *h*, a pointed instrument *f*, and a pair of forceps *g*, are made to fit, and can be readily taken out for use by sliding the stage down

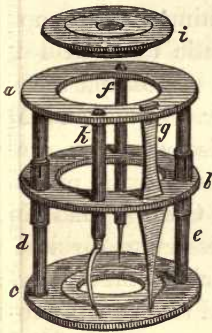

Fig. 18.

nearly to the mirror; this instrument was recommended by Dr. Withering, and was first described in his *Botanical Arrangements*, its chief merit being its simplicity.

The compound microscopes described by Adams, are merely modifications of that of his father, of Culpeper, of Cuff, and of Benjamin Martin. The first, or that of the elder Adams, was improved by the addition of a rack and pinion movement, and by having all the lenses set in a brass slider, so that they may be placed one after the other under the compound body. The second, or that of Culpeper, was made of brass, and was improved in its optical part. Cuff's compound instrument was much the same as that described at page 22; whilst that of Benjamin Martin was improved by Adams himself, and was made capable of receiving a single lens as well as a compound body, and was furnished with a cradle joint, by which the compound body could be inclined at any angle; the mirror was double, both plane and concave; the legs, for convenience of package, were made to slide one within the other. With the work of Adams, in 1787, we may close our history of the single and compound microscopes in their unachromatised state, the discoveries at this time were few and comparatively unimportant, and little or nothing more was exhibited by them than the objects contained in the ivory sliders, with which all the above described microscopes were supplied; and he who could

exhibit these objects well, was considered a proficient in the art. These instruments, as described by Adams, without any material alteration in the optical part, continued in use up to the time of the invention of the achromatic form, in 1824, when a new and most important era in microscopic science commenced with the improvement by Dr. Goring and Mr. Cuthbert in the reflecting microscope, discovered by Amici in 1815, and with the manufacture of lenses of the precious stones by Sir David Brewster, Dr. Goring, and Mr. Pritchard. At this period it will be necessary to divide our history into two parts. The first to include the improvements made in the single, and the second those in the compound microscope. In consequence of the great loss of light, and the presence of the prismatic halo which enveloped every object seen through the uncorrected compound microscope, the single microscope was generally used by all scientific investigators; but when high powers were wanted, the glass of which they were made being of such low refractive power, it became necessary to use lenses of very short foci, which were of very small diameters, and allowed only a small amount of light to enter the eye; to remedy these inconveniences, Sir David Brewster first suggested the value of using other materials of a more highly refracting nature for the construction of lenses; and he remarked,* “that no essential improvement could be expected in the single microscope, unless from the discovery of some transparent substance, which, like the diamond, combines a high refractive with a low dispersive power. Having experienced the greatest difficulty in getting a small diamond cut into a prism in London, he did not conceive it practicable to grind and polish a diamond lens; and, therefore, he did not put his opinion to the test of experiment, but he got two lenses, one made of ruby, the other of garnet, which he found to be greatly superior to any lenses that had previously been used.” Dr. Goring, in the summer of 1824, having directed the attention of Mr. Pritchard to certain passages in Sir David Brewster’s admirable *Treatise on New Philosophical*

* *Treatise on the Microscope*, p. 13.

Instruments respecting the value of the precious stones for single microscopes; and having seen their full force, it was agreed that they should undertake to grind a diamond into a magnifier. The first diamond operated on was a small brilliant, and it was proposed to give it the curves that in glass would produce a lens of a twentieth of an inch focus. "This stone, when nearly finished," says Mr. Pritchard, "fate decreed that I should lose,* but having proved the possibility of working lenses of adamant, I set about another, and selected a rose diamond, in order to form a planoconvex lens." After great labour and expense, this Mr. Pritchard accomplished, and, on the 1st of December, 1824, he states, "that he had the pleasure of first looking through a diamond microscope." Dr. Goring, who tried its performance on various objects, both as a single microscope and as an objective of a compound, was well satisfied with its superiority over other forms of lenses. But here Mr. Pritchard's labours did not end, he subsequently found that this stone had many flaws in it, which led him to abandon the idea of finishing it. Having been prevented from resuming his operations on this refractory material for about a year, Mr. Pritchard, in his third attempt, met with another unexpected defect; he found that some lenses, unlike the first, gave a double or triple image, instead of a single one, in consequence of some of their parts being either harder or softer than others. These defects were afterwards found to be due to polarisation. Mr. Pritchard having learnt how to decide whether a diamond is fit for a magnifier or not, subsequently succeeded in making two planoconvex lenses of adamant, whose structure was quite perfect for microscopic purposes. "One of these," he tells us, "of one-twentieth of an inch in focal length, is now in the possession of his Grace the Duke of Buckingham; the other, of one-thirtieth of an inch focus, is in his own hands."

"In consequence of the high refracting power of a diamond lens over that of glass, a lens of the former material may be at least one-third as thin as that of the latter, and if the focal

* Those who would wish to enter more in detail into this matter, I must refer to Pritchard's *Microscopic Cabinet*, p. 108.

length of both be equal, say," says Sir D. Brewster,* "one-eightieth of an inch, the magnifying power of the diamond lens will be 2133 diameters, whereas that of glass would be only 800." Mr. Pritchard, in later times, succeeded, with much less difficulty, in making lenses of other precious stones, viz., the sapphire, ruby, and garnet, all these substances, although coloured to a certain extent, nevertheless were not unfitted for magnifying powers; and Sir David Brewster, whose authority is indisputable in these matters, states:†—"That they all exhibit minute objects with admirable accuracy and precision, and that the colour of the garnet, which diminishes with its thickness, disappears almost wholly in very minute lenses." The durability of lenses made of the diamond and other precious stones, is, however, an exceedingly valuable property, but the vast expense incurred in their manufacture, and the great superiority of the compound instrument, as now constructed, will ever be a barrier to their introduction into general use.

The microscope, with a single lens, having been brought to the greatest state of perfection by the labours of Sir David Brewster, Dr. Goring, and Mr. Pritchard, we must here leave it and direct our attention to certain combinations of lenses termed doublets and triplets, by means of which microscopic science has been considerably advanced, and, with the exception of the achromatic compound microscope, no more important improvement in the optical part of the microscope has ever yet been accomplished. As long ago as the year 1668, a doublet was described in the *Philosophical Transactions*, as made by Eustachio Divini,‡ in which a large and flat field was obtained by placing two planoconvex lenses so as to touch each other in the middle of their convex surface. "This instrument," it is there stated, "hath this peculiar, that it shews the objects flat and not crooked, and although it takes in much, yet nevertheless magnifieth extraordinarily." In the year 1812, a periscopic doublet lens was proposed by Dr. Wollaston,|| which was composed of two planoconvex lenses

* *Treatise on the Microscope*, p. 21.

† *Op. Cit.*, p. 24.

‡ No. 42, p. 842.

|| *Philosophical Transactions*, 1812, p. 375.

ground to the same radius, and applied by their plane surfaces to a flat piece of metal, having an aperture of the same size as that which would be suitable for a lens of equal size but composed of one piece of glass; and the size of the aperture which, on experiment, was found always to give the best definition, was that about one-fifth part of the focal length in diameter. This form of doublet was subsequently improved on by Sir David Brewster, who, instead of using the flat piece of metal and two planoconvex lenses, employed two hemispherical lenses, cemented to the end of a tube of brass, and filled all the interspace with a fluid of the same refractive power as the glass. This led Sir David to the idea of the grooved sphere, which is nothing more than a spherical lens having a deep groove cut round it in a plane perpendicular to the axis of vision; a plan analogous to that of the Coddington lens. Experiments on doublets were now carried on by Sir John Herschell, Sir David Brewster, Mr. Coddington, and others, and we have various forms recommended for use by each of these gentlemen; by the former we have three, viz., the periscopic doublet, which consists of a double convex lens of the best form, but placed in its worst position (radii as 6 to 1) for the lens next the eye, and a planoconcave, whose focal length is to that of the other, as 2, 6 to 1, or as 13 to 5, placed in contact with its flatter surface, and having its concavity towards the object. The second consisted of the planoconvex doublet, which is made with two convex lenses of equal focal lengths, the convex sides being placed in contact, and the eye and object opposite the plane sides; and the third, the doublet of no aberration, which consists of a planoconvex lens, and a meniscus placed in such a manner, as that the convex sides of both were in contact.

This form of doublet Sir John proposes as the best for obtaining perfect distinctness in microscopical observations, and Mr. Pritchard states:—“That doublets of this form answer remarkably well, but their angle of aperture is small as compared with combinations of double achromatics.” But by far

* *Microscopic Cabinet*, p. 163.

the most important contribution to microscopical science at this period, was the microscopic doublet, the invention of Dr. Wollaston, which is described in the *Philosophical Transactions* for 1829,* and with the mode of illumination therein recommended, gave to the single microscope an importance and degree of usefulness which it had never yet received in this or any other country. The doublet of Wollaston consisted of two planoconvex lenses, having their focal lengths in the proportion of 1 to 3, and placed at such a distance from each other as was ascertained to be best by experiment. It is said that he was led to this invention by a knowledge of the construction of the achromatic Huyghean eye-piece, which, if reversed, would make a microscope; but impaired health caused him to communicate his paper to the Royal Society earlier than he at first intended, and his premature death deprived him of the satisfaction of ever witnessing the great improvement subsequently made in his doublet, by the introduction of a stop or diaphragm between the two lenses. The microscope stand, with which the doublet was used, was as simple and as elegant in its



Fig. 19.

construction as the doublet itself; and is shown in section, by figure 19, where A B represents a brass tube, about six inches long and an inch or more in diameter, capable of being screwed into the cover of a box or stand, by the screw D. At C a circular perforation is made for the purpose of admitting the light to the mirror E. Above the mirror at F is a diaphragm or stop, for cutting off the outer rays of light reflected from the mirror. At the upper end of the tube is a planoconvex lens of about three quarters of an inch focal length, set in a metal frame at G, with its plain side uppermost; its use being to bring the rays of light to a focus on an object placed across the top of tube at P, which acts as a stage. At I is fixed a small rack, upon which an arm H, carrying the doublet M N O, can be moved up

* *Philosophical Transactions*, 1829, p. 9.

or down by the pinion K, which is turned by the milled head L. The doublet, which has been before alluded to, consists of two planoconvex lenses, set each in a separate cell M N. The cell which carries the upper lens screws into that which carries the lower lens, so that the distance between the individual lenses may be regulated for perfect definition; when in use, the doublet is placed in a hole in the arm H. Since Wollaston's time, the stand has been much improved, it has been fitted up with an adjustable stage, and with fine and coarse adjustments, and otherwise much altered in appearance; but the one we have described is copied from his paper in the *Philosophical Transactions*. A modification of this form of instrument is at present in use, as an illuminator with many microscopes, both simple and compound, and will be again referred to in the chapter on "Illumination of Transparent Objects." "With this microscope," Dr. Wollaston says "that he was able to see distinctly the finest markings upon the scales of the *Lepisma* and *Podura*, and upon those of the gnat's wing." The doublet itself is, at the present time much employed, and is preferred by many to the compound microscope for the examination of such objects as are perfectly flat, and by reason of its portability its value is much enhanced. It is infinitely superior to a single lens, and is capable of transmitting a pencil of an angle of 35° to 50° without any sensible errors, and exhibits most of the test objects in a very beautiful manner.

The next great improvement in the single microscope, and the last we shall here notice, was effected by Mr. Holland in 1832, and described by him in the forty-ninth volume of the *Transactions of the Society of Arts*. It consists, as shewn in fig. 20, of three planoconvex lenses *abc*, the first two *ab* being placed close together, and the diaphragm or stop between them and the third lens *c*. "The first bending," says Mr. Ross,* "being effected by two lenses instead of one, is accompanied by smaller aberrations, which are, therefore, more completely balanced or corrected at the

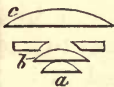

Fig. 20.

* *Penny Cyclopædia*, Art., Microscope.

second bending, in the opposite direction, by the third lens." This combination, though called by Mr. Holland a triplet, is essentially a doublet, in which the anterior lens is divided into two, and is capable of transmitting a pencil of 65° . Here we must take our leave of the history of the single microscope, and commence that of the achromatic compound instrument.

Notwithstanding the great improvements which had taken place in the compound microscope during a period of nearly two centuries, we find, says Mr. Ross,* that it was "a comparatively feeble and inefficient instrument, owing to the increase in the chromatic and spherical aberrations occasioned by the great distance through which the light had to pass. The image formed by the object-glass was not a simple one, but made up of an infinite number of variously coloured and variously sized images. Those nearest the object-glass would be blue, and those nearest the eye-glass would be red. The effect of this being the production of so much confusion, that the instrument was reduced to a mere toy, although these errors were diminished to the utmost possible extent by limiting the aperture of the object-glass, and thus restricting the angle of the pencil of light from each point of the object. But this proceeding made the picture so obscure, that, on the whole, the best compound instruments were inferior to the simple microscopes having a single lens, with which, indeed, almost all the more important observations of the preceding century were made." The compound microscope, in its chromatic condition, having been found to be incapable of further advancing in a right way scientific research, many artists of eminence applied themselves to the work of improvement, and we are told that achromatism was discovered in 1729 by a private gentleman in Essex, named Chester More Hall, who, in 1733, constructed and applied to a telescope an achromatic object-glass, having been led to its discovery by the study of the human eye, and by finding that two kinds of glasses combined, refracted light without decomposing it. Two of his achromatic telescopes were for a long

* *Op. Cit.*, p. 6.

time in the hands of persons who were not aware of their full value, and Mr. Hall himself paid the debt of nature without revealing the secret of their construction.

In 1747 we are told that Euler was led by his experiments to the construction of achromatic object glasses, a problem which for a long time had agitated the learned in England, Holland, Italy, and France; and in 1774 he proposed the application of an achromatic combination for the object glasses of microscopes. Our countryman, Dollond, "on the faith of Sir Isaac Newton's conclusions, zealously denied the possibility of doing what Euler proposed, but, nevertheless, commenced a series of experiments, beginning with that which had led Sir Isaac Newton to his unfavourable opinions, and which ended in accomplishing all that Euler had declared and Newton had hoped to be possible. These experiments, which included the spherical as well as the chromatic correction, were completed in the year 1757, and the glory of achieving this most valuable result is in no respect lessened by the fact, of which there is now no doubt, that a chromatic correction had been, to some extent, produced in the year 1733, by Mr. Chester More Hall."* Although Dollond constructed many achromatic telescopes, he did not apply the same principle to microscopes; but those which he sold were only modifications of the compound instrument of Cuff. Chevalier tells us † that there exists a very rare work, published at St. Petersburg in 1774, under the following title:—*Detailed instruction for carrying lenses of all different kinds to a greater degree of perfection, with the description of a microscope which may pass for the most perfect of its kind, taken from the dioptric theory of Leonard Euler, and made comprehensible to workmen by Nicholas Fuss.* It contains a description of the object-glass of the microscope, of which the following is the substance:—"The object-glass will be composed of three glasses; the first and third of which will be of crown-glass, and the second of flint. The focal distance will be half-an-inch, and the aperture of

* A. Ross. *Practical Illustrations of the Achromatic Telescope*, Part I., p. 11.

† *Op Cit.*, p. 86.

the lens one-eighth of an inch. The least thickness possible should be given to the glass composing the lens; the two lenses of crown glass will be bi-convex, and the middle one bi-concave, &c.

In 1784, *Æpinus* made many fruitless trials to achromatize the microscope, and, although he was successful to a certain extent in destroying colour, he diminished rather than increased the magnifying power of the instrument, and he made it, says *Adams*, rather more like “a microscopic telescope than a microscope.” A blank now occurs in the pages of microscopic history, from 1784 until 1800, and the microscopes in use in those days were more remarkable for the improvement in the mechanical construction of their stages and adjustments, than for that of the optical part; “and at this period,” says *Chevalier*, “it is to be remarked, with a sentiment of regret, that England was more laborious than France, and appeared to have the monopoly of the manufacture of the best instruments.”*

From the year 1800 to 1810, we are told by *Chevalier* that experiments were carried on by *M. Charles*, of the Institute, to achromatize small lenses; but the numerous imperfections of these lenses were such, as to render their application to the microscope completely impossible, as they were not so arranged as to be cemented or superposed, and their centering and curves, so full of imperfections, rendered them unfit for microscopic purposes.

In the year 1812, a very simple method was employed by *Sir David Brewster*† to render both single and compound microscopes achromatic, which was as follows:—Starting with the principle that all objects, however delicate, are best seen when immersed in fluid, he placed an object on a piece of glass, and put above it a drop of some kind of oil, having a greater dispersive power than the single or concave lens, which formed the object-glass of the microscope. The lens was then made to touch the fluid, so that the surface of the fluid was, as it were, formed into a concave lens, and if the

* *Op Cit.*, p. 85

† *Treatise on the Microscope*, p. 73, *et seq.*

radius of the outward surface was such as to correct the dispersion, we should have a perfect achromatic microscope, both simple and compound. This method, however ingenious, was attended with considerable inconvenience, and our eminent and time-honoured philosopher was led to the construction of a permanent achromatic object-glass, by placing some butter of antimony between a meniscus and a planoconvex lens of crown-glass, the antimony was retained between the glasses by capillary attraction, and could be removed as often as its properties were deranged.

About this period, 1812, we find that numerous experiments were carried on by Professor Amici, of Modena, to improve the achromatic object-glass, and during his investigations he invented a reflecting microscope, far superior to those of Newton, Baker, or Smith, which had been made as early as the year 1738, and had been abandoned for many years; this discovery, which so far excelled any microscope previously made, induced Amici, in 1815, to lay aside his experiments on the refracting instrument for a considerable period. An account of this microscope having soon reached England, Dr. Goring, in 1824, with the assistance of Mr. Cuthbert, succeeded in greatly improving it, and for a few years this was the most perfect form of microscope manufactured in this country; but, owing to the difficulty in constructing the reflectors, and the great trouble in managing them, this instrument, like the reflecting telescope, fell into disuse; and even Amici himself entirely abandoned it, and returned to his former experiments on the refracting achromatic object-glasses.

In the year 1816, Fraunhofer, a celebrated optician of Munich, constructed object-glasses for the microscope of a single achromatic lens, in which the two glasses, although in juxta position, were not cemented together; these glasses were very thick and of long focus. Although such considerable improvements had taken place in the making of achromatic object-glasses since their first discovery by Euler in 1776, we find that even at so late a period as 1821, M. Biot wrote, "that opticians regarded as impossible the construction of a good

achromatic microscope." Dr. Wollaston, too, was of the same opinion that the compound would never rival the single microscope.

In the year 1823 experiments were commenced in France by M. Selligues, which were followed up by Fraunhofer, in Munich, by Amici, in Modena, by M. Chevalier, in Paris, and by the late Dr. Goring and Mr. Tulley, in London. To M. Selligues we are indebted for the first plan of making an object-glass composed of four achromatic compound lenses, each consisting of two lenses. The focal length of each object-glass was eighteen lines, its diameter six lines, and its thickness in the centre six lines, the aperture only one line. They could be used combined or separate. A microscope, constructed on this principle by M. Chevalier, was presented by M. Selligues to the *Academie des Sciences*, on the 5th of April, 1824. In the same year, and without a knowledge of what had been done on the Continent, the late Mr. Tulley, at the instigation of Dr. Goring, constructed an achromatic object-glass for a compound microscope of nine-tenths of an inch, focal length, composed of three lenses, and transmitting a pencil of eighteen degrees: this was the first that had been made in England, and it is due to Mr. Tulley to say, that as regards accurate correction throughout the field, that glass has not been excelled by any subsequent combination of three single lenses. Mr. Tulley afterwards made a combination to be placed in front of the first mentioned, which increased the angle of the transmitted pencil to thirty-eight degrees, and bore a power of three hundred diameters. Mr. Lister, who was engaged with Mr. Tulley in the perfecting of the achromatic object-glass, finding that all the microscope stands hitherto made were not sufficiently steady for the use of high powers, directed his attention to the improvement of this part of the instrument; and, in order to carry out his views, he employed Mr. James Smith, now one of our first opticians, to execute a stand on the plan represented by fig. 21. This instrument was finished by Mr. Smith, on the 30th of May, 1826, and was the first of the kind constructed in this country with a double stage movement, a diaphragm, and a disc or

dark well for opaque objects, when viewed by a Lieberkuhn. It was also the first microscope made here with a coarse and a fine adjustment. It was supported on three flat feet, capa-

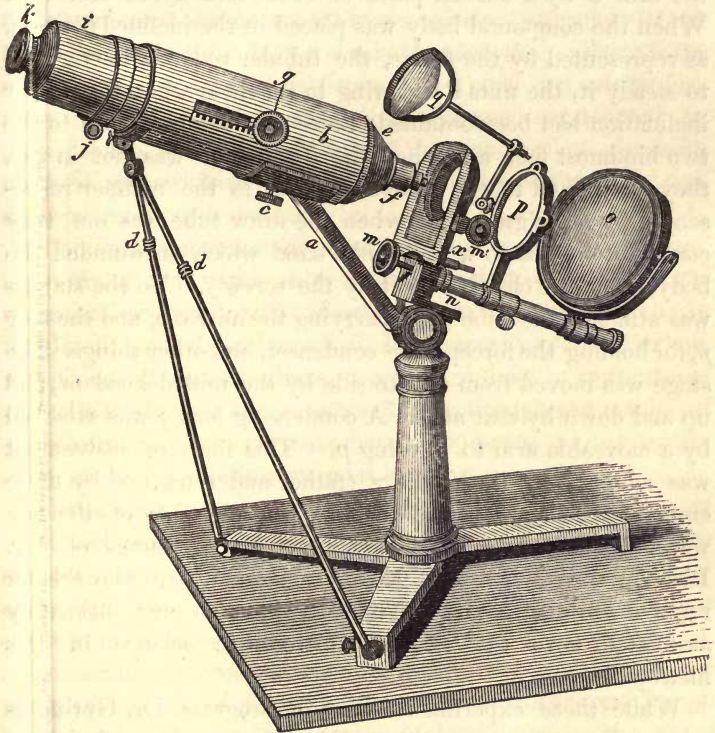

Fig. 21.

ble of being shut up one within the other, for convenience of package; from these a short but stout pillar rose, having at its upper part a cradle joint, to which was attached the stage *x* and the arm *a*, supporting the compound body *b*, which consisted of three tubes, one within the other. Into the inner one *i*, called the draw tube, the eye-piece *h* was screwed: this one was capable of being drawn out from the middle one for the space of four or five inches, and had engraved on it a scale of inches and parts, and to its lower end an erecting glass could be screwed. To the middle tube was attached a rack, with its tube, was moved by a pinion connected with the

milled head *g*, this formed the coarse adjustment, the lower end of this tube *e* was conical, and to it the object-glasses *f* were screwed. The third or outer tube was firmly fixed to the arm *a* by a curved plate of brass and by the screw *c*. When the compound body was placed in the inclined position, as represented by the figure, the tubular rods *dd* were used to steady it, the nuts *dd* serving to fix them when the proper inclination had been obtained; these rods were attached to the two hindmost feet, and when the draw tube was not in use, they were fixed to the compound body in the manner represented by the figure; but when the draw tube was out, they could be applied to a moveable band which surrounded the body, and were clamped to it by the screw *j*. To the stage *x* was attached the tube *n*, for carrying the mirror *o*, and the ring *p*, for holding the forceps, the condenser, and other things. The stage was moved from side to side by the milled head *m'*, and up and down by that at *m*. A condensing lens *q* was attached by a moveable arm to the ring *p*. This form of instrument was adopted by the Tulleys (father and son), and by these eminent opticians some of the first microscopists of the day were supplied with it, amongst whom the names of Mr. Lister, the late Mr. Loddiges, and Mr. Bowerbank require especial notice, as these gentlemen are intimately associated with the rise of microscopic science in this metropolis.

While these experiments were in progress, Dr. Goring is said* to have discovered that the structure of certain bodies could be readily seen in some microscopes and not in others. These bodies he named test objects, he then examined these tests with the achromatic combination before noticed, and was led to the discovery that "the penetrating power of the microscope depends upon its angle of aperture."

On the 30th of March, 1825, M. Chevalier presented to the Society of Encouragement an achromatic lens of four lines focus, two lines in diameter, and one line in thickness in the centre: this lens was greatly superior to the one before noticed, which had been made by him for M. Selligues.

In 1826, Professor Amici, who, from the year 1815 to

* *Microscopic Objects*, p. 21.

1824, had abandoned his experiments on the achromatic object-glass, was induced, after the report of Fresnel to the Academy of Sciences, to resume them, and in 1827 he brought to this country and to Paris a horizontal microscope, in which the object-glass was composed of three lenses superposed, each having a focus of six lines and a large aperture. This microscope had also extra eye-pieces, by which the magnifying power could be increased. A microscope constructed on Amici's plan, by Chevalier, during the stay of that physician in Paris, was exhibited at the Louvre, and a silver medal was awarded to its maker.

“Whilst these practical investigations were in progress,” says Mr. Ross,* “the subject of achromatism engaged the attention of some of the most profound mathematicians in England.” Sir John Herschell, Professors Airy and Barlow, Mr. Coddington, and others, contributed largely to the theoretical examination of the subject, and, though the results of their labours were not immediately applicable to the microscope, they essentially promoted its improvement.

For several years prior to 1829, the subject had occupied the mind of a gentleman who, not entirely practical like the first, nor purely mathematical like the last-mentioned class of observers, was led to the discovery of certain properties in a chromatic combination, which had been before unobserved. These were afterwards experimentally verified; and in the year 1829, a paper on the subject, by the discoverer, Joseph Jackson Lister, Esq., was read to and published by the Royal Society. The principles and results thus obtained enabled Mr. Lister to form a combination of lenses, which transmitted a pencil of fifty degrees with a large field correct in every part. This paper, which was the ground-work of all the great improvements which have been effected in this country in the achromatic object-glasses, has tended to raise the compound microscope from its primitive and almost useless condition to that of being the most important instrument ever yet bestowed by art upon the investigator of nature, and has gained for the discoverer a lasting reputation. As the results

* Art., Microscope, *Penny Cyclopædia*.

arrived at by Mr. Lister are indispensable to all who would make or understand the instrument, I would refer them to the paper itself, which is contained in the 121st volume of the *Philosophical Transactions*. One of the greatest improvements which Mr. Lister introduced into the manufacture of his object-glasses was the joining together of the planoconcave flint lens and the convex by means of some transparent cement, such as Canada balsam; "this," he says, "is desirable to be taken as a basis for the microscopic object-glass, it diminishes very nearly half the loss of light from reflection, which is considerable at the numerous surfaces of a combination. I have thought," he says, "the clearness of the field and brightness of the picture evidently increased by doing this; it prevents any dewiness or vegetation from forming on the inner surfaces, and I see no disadvantage to be anticipated from it, if they are of identical curves and pressed closely together, and the cementing medium permanently homogeneous." From this discovery of Mr. Lister's, in 1829, we may fairly date the rise and continued progress towards perfection of the achromatic compound microscope in England, and all cultivators of natural science, as well as the makers of the instruments themselves, are largely indebted to Mr. Lister for publishing to the world the valuable results of those labours, which certainly have formed the groundwork of the plan on which all our first-rate opticians now work, for whose success he has always most zealously exerted himself, even to the examination, from time to time, of their wonderful productions; and it is but common justice here to state, that we have now in this metropolis three most eminent manufacturers of the compound achromatic microscope, viz., Messrs. Powell, Ross, and Smith, whose instruments are without equal in this or any other country. On consulting the dates at which these opticians respectively commenced the manufacture of achromatic object-glasses, we find that as early as March, 1831, Mr. Andrew Ross had completed for Mr. Wm. Valentine a dissecting microscope on an entirely new plan, being provided with coarse and fine adjustments, and stage movements, and with a Wollaston condenser. This instru-

ment, first described in the forty-eighth volume of the *Transactions of the Society of Arts*, will be more fully mentioned in the chapter devoted to the single microscope; although generally employed for dissecting, it was nevertheless made capable of receiving a compound body. The first microscope of this kind made by Mr. Ross is now in the possession of R. H. Solly, Esq., for which, in 1832, Mr. Ross was also employed to construct a triple object-glass, he, previous to the year 1831, having made lenses of the precious stones and acquired his knowledge of achromatism in connection with Professor Barlow, having operated for the professor during the construction of his fluid object-glass, and also in the arrangement of his formula for computing the radii of curvature of an achromatic one. Since the period above-mentioned, Mr. Ross has been constantly and actively employed in bringing these instruments to perfection, and during the manufacture of the object-glasses, he effected a most important improvement in their construction, which he thus describes :*—" Having applied Mr. Lister's principles with a degree of success never anticipated, so perfect were the corrections given to the achromatic object-glass—so completely were the errors of sphericity and dispersion balanced or destroyed, that the circumstance of covering the object with a plate of the thinnest glass or talc disturbed the corrections, if they had been adapted to an uncovered object, and rendered an object-glass which was perfect under one condition sensibly defective under the other." This defect, if that be called a defect which arose out of an improvement, he (Mr. Ross) first detected, and immediately suggested the means of correcting, and in 1837 communicated his discovery to the Society of Arts in a paper which is published in the fifty-first volume of their *Transactions*, to which paper I would refer those of my readers who would wish to enter more fully into the subject, the desired object being effected by separating the anterior lens in the combination from the other two; and figure 22, which is a section of an achromatic object-glass, will explain how the principles established by Mr. Ross were put

* *Op. Cit.* p. 8.

into practice. A represents a tube, in the end of which the

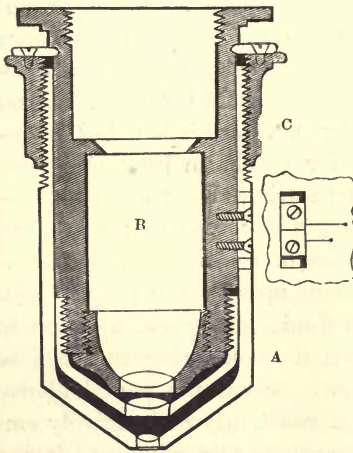

Fig. 22.

anterior lens is set; this slides on the cylinder B, containing the remainder of the combination; the tube A, holding the lens nearest the object, may then be moved upon the cylinder B, for the purpose of varying the distance, according to the thickness of the glass covering the object, by turning the screwed ring C, or more simply by sliding the one on the other, and clamping them together. When adjusted, an

aperture is made in the tube A, within which is seen a mark engraved on the cylinder, and on the edge of which are two marks, a longer and a shorter, engraved upon the tube; when the mark on the cylinder coincides with the longer mark on the tube, the adjustment is perfect for an uncovered object, and when the coincidence is with the short mark, the proper distance is obtained to balance the aberrations produced by glass one-hundredth of an inch thick, and such glass can readily be obtained. When Mr. Ross first effected this improvement, he made the adjustment by sliding the outer tube A upon the cylinder B; but Mr. Powell, we are told, was the first to apply the screw collar C, by which the correction can be performed with greater nicety.

The method of using this improved achromatic object-glass will be again alluded to in the chapter devoted to the compound microscope. From the peculiar construction of Mr. Ross's higher powers, he is enabled to transmit extraordinary large angular pencils of light: on several occasions he has obtained the enormous aperture of 135° .

Mr. Powell, in early life, was engaged in the manufacture of philosophical instruments, but not of microscopes, and it was only in the year 1834 that he devoted his attention to the

last mentioned instruments. In the same year we find a contribution of his to the fiftieth volume of the *Transactions of the Society of Arts*, entitled, "On a fine adjustment for the Stage of a Microscope." This ingenious contrivance was applicable to any instrument, but Mr. Powell used it with the adjustable stage made by Mr. Turrell, and described by him in the forty-ninth volume of the same transactions. The slow movement was obtained by making the stage stand on three feet, under which three inclined planes were moved simultaneously by one screw, a single turn of which raised or lowered the stage only the three-hundredth part of an inch, and twenty divisions marked on the screw-head gave measures of the one six-thousandth part of an inch, and hence its use as a micrometer as well as a fine adjustment. In the year 1841, Mr. Powell made another communication to the *Transactions* of the same society "On a new way of mounting the compound body of a microscope," a plan which will be again alluded to under the head Compound Microscope; and in the year 1840 he succeeded in making an achromatic object-glass of one-sixteenth of an inch in focal length, the first that had been seen in this country, it is in itself a wonderful production, both for delicacy of workmanship and correctness of definition. About this period, his brother-in-law, Mr. P. H. Lealand, who had for some time assisted him in the manufacture of object-glasses, became a partner with Mr. Powell, and from that time up to the present, these opticians have given their undivided attention to the manufacturing, as well as to the improving and perfecting, of the optical and mechanical parts of the achromatic compound microscope.

Mr. Smith, who had been for many years engaged in the manufacture of microscopes of all the ordinary kinds, was in 1826 employed by Mr. Lister to construct the instrument represented by fig. 21; but he did not turn his attention to those of the achromatic form on his own account until 1839, at which time he likewise made object-glasses on Mr. Lister's principles; these, which are of large aperture, are constructed on a plan rather different from those of Messrs. Powell and

Ross, the lowest of them are composed of single triples, and, in order to increase their magnifying power, it is necessary to slide another triple combination over them; by this arrangement, object-glasses of large apertures are obtained, and at a much cheaper rate than those having three pairs of lenses combined to constitute a single magnifying power.

In the year 1841, Mr. Smith was applied to by the council of the microscopical society to furnish them with one of his newly constructed achromatic compound microscopes, and on the 24th of November in the same year, the instrument, of which a figure is given in the second volume of the *Microscopic Journal*, was delivered to the society. This microscope had the compound body mounted on a strong grooved bell-metal arm, the contrivance of Mr. George Jackson, which plan is now adopted by Mr. Smith in all his large instruments; the object-glasses were four in number, the highest being the fourth of an inch, which, with the deepest eye-piece, was capable of magnifying 510 diameters. During the last seven years, Mr. Smith has made many and rapid advances in the manufacture of microscopes, and, in conjunction with his partner, Mr. Beck, has successfully endeavoured to reduce the cost of his instruments by simplifying the form of stand, by which they are brought more within the compass of those whose means are limited.

Amongst those in this country by whose agency the microscope has been much improved, may be mentioned the names of Mr. Varley and Mr. Pritchard, both of whom are well known to the microscopic world by their valuable publications. To the former, in 1831, we are indebted, first, for a microscope with a lever stage movement, for following animalcules, together with capillary cages for containing the same, fishing tubes and other apparatus equally ingenious and useful, and for his lathe for grinding and polishing lenses; secondly, for his vial microscope, for viewing the circulation in chara; thirdly, for his graphic telescope and microscope; fourthly, for his valuable instructions and hints concerning the best forms of eye-pieces for telescopes and microscopes; and, lastly, for his improved lever microscope,

all of which inventions have been fully described in the *Transactions of the Society of Arts*, to which interesting papers I would refer my readers. To the latter, Mr. Pritchard, we are indebted for three valuable works on the microscope, viz:—*The Microscopic Cabinet*, *The Microscopic Illustrations*, and *The Micrographia*, in which are admirably explained the construction of the instruments made and improved upon by Dr. Goring and himself, together with the history of the doublet, jewel, reflecting, and achromatic microscopes, the methods of testing and using the same, with the descriptions of many interesting objects observed by them. These works, which were the first of the kind published in England, have long since obtained a well-deserved reputation. The names of Chevalier, Fraunhofer, Oberhauser, Schiek, and many other continental opticians, here deserve honourable mention for their various productions, and I should be wanting in justice and candour were I not to acknowledge the valuable information which has been derived in this *History of the Microscope* from the excellent work of M. Chevalier, entitled, *Des Microscopes et de leur usage*.

The rapid progress of improvement in the manufacture of the achromatic compound microscope in this country is considerably indebted to the spirit of liberality evinced by the late Dr. Goring and R. H. Solly, Esq., to the patronage of the former we owe the construction, by Tulley, of the first triplet achromatic object-glass, that of the diamond lens, by Varley and Pritchard, and of the improved reflecting instrument of Amici by Cuthbert. To Mr. Solly is due the credit of bringing before the public the improved microscope of Mr. Valentine, the exquisite workmanship of Mr. Ross, and by his intimate connection with the Society of Arts, and his well-known liberality, he has been the means of making its *Transactions*, since 1831, the vehicle through which nearly all the improvements in the constructions of telescopes and microscopes, by Mr. Varley especially, have been made known to the world.

The late Dr. Goring, at whose instigation Tulley, in 1824, constructed the first achromatic object-glass in this

country, said,* in 1829, "that microscopes are now placed completely on a level with telescopes, and, like them, must remain stationary in their construction." "Happily for us," says, Mr. Bowerbank,† "this prediction has not been fulfilled. Admirable as were the combinations alluded to by Dr. Goring, they were very far inferior to those which we now possess, and which we, like the worthy doctor, are, perhaps, inclined to believe are scarcely capable of being surpassed; but however beautiful the combinations around us, let us hope that the same skill and talent which have wrought these great and valuable improvements in the instrument will continue to aid and assist the scientific world, by aiming at and achieving a still further degree of perfection."

The great advances which have been made in microscopic science within the last few years, and the immense number of valuable contributions to animal and vegetable physiology alone, with which the scientific journals of this and other countries are more or less filled, all tend to show with what rapid strides accurate knowledge is being advanced, and the great demand for achromatic microscopes has been such, that since the year 1836, in this metropolis alone, no less than 835 first-rate instruments have been manufactured by our three great makers, Messrs. Powell, Ross, and Smith, to whom with Mr. Lister should be awarded no small share of the honour reaped by those who, through their instrumentality, have successfully laboured in the field of microscopic investigation.

* *Exordium to Microscopic Illustrations*, 1829.

† Address to the Microscopical Society, February 10th, 1847.

CHAPTER I.

THE SIMPLE MICROSCOPE.

The simple microscopes in general use may be divided into two classes; first, into those which are used in the hand; and, secondly, into those which are provided with a stand or apparatus for supporting the object to be viewed, together with an adjustment of the magnifying power to and from that object, with a mirror or speculum for reflecting the light through such objects as are transparent, and a condenser for such as are opaque.

To the first class, or those microscopes which are used in the hand, belong the various kinds of pocket lenses, or magnifying glasses so commonly used; they consist for the most part of double convex or planoconvex lenses of glass, varying in focal length from the quarter of an inch to two inches; one or more of these is set in a frame of metal, horn, or tortoise-shell, and is made to shut up between two other plates of the same material, which, besides forming a handle for it, serve to keep it free from dust and scratches; the shutting up is similar to that of a knife-blade into its handle. Sometimes these lenses are set in pairs, with a thin piece of horn or tortoise-shell between them, which has a hole in its centre corresponding to the centre or axis of the two lenses; this serves as a stop to cut off all the outer rays of light, so that when an object is viewed by the combined power of the two lenses, it is not only more magnified, but the defining power of the instrument is increased in a like proportion, so that we might almost call it a doublet.

These magnifying glasses are extremely useful for all purposes where a high power is not required; to the anatomist they are essential for examining preparations either in or out of bottles, and for dissections and injections. For the latter purpose, a lens of half-an-inch focus will magnify sufficiently to enable an observer to pronounce whether the vessels of most tissues be perfectly filled, or whether extravasations have taken place. In short, no person in the pursuit of any branch of

natural history should be without one: its aid is hourly required. There are two forms of these pocket magnifiers in general use; the most common form is represented by fig. 23,

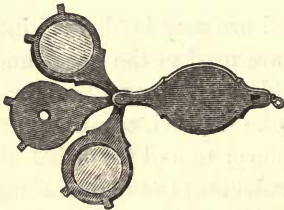

Fig. 23.

which carries only one or two magnifiers, whilst a much larger and more convenient form is represented by fig. 24, in which there are two sets of lenses, varying in their focal length from two inches to a quarter of an inch; between the sets of lenses may be seen in both figures the dia-

phragm or stop, which enables us to use the two lenses as a

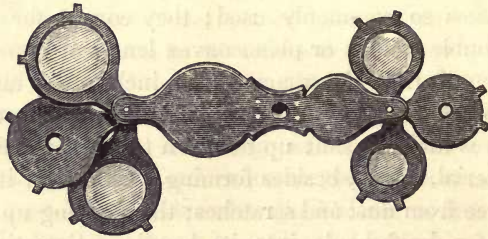

Fig. 24.

doublet. A square hole is made in the end of the handle of fig. 23, and a round one in the middle of that of fig. 24, which serves the purpose of attaching them to a stand, as will be subsequently shown. Mr. Smith generally puts three lenses into one handle, the highest power is a planoconvex, the next a crossed lens, and the lowest a double convex lens, which, when combined, perform uncommonly well.

When a higher magnifying power is required, the form generally used is that known as the Coddington lens, which consists of a sphere of glass, around the equator of which a triangular groove has been cut, and the groove itself subsequently filled up with opaque matter, as represented in section by fig. 25. The great advantage of this form of lens is that, however obliquely pencils of light $B A$ may fall upon it, they, like the central ones, pass at right angles with the surface,

and, consequently, the aberration is trifling. This lens gives a large field of view, which is equally good in all directions, and it little matters in what position it is held, hence it is peculiarly applicable as a hand magnifier. The lens is generally set in silver or German silver, as represented by fig. 26, and the handle is so contrived that it occupies but little room in the waistcoat pocket. It is as well here to mention that many of the lenses sold as Coddington lenses are not constructed after this manner, but are made up of two convex lenses, which are not portions of spheres, hence they are destitute of many of the advantages of the true Coddington lens.



Fig. 25.

Another lens, somewhat of the same description as the last, is much boasted of by its manufacturers, and is puffed off at every toy-shop as the Stanhope lens: it consists of nothing more than a double convex lens of great thickness, on one side of which the convex surface is greater than on the other; and when the least convex or flattest side is turned towards the eye, an object placed upon the other convex surface is in the proper focus of the lens; it is, in consequence, generally used more as a toy than as a philosophical instrument, for viewing the scales of butterflies' wings and other flat objects which can readily be attached to it, or for showing the eels in paste, and the wonders in a drop of water.

When any of these lenses have to be held for a long time in the hand, much inconvenience will be felt, hence various stands or supports have been contrived by which the magnifying power may be kept in a fixed position over the desired object. The engraver, the watchmaker, the jeweller, and the artist, all require some form of lens, and each has some apparatus by means of which it may be supported and adjusted, making it, in fact, a single microscope; and as it would be foreign to our purpose here to enter into the details of the



Fig. 26.

various contrivances which have been adopted, from time to time, we shall merely make mention of those which are useful in microscopical investigations.

The most simple, but not the least useful of the simple microscopes, is represented by fig. 27.

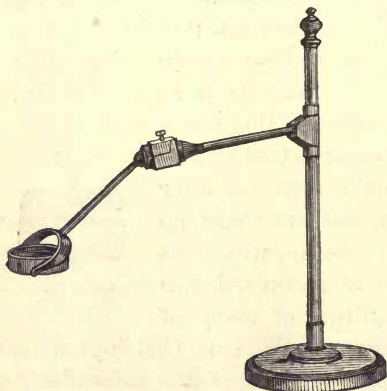

Fig. 27.

It is principally used by watchmakers and wood-engravers, and consists of a loaded stand, of metal or wood, from which rises a circular stem of stout wire or tube; upon this slides another piece of tube, carrying an arm also of stout wire, having at its end a ball and socket joint, and to the ball of this joint is attached a second smaller arm, to

the end of which last is fitted either a spring or else a ring, serving the purpose of carrying the lens; when the spring is used, the magnifier generally employed is the one which the watchmaker adapts to his eye, it is represented by fig. 28, and is nothing more than a lens of an inch focus, set



Fig. 28.

in a long cell of horn, enlarged at one end like a trumpet, and this enables it to be grasped firmly by the muscles around the orbit, or if the ring be used, the lens may drop into it. The coarse adjustment is made by sliding the tube up or down the stem, whilst a finer adjustment is secured by means of the small arm and the

ball and socket joint; but it will be seen that if this last be used, and the arm be moved into any other position than a horizontal one, the lens will not be in a plane at right angles to the object. To remedy this inconvenience, I have found the following contrivance extremely useful, and a section of

the lens and the cell in which it is contained is represented by fig. 29. I have retained the semicircular spring, whose ends

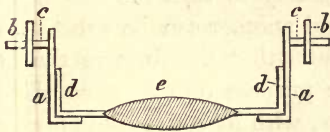

Fig. 29.

are seen in section at *bb*, and entire in fig. 30 at *d*, and have adapted a ring to it *aa*, which is rather less in diameter than the spring, and is three-eighths of an inch in depth; it has a shoulder or

rim at one end, and also two steel pins, *cc*, screwed in near the top edge, exactly opposite each other; these pins are received by two holes made in the semicircular spring, so that the cell may turn or swing upon the pins just as a compass on its gimbals. The lenses are made to drop into this cell, and it will be readily seen by fig. 30, which is a representation

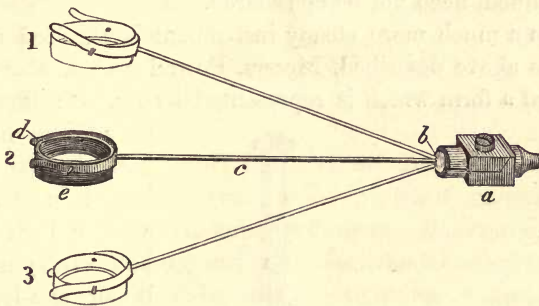

Fig. 30.

of the arm and cell, just one-half its real size, that in whatever position the arm is placed, the cell carrying the lens will be always horizontal:—*a* exhibits the piece of brass which forms the connection between the two parts of the arm, it has a socket at one end, in which the ball *b* works; *c* is the small wire arm which supports the spring *d*; *e* is the cell which carries the lenses; 2 represents the situation of the cell when the arm *c* is horizontal; 1 the same when the arm is elevated; and 3 when depressed, in both of which places the cell maintains its horizontal position.

The lenses are set in brass frames, which easily fall into the

cell, as seen in section in fig. 29, where *e* represents the lens, and *d* the frame in which it is set; and when it is required to change the power, we have merely to turn the cell upside down, the lens will drop out and another can be substituted. It may be as well here to state, that the form of the low power lenses employed for the purpose of dissecting should be double-convex, a planoconvex, with its convex side towards the eye, gives a large and flat field, which is perfect in the centre, but not at the margins. This form of microscope is exceedingly useful for minute dissections of nerves that are carried on under water in troughs or other vessels, and will be found sufficiently steady for the purpose, the length of the arm allowing the lens to be brought over any part of the trough or vessel in which the dissection is contained, so that restriction, as to the size of the subject to be examined, need not be considered.

When a much more steady instrument is required for the purposes above described, Messrs. Powell and Lealand have contrived a form which is represented by fig. 31; it consists

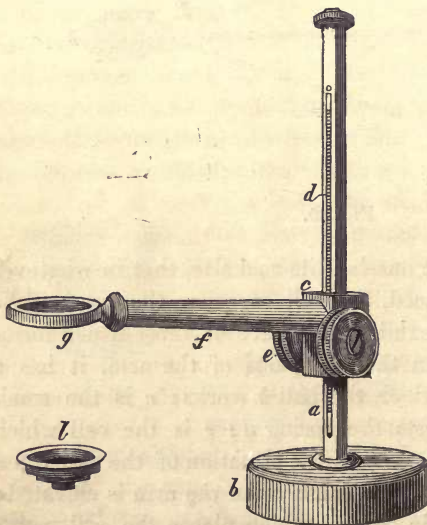

Fig. 31.

of a brass foot, or base *b*, about five inches in diameter, and an inch and a half thick; to make it more steady, it may be loaded with lead; from this foot rises a triangular stem *a*, about twelve inches in length, having a rack *d* on one of its sides; upon this stem, a square box *c*, carrying a pinion and two milled heads, is made to move up and down by the rack. To the box is attached a strong tubular, but conical,

of a brass foot, or base *b*, about five inches in diameter, and an inch and a half thick; to make it more steady, it may be loaded with lead; from this foot rises a triangular stem *a*, about twelve inches in length, having a rack *d* on one of its sides; upon this stem, a square box *c*, carrying a pinion and two milled heads, is made to move up and down by the rack.

arm *f*, nine inches long, which is provided, at its free end *a*, with a stout ring *g*, into which either a compound body may be screwed, as seen in fig. 32, or a lens *l* set in a large cell

may drop. The compound body, it will be seen, has also a rack and pinion motion of one inch in extent for a fine adjustment, and the body itself may be inclined at any angle by means of a swivel joint to the ring. This instrument is particularly useful for minute dissections carried on in large troughs under water; and when the operator wishes to view his dissection with a

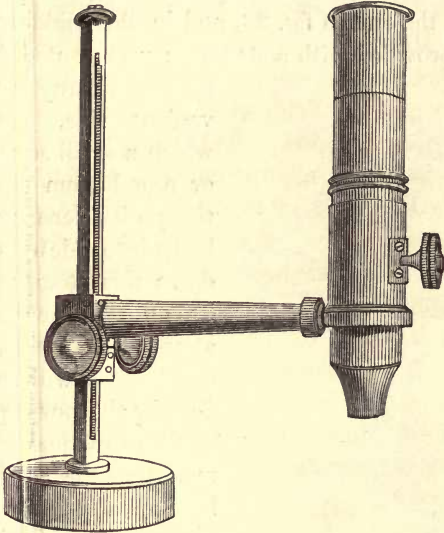

Fig. 32.

high power, he may remove the single lens under which he has been at work, and substitute in its stead the compound body, which is provided with three eye-pieces, and an inch and two inch object-glass; but in no case is he required to move his dissection, as the compound body can be applied to the same objects as the single lens. To make this instrument available for the general purposes of a compound microscope, it is provided with an oblong frame or box, open at the sides, and in the bottom of which is contained a mirror; the top of the box having a hole in it about an inch and a half in diameter, answers the purpose of a stage, and into it a pair of forceps, a frog plate, and other apparatus may be fitted, as into the stage of an ordinary compound microscope. Into the ring, also, may be fitted a small arm, capable of carrying a Coddington or other lens of high power.

When portability is studied, a very convenient and useful microscope, for many purposes, can be readily made with one or both of the pocket magnifiers, before described at page 48, if either of the two forms, as there represented, have a hole in the handle, say at the end in fig. 23, and in the middle in fig. 24, then being provided with a stand, as represented by

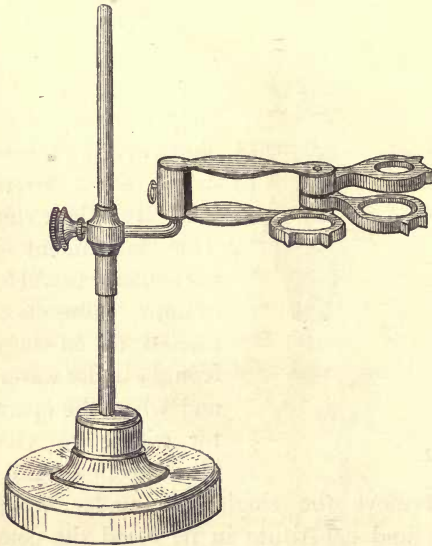

Fig. 33.

fig. 33, of any convenient size, from which a small square or round stem rises, the pocket lens may be made to slide up and down this stem, and if required to be fixed at any given point, a small screw will suffice for the purpose.

This method of mounting the pocket lens on a stand was first suggested by Mr. Lister, and is now manufactured by Messrs. Smith and Beck; but as the plan adopted by them,

which is represented by fig. 33, is rather different from what has just been described, it will be requisite here to give an account of their improvements. Their pocket magnifiers have a square hole in the end, and they use a circular stand, and on the stem, which is round, a piece of brass is made to slide up and down, carrying a binding screw on one side, and a small arm on the other; this arm is straight for about a fourth of an inch, and then is bent at a right angle for about the same length, the last part is square, and upon the square the magnifier is made to fit, this is a much better plan than the first described, where the screw for tightening is in the end of the handle of the magnifier, as less trouble is required in

fixing, and the magnifier itself can be taken off or put on with the greatest facility.

Mr. Ross has contrived a small but exceedingly useful instrument, which answers the same purposes as the preceding; it is represented by fig. 34, and consists of a circular foot

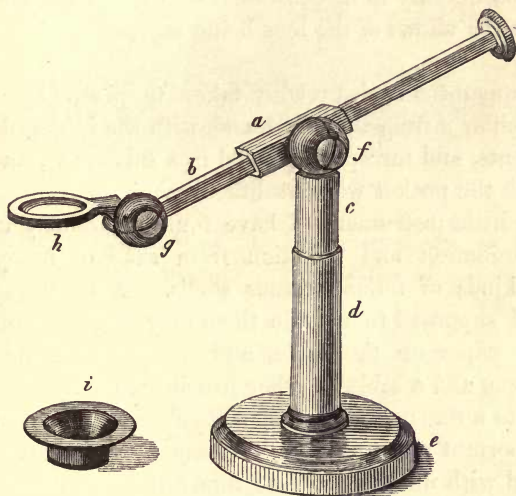

Fig. 34.

e, about an inch and a half in diameter, from which rises a short tubular stem *d*, into which slides another short tube *c*, carrying at its top a joint *f*; to this joint is fixed a square tube *a*, through which a square rod *b* slides; this rod has at one end another but smaller joint *g*, to which is attached a lens holder *h*. By means of the joint at *f*, the square rod can be moved up and down, so as to bring the lens close to an object, or remove it from it, and by the rod sliding through the square tube *a*, the distance between the stand and the lens may either be increased or diminished; the joint *g*, at the end of the rod, is for the purpose of allowing the lens to be brought either perfectly horizontal, or to be inclined at any angle with the subject to be investigated. By means of the sliding tube *c*, the distance between the table and the jointed arm can be increased or diminished. This microscope is provided with

lenses of one inch and one half-inch focal length for the dissection and examination of opaque objects; but by means of a dissecting table or platform, with a mirror underneath, as described with Mr. Powell's instrument, page 53, it will answer equally well for transparent objects, especially if the dissecting rests, subsequently to be described, be used at the same time; the joint at f allows of the lens being adjusted with very great nicety.

This apparatus is also readily taken to pieces, by unscrewing the pillar d from the stand, and, with the lenses, dissecting instruments, and forceps, is packed in a small case, and can be carried in the pocket without difficulty.

These little instruments I have found extremely useful for the examination and selection from sand of many of the smaller kinds of foraminiferous shells. A small quantity of the sand supposed to contain them may be spread on a piece of black paper on the table, and by means of this simple microscope, and a sable or other pencil brush capable of being brought to a fine point, used by a steady hand, a great deal of very important work may be performed in a short space of time, and with much more ease than with a compound instrument, in which all the objects are reversed; and as the cost of these microscopes is comparatively trifling, and the uses to which they are applicable so extremely various and important, no one in the pursuit of natural history should be without one.

The instrument best suited for dissection is one which was described in the forty-ninth volume of the *Transactions of the Society of Arts*, by Mr. Slack. It consists of a box or case, seven inches high and four inches broad, which is represented open in fig. 35. The upper surfaces rr are sloped off to four inches square to form arm rests, and the top is left six inches by four. The front of the case is provided with a flap or door, which has hinges at the bottom and a lock at the top; the mirror is situated in the bottom of the case, and is of large size, and directly over it, in the top, is an opening g , an inch and a quarter in diameter, which may be closed, if required, by a brass cap.

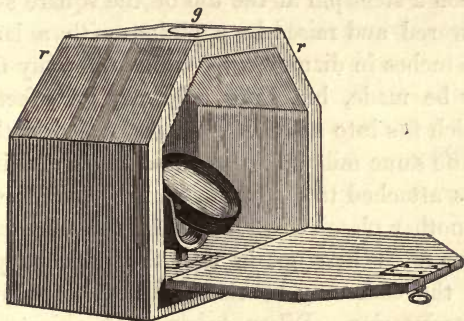

Fig. 35.

Fig. 36 is a back view of the instrument, arranged for use. The stage *h* is screwed into the top of the box, and is raised one inch above it, by means of a tube, in which it is made to

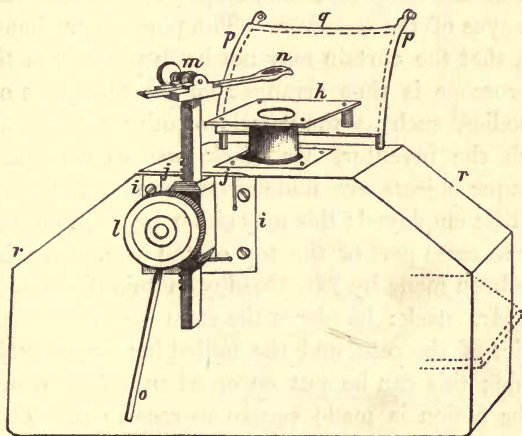

Fig. 36.

revolve, so that an object placed on it may be turned into any convenient position. The apparatus for carrying the lenses and for the adjustment of the same, is represented as it is attached to the back of the case. A vertical stem, six inches long and four-tenths square, with a rack on one side, carries the lens holder *m n*, which may be moved backwards and forwards by a rack and pinion at *m*, and is made to turn hori-

zontally upon a steel pin at the top of the square stem. The stem is lowered and raised by a pinion with a large milled head *l*, two inches in diameter, by which tolerably fine adjustments may be made, but finer still may be effected by the lever *o*, which fits into a series of holes drilled in the circumference of the same milled head *l*. The whole of this adjusting apparatus is attached to a plate of brass *jj*, and is made to slide into another plate *ii*, which is fixed to the back of the case by screws. When not in use, the entire apparatus on the top of the case may be removed and placed in a box or drawer in its interior. When transparent objects are being dissected, the screen *q*, made of black cloth, may be attached in front of the stage by two brass pins *pp*; this screen or curtain has a two-fold use, the one to intercept all extraneous light save that reflected from the mirror below, the other to keep the light of the lamp or candle employed in the illumination from the eyes of the observer. The pins *pp* are bent a little forwards, that the curtain may not be in the way of the head. The microscope is thus arranged for the dissection of transparent bodies, such as the vessels or other tissues of plants, for which the inventor, Mr. Slack, was so celebrated; but when opaque objects are under examination, the condensing lens must be employed; this may either be fixed on a separate stand, or to some part of the top of the case. An improvement has been made by Mr. Goadby in this dissecting microscope of Mr. Slack: he places the stem for the adjustment in the interior of the case, and the milled head only projects on the outside; this can be put on or taken off at will, as the end of the pinion is made square to receive it. The case is on rather a larger scale than Mr. Slack's, but in shape is precisely similar. As most of Mr. Goadby's dissections are carried on under water, square tin troughs are used for the purpose, each of which has a circular ring fastened to the bottom, which fits into the aperture *g* of the stage, and by this means is prevented from shifting its position.

A very useful single microscope is that made by Mr. Ross, and described by him in the *Penny Cyclopædia*, article, "Microscope." It is represented by fig. 37, and consists of a brass pillar,

about six inches long, screwed into a tripod base; to the upper part of the pillar is attached, by screws with milled heads, a

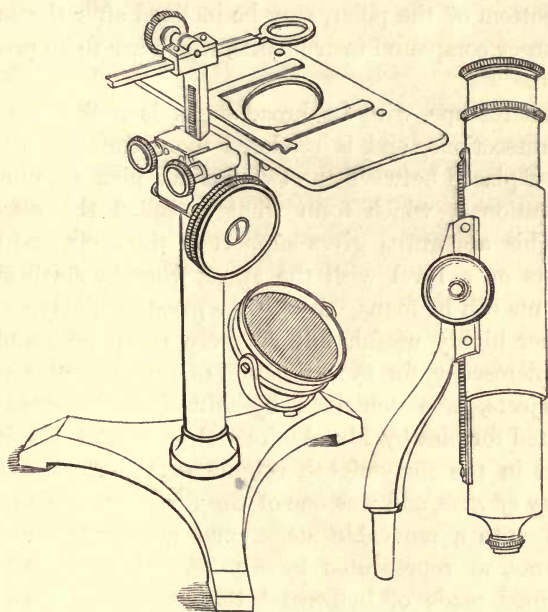

Fig. 37.

large flat stage, provided with a spring clip, and other apparatus for holding the objects. By means of the large milled head, a triangular bar, having a rack, is raised out of the pillar; this bar carries a lens-holder, having a horizontal movement in one direction, by means of a rack and pinion, and in the other direction, by turning on a circular pin. It is also provided with a concave mirror, for reflecting the light through the hole in the stage; a condensing lens, for the purpose of illuminating opaque objects, and a pair of forceps for holding small objects, may be applied to either of the holes in the stage. This microscope is usually supplied with lenses of one inch and one half-inch in focal length for dissecting; but the higher powers generally employed are either doublets or triplets; or this instrument may be converted into a com-

pound one by taking away the lens-holder and substituting for it the compound body represented on the right of the stand, and when provided with a cradle joint, either at the top or bottom of the pillar, may be inclined after the manner of the larger compound instruments, which are to be presently described.

This microscope, with its broad stage, is well adapted for minute dissections, and is rendered more convenient for the purpose if placed between the two inclined planes, to be hereafter mentioned, which form what is called the dissecting rest. This apparatus gives support to the arms, and brings the wrists on a level with the stage, whereby small cutting instruments can be managed with the greatest nicety.

Another highly useful, but far more complete stand of a simple microscope, for the dissection of minute botanical and other objects, was contrived by Mr. Wm. Valentine, and constructed for him by Mr. Andrew Ross, in 1831; it is fully described in the forty-eighth volume of the *Transactions of the Society of Arts*, and was one of the first simple microscopes provided with a moveable stage, and with coarse and fine adjustments, as represented by fig. 38. It is supported on a firm tripod, made of bell-metal, the feet of which *aaa*, are made to close up together. A strong pillar *b* rises from the tripod, and carries the stage *e*, this is further strengthened by two brackets *rr*. From the tube or pillar a triangular bar *d*, and a triangular tube *c*, slide; the one within the other; the outer or triangular tube *c* is moved up and down by a screw, having fifty threads in the inch, turned by a large milled head *v*, which is situated at the base of the pillar, this is the fine adjustment. The small triangular bar *d* is moved up and down within the triangular tube *c* just described, by means of a rack and pinion, turned by the milled head *t*, forming the coarse adjustment: this bar carries the lens-holder *m n o p*. The stage *e* consists of three plates, the lowest one is firmly attached to the pillar, and upon this the other two work. The upper one carries a small elevated stage *g*, on which the objects are placed; this stage is mounted on a tube *f*, and has a spring clip *h*, for holding, if necessary, the objects

under examination. By means of two screws, placed diagonally, one of which is seen at *s*, this elevated stage can be moved in two directions, at right angles to one another,

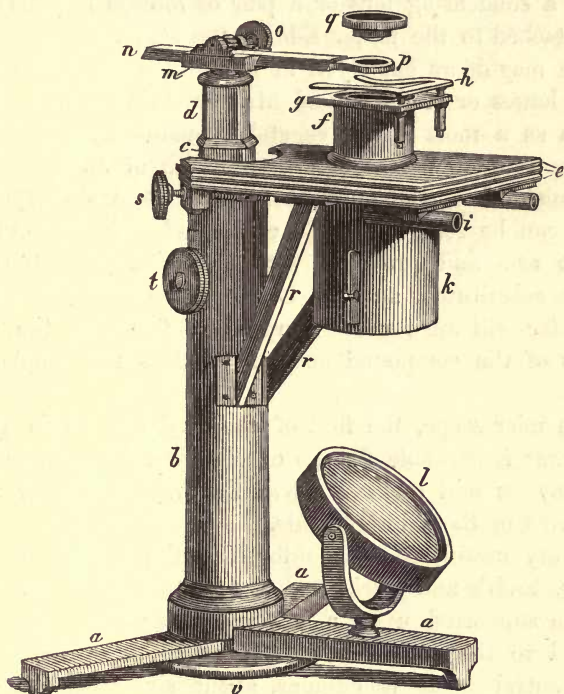

Fig. 38.

and the different parts of any object can be brought successively into the field of view.

The arm *n p*, which carries the lenses, is attached to the triangular bar *d* by a conical pin, on which it can turn horizontally, and the arm itself can be made longer or shorter by means of a rack and pinion *m o* attached to it, hence the lens *g* may be applied to all parts of an object without interfering in any way with the stage.

The mirror *l* is placed upon the largest of the three legs forming the tripod, and consists of a concave and plane glass reflector. To the under side of the stage is fitted a Wol-

laston's condenser *k*, and the lens is made to slide up and down by means of two small handles projecting from the cell in which the lens is set. Two small tubes *i*, into which either a condensing lens or a pair of forceps may be fitted, are attached to the under side of the stage.

The magnifiers employed in this instrument were either single lenses or doublets, and Mr. Valentine, who is so well known as a most skilful vegetable anatomist, has managed to dissect under a lens of one-twentieth of an inch focus.

To make it a compound microscope, the arm carrying the lenses can be removed, and a compound body, supported on a bent arm and provided with a conical pin, at its end, can be substituted, and the coarse and fine adjustments in the pillar will answer the purpose of focussing the object glasses of the compound body, as well as the simple magnifiers.

This microscope, the first of the kind ever made by Mr. Ross, was remarkable for the excellence of its workmanship, and may be said to have paved the way for a new era in the forms of these instruments.

A very useful microscope for dissecting is that made by Messrs. Smith and Beck, and is represented by fig. 39; it may be supported upon a heavy circular brass foot, or be screwed to the cover of a box, or block of hard wood. The central pillar is circular, about six inches long and three-fourths of an inch in diameter, and from it may be raised a triangular bar, by a rack and pinion, turned by two large milled heads. The lens-holder has two movements like that of Mr. Ross, the one horizontally by a pin fitting into the top of the triangular bar, the other by a rack and pinion. The mirror is of the usual construction. The stage is of a circular figure, three inches in diameter; into it may be fitted dissecting troughs, composed of a ring of brass, with a glass bottom, or a similar ring with an ebony bottom, and others equally useful, which are covered or lined with cork. This instrument is supplied with single lenses and with doublets, and has proved a very useful working tool in the hands of Mr. Darwin, who suggested many

ingenious pieces of apparatus to fit into the hole in the stage for holding subjects under examination. Besides this

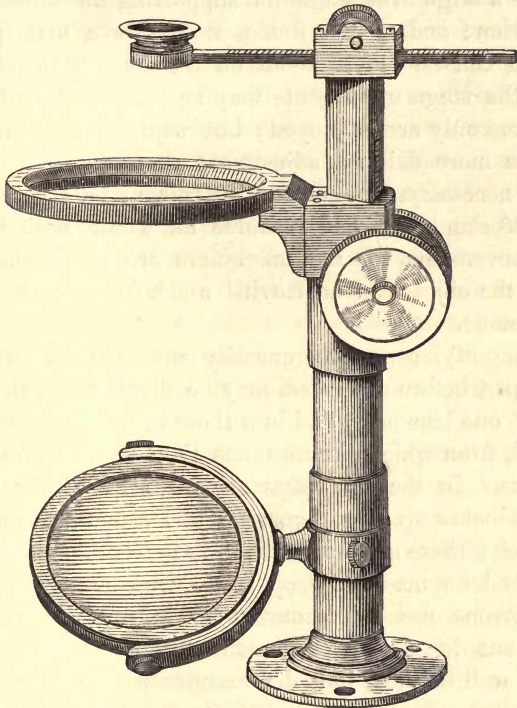

Fig. 39.

single microscope of Messrs. Smith and Beck, and those previously described, there are many very useful forms sold by some of our other opticians in this metropolis, and in the provinces, and those of Mr. Pritchard, which are described in his works, require especial mention. The author of a little tract, entitled *The Wonders of the Microscope*, recommends strongly an instrument invented by Raspail, which can be bought in Paris for thirty francs, or about twenty-five shillings English: it is provided with four lenses, varying in magnifying power from fifty to three hundred diameters. The author was lately shown one of these instruments, by his friend, Mr. H. W. Diamond, and can speak very favourably

of its performance. As the single microscope is principally used for dissection, the most essential part next to good glasses is a large firm stage for supporting the objects under examination; and as it is found, that after a little practice, an object can be moved about on the stage with very great nicety, the stage movements may be dispensed with where low powers only are employed; but with doublets and triplets some more delicate adjustment than that of the hand becomes necessary, and such an instrument as that described by fig. 38 should be had recourse to, where both fine and coarse movements for the magnifiers are provided, and all parts of the object can be carried under the lens by the adjustable stage.

The magnifying powers generally employed with the single microscopes, before described, may be divided into those consisting of one lens only, and into those of two or three lenses combined, from which circumstance they are termed doublets or triplets. In the first class are included all the powers, from two inches up to one quarter, and sometimes one-tenth of an inch; these should be set in flat cells, like that seen in fig. 31, and be made to drop easily into the lense-holder. Some persons use planoconvex lenses for the very low powers; but in these the centre of the field will be perfect and well defined, but the margins not so; hence, both theoretically and practically, it will be found that double convex lenses are certainly the best for low powers, especially for dissecting; but those who are in possession of a two-inch achromatic object-glass, will soon learn that where very careful work is required, a glass of that description will be by far the most pleasant to use. Mr. Powell supplies, with his dissecting microscope, represented by fig. 31, sometimes as many as seven lenses, the four lowest range in focal length from two inches to half-an-inch, and the fifth, a Codrington lens, of a quarter of an inch focus, the remaining two being doublets, one of one-tenth, the other of one-twentieth of an inch focus. Two of these largest lenses are double convex, the other two either crossed or else planoconvex, after the ordinary lens of half-an-inch in focus, the next

increase in the magnifying power should be supplied by the Coddington lens, represented by figs. 25 and 26; this affords a large field, which is equally good in all directions, and its value is intermediate between that of a double convex lens of the best form and a doublet or achromatic lens. The doublet in general use is that which has been before alluded to as the invention of Dr. Wollaston, and is represented in section by fig. 40. It consists of two planoconvex lenses, having their



Fig. 40.

focal lengths in the proportion of one to three, or nearly so; these are set in two separate cells *a c*, the upper one *a* is capable of being moved up and down in *c*, by means of the screw, as represented by the figure; this enables the optician to adjust them to perform accurately. The lenses are placed with their flat sides towards the object, and the one of longest focus, which is also the largest, is placed nearest the eye. Between the two lenses there is a stop or diaphragm *b*, which, for accurate definition, should also be carefully adjusted. This instrument, as described by Wollaston, in the *Philosophical Transactions*, was not provided with a stop, nor does he even allude to the introduction of one; it is not certain, therefore, whether he was at all aware of its value, and his bright career having terminated in so short a time after the publication of his paper, the omission may, in some measure, be accounted for.

Another form of doublet sometimes employed is that which has been described, at page 29, as the invention of Sir John Herschell, it consists of a planoconvex lens and a meniscus, placed in such a manner as that the convex sides of both are in contact. This kind of doublet is not so much used as Wollaston's, in consequence of its focus being rather a mathematical one than otherwise, it does not, therefore, answer so well in practice.

When a triplet is required, it should be constructed on the plan of that of Mr. Holland, first described in the forty-ninth volume of the *Transactions of the Society of Arts*, and before alluded to at page 31; it consists, as is shown in section by fig. 41, of three planoconvex lenses *a b c*, the first two,

a b, being placed close together, and the stop or diaphragm between them and the third lens *c*; this combination of three lenses was used by Mr. Holland, either as a single microscope, or, if required, it could be applied as an object-glass to a compound one; and, although termed a triplet, it is essentially a doublet, having its front lens made up of two. A glass of this form is capable of transmitting as large an angular pencil as 65° with perfect distinctness.

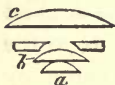

Fig. 41.

This combination of three lenses approaches so very closely to the objects to be examined, that they require to be covered with the very thinnest mica, which is objectionable, and no more than three lenses can possibly be employed to form a single microscope, hence the limit to the improvement of this instrument. Mr. Holland states, that for a triplet to be efficient for the podura, &c., it should be equivalent in power to a single lens of one-twenty-fifth of an inch focus; and in answer to those who object to the use of the triplet, on account of its approaching so closely to the object, he states that some of his preparations are covered with mica so thin, that they can be examined by a spherule of one-three-hundredth of an inch focus. "It was at one time hoped," says Mr. Ross, "as the precious stones are more refractive than glass, and as the increased refractive power is unaccompanied by a correspondent increase in chromatic dispersion, that they would furnish valuable materials for lenses, inasmuch as the refractions would be accomplished by shallower curves, and, consequently, with diminished spherical aberration."* But these hopes were disappointed: everything that ingenuity and perseverance could accomplish was tried by Mr. Varley and Mr. Pritchard, under the patronage of Dr. Goring. It appeared, however, that the great reflective power, the doubly-refracting property, the colour, and the heterogeneous structure of the jewels which were tried, much more than counterbalanced the benefits arising from their greater refractive power, and left no doubt of the superiority of skilfully made glass doublets and triplets. The idea is now, in fact, abandoned; and the

* Art., Microscope, *Penny Cyclopædia*.

same remark is applicable to the attempts at constructing fluid lenses, and to the projects for giving to glass other than spherical surfaces,—none of which have come into extensive use.

CHAPTER II.

COMPOUND MICROSCOPE.

A COMPOUND microscope differs from a simple one in having the image of an object formed by an object-glass further magnified by one or more lenses forming an eye-glass, or, in other words, the rays of light from an object being brought into a new focus, there form an image, which image being treated as an original object by the eye-piece, is magnified in the same way as the simple microscope magnified the object itself. For a microscope to be a compound one, it is, therefore, necessary that it should have an object-glass and an eye-glass; in some of the old microscopes there were only two lenses to answer both these purposes; but it has been stated that in the simple microscope as many as three are employed to form a triplet, and yet, with this number of lenses, the microscope is still a simple one. This is easily explained: the first two lenses of the triplet only effect what might have been accomplished, but not so well, by one; and the third lens is only useful for modifying the light before it enters the eye.

As the object of this work is entirely practical, I shall omit all mention of those compound microscopes that have been heretofore, or are even now manufactured in this country, that are not achromatic, and which, therefore, are unfitted for scientific investigation, and shall confine my observations principally to those made by our three first-rate opticians, viz., Messrs. Powell, Ross, and Smith, all of whose object-glasses will stand the severe tests hereafter to be described; and, as far as we can judge at present, have approached the limits of conceivable perfection, and whose stands or supports

for the same are constructed on the most approved mechanical principles, to prevent tremor and to afford the greatest facility for using the various movements, and, in point of workmanship, are also unequalled.

Every compound microscope may be said to consist, like the simple one, of two essential parts, viz., the stand and the optical apparatus, both of which are very much more complicated than they are in the former instrument. The stand is made up of the compound body (or tube for carrying the optical apparatus), and the stage with the supports and adjustments for each; whilst the optical part consists of the object-glasses or magnifying powers, the eye-pieces, and the mirror. It little matters what the shape or size of the instrument may be; for whatever plan is adopted, or in whatever country it may be made, the parts above described are strictly essential, and must be present in each. The compound body is generally a tube of brass, from eight to ten inches in length, and from an inch to an inch and a half in diameter; to its upper end the eye-pieces are adapted, to its lower the object-glasses; as these latter are of different magnifying powers, and as no two subjects under examination are of the same thickness, it is highly requisite that there should be some mode of focal adjustment applicable to every condition. This is effected in two ways, one of which is termed the coarse, the other the fine adjustment; the first is generally accomplished by rack and pinion, by which the whole of the tube carrying the eye-piece and object-glass is made to approach or recede from the object by turning a large milled head connected with the pinion; whilst in the second or fine adjustment, the object-glass only is moved, and that by means of a very delicate screw, acting either on the long end of a lever or in some of the modes hereafter to be noticed, whereby the same result is obtained. In the best constructed stands, the entire compound body containing the magnifiers is moved up and down by the coarse adjustment; but in many of the older microscopes, as represented by fig. 21, there were two or more tubes to make up the compound body. When this was the case, the outer tube was firmly attached to the

other part of the stand, and formed the guide for the inner one carrying the optical apparatus to slide through; under these circumstances the rack-work was placed in the compound body itself; but much greater stability is ensured by the adoption of the former method. In some instruments there is a third tube connected with the compound body, capable of being drawn out to the extent of five or six inches: this is termed the draw-tube, into one end the eye-pieces fit, and into the other an erecting-glass is made to screw. This draw-tube has a scale of inches and parts engraved on its outer side, as represented by fig. 42, where *a* is the eye-piece, *b* the upper end of the compound body, and *c* the draw-tube, with the scale of inches and parts on it. The many uses of this tube, and of the erecting-glass also, will be fully described hereafter. The inner side of the tube carrying the magnifiers is, in all cases, provided with one or more stops or diaphragms for cutting off the extraneous pencils of light.

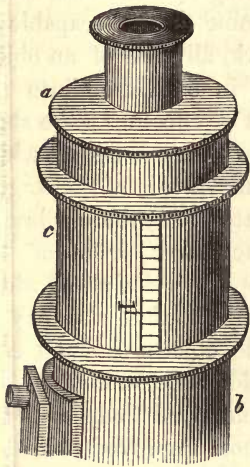

Fig. 42.

The next part of the stand in importance is the stage or apparatus on which the objects are to be placed for examination; this, in the most complete microscopes, consists of two or more plates of brass, one of which, termed the stage-plate, is capable of being moved in two directions, at right angles to each other, either by screws, racks and pinions, by a combination of the two, or, more simply, by a lever. Upon the stage-plate another plate is adapted, termed the object-plate; this last, for the more ready adjustment of the object to be examined, is made to slide up and down upon the stage-plate, and is generally supplied with a raised edge at its lower part, against which the objects themselves may rest when the stage is in an inclined position; and sometimes another piece of brass, termed a clip, with a

weak spring in its front part, is made to slide upon it, so that any object, if necessary, may be firmly secured between the clip and the raised edge. The object-plate, besides the movement up and down on the stage-plate, and that in two directions at right angles to each other, effected by the screws or rack-work, has also a circular one in a horizontal plane, which is accomplished by mounting it upon a short piece of tube, capable of fitting into another tube in the stage-plate; on this tube it turns, and by it the object-plate is also raised above the working parts of the stage-plate itself.

The stage movements are generally limited from half-an-inch to two inches, so that by the sliding up and down of the object-plate, and the distance the same plate is capable of being traversed over by the rack-work, all parts of an object of considerable size can be brought in succession into the field of view. The different methods of effecting these stage movements will be described with the instruments to which they are severally adapted. To the under side of the stage a number of other instruments can be fitted, viz., the diaphragm plate, the achromatic condenser, the lower prism of the polarizing apparatus, and the dark stops or wells, all of which will hereafter be described. To the object-plate also may be fitted the forceps for holding opaque objects, a small condensing-glass, and one of Mr. Ross's side reflectors.

The methods of mounting the compound body and the stage are exceedingly various, the most improved plans are represented in the following figures, and for our present purpose it will be merely necessary to divide them into two classes; first into those in which the compound body is supported at its lower end, on an arm capable of being moved up or down by a rack and pinion; and, secondly, into those in which the compound body is supported, either by an arm firmly attached to the back of it, as seen in fig. 21, when it is necessary that the body should be composed of more than one tube, or where its whole length is supported, after the plan of Mr. George Jackson.

The remaining portion of the stand of the compound microscope consists of the foot or basis, and of one or more pillars

or supports rising from it, to which the compound body and stage are attached. The foot is generally a stout tripod of brass, cast in one piece, or, for convenience of package, it may be composed of three flat feet, capable of being slid one within the other, as in fig. 21, or as in two of Mr. Powell's instruments of three longer legs, standing in an inclined position, like those in a three-legged stool. Some makers even use a heavy circular foot instead of a tripod, but this, although steady when the instrument is upright, is not so when it is inclined. From a foot of one of the above forms a stout pillar rises, having at its upper part a cradle-joint, to which both compound body and stage are firmly attached, so that when the joint is used, both these parts move together. Mr. George Jackson, having found some difficulty in making a good cradle-joint, was induced to use two pillars instead of one, by which a greater degree of steadiness was obtained: his compound body and stage were connected to both pillars by trunnions, on which they were made to turn. Mr. Jackson also mounted his compound body on a grooved bell-metal arm, having two slides, by which the body, when moved up and down by a rack and pinion, was kept steady, a plan somewhat similar to that adopted by Mr. Ross, in one of his early microscopes,* and which will be more fully described in the instruments of Messrs. Smith and Beck, who have adopted it. Mr. Ross uses the tripod foot, and two flat supports, not pillars, by which the same end is accomplished as by pillars; but the supports, he considers, are much more free from vibration. In some of the recently constructed portable instruments, the stage is mounted on a strong pivot, on which it can be turned in a direction at right angles to the compound body; for convenience of package, the smallest instruments of Messrs. Powell and Ross are constructed on this principle.

The optical part of the compound microscope consists of the object-glasses, the eye-pieces, and the mirror. The object-glasses supplied with the best instruments are generally either five, six, or seven in number, and vary in their magnifying power from 20 to 2,500 diameters; they are called two-inch,

* Art., Microscope, *Penny Cyclopædia*.

one-inch, half-inch, one-quarter, one-eighth, one-twelfth, and one-sixteenth; but it must be understood that these names are not derived from the distance the bottom-glass of each combination is from the object, but from a fact found in practice, that a thin single lens, to magnify the same number of diameters as any of the preceding achromatic combinations, would be required to be of the same focal distance as that given to the others by name. In other words, if a single lens were made the object-glass of a compound microscope, and if it were necessary to employ a power equal to that of the one-fourth achromatic combination, with the same compound body, it would be found that a thin single lens of one-quarter of an inch focus would be required to give that power. It would be more useful in practice if the name given to each of the object-glasses were expressive of the magnifying power instead of being derived in the manner above described; and if we take, for instance, the glasses called the half-inch, as constructed by each of our three eminent makers, and compare them together, we shall find that all three will differ, more or less, in their magnifying power, and still they all bear the name of half-inch; nor do two glasses, similar in name and even of the same maker, often agree exactly; hence it would be very desirable in practice to apply a term to them which should express their magnifying power, but such a nomenclature could not at this advanced period be easily carried out.

The eye-pieces supplied with the compound achromatic microscopes are generally three in number, and the form employed is that known by the name of the Huyghenian, it having been first employed by Huyghens for his telescopes. Each one consists of two planoconvex lenses placed at a distance from each other equal to half the sum of their focal lengths, the plane surfaces of the lenses are towards the eye, and that nearest the eye is termed the eye-glass, whilst that most distant is termed the field-glass. A stop, or diaphragm, is placed about half-way between the two lenses; this arrangement was adopted by Huyghens for the purpose of diminishing the spherical aberration by producing the refractions at two

glasses instead of one, and of materially increasing the field of view; but it was reserved for Boscovich to point out that another valuable property of this eye-piece was the correction of a great part of the chromatic aberration as well. This subject has been since critically examined by Mr. Varley, and to his paper, in the fifty-first volume of the *Transactions of the Society of Arts*, I would refer those of my readers who would wish to gain more information upon the matter. Another eye-piece sometimes employed is one the invention of Ramsden; it consists of two planoconvex lenses as in that by Huyghens; but the field-glass is reversed, or its plane surface is placed farthest from the eye-glass; this instrument, which will be again alluded to in the chapter on micrometers, is chiefly used when it is required to measure the magnified image of any object, hence it has been frequently called the micrometer eye-piece, the divided glass being placed immediately in front of the field-lens. When this eye-piece is used, the image of an object is seen in its natural situation; but in the Huyghenian form it is reversed, hence the former has been called a positive eye-piece, and the latter a negative one.

The mirror generally consists of a frame of brass, in which are set two silvered glasses, one concave the other plane, which should not be less than two inches in diameter; the former reflects the light in converging the latter in parallel rays. For facility in adjustment, the frame carrying the glasses is made to turn in every direction, by means of joints, and in the best microscopes it is adapted to a tube on which it can be slid either up or down, and so be approximated to the under surface of the stage, in order that the rays reflected from the concave surface may be brought into a focus or not upon any given object on the stage. In some microscopes the plane mirror is replaced by one made of plaster of Paris, which reflects a soft white light. Mr. Varley has suggested a plan of covering the plane mirror with pounded glass, or carbonate of soda, by which means the light of a bright cloud opposite the sun may be artificially imitated, and even the rays of the sun itself may be reflected, and so produce a soft white light. The different modes of using the mirror will be

alluded to in the chapter devoted to the illumination of microscopic objects, where, also, will be described several other instruments, whereby the quality of the light may be materially modified.

Having now described all the parts essential to a compound achromatic microscope, let us direct our attention to the different arrangements adopted by our three principal makers to render the mechanical part the most effective, and, in doing so, we will, as in all other cases, take the names of the manufacturers in alphabetical order, not giving any preference to the workmanship of one over that of another, but giving always credit where it may be due.

† MESSRS. POWELL AND LEALAND'S ACHROMATIC COMPOUND MICROSCOPE.

This instrument, first described in the *Microscopical Journal*, Vol. I., page 177, is represented by fig. 43, and stands on a firm tripod base of brass, on which is a circular plate, to this two stout pillars are attached, bearing at their upper extremities the ends of the trunnions, on which a strong piece of metal, giving attachment to the compound body and the stage, is supported; by means of the circular plate, the pillars can be turned upon the tripod, and the weight of the compound body and stage brought over one or more of the feet of the tripod, and the instrument, therefore, rendered more steady. This plan of using the double pillar was first applied by Mr. George Jackson, in 1838, and possesses the advantage of being light and of distributing the weight of the superincumbent parts more equally on the tripod than where only one pillar is employed. The compound body is supported nearly the whole of its length on a strong arm, having a hollow frame at its top, after a plan first described by Mr. Powell, in the fifty-third volume of the *Transactions of the Society of Arts*. The coarse adjustment is made by a rack and pinion contained within the frame above noticed, and the latter turned by the large milled head A; in order that the compound body may be moved easily and still be very steady, it is attached to a cradle resting upon two rollers, one inch-and-a-quarter

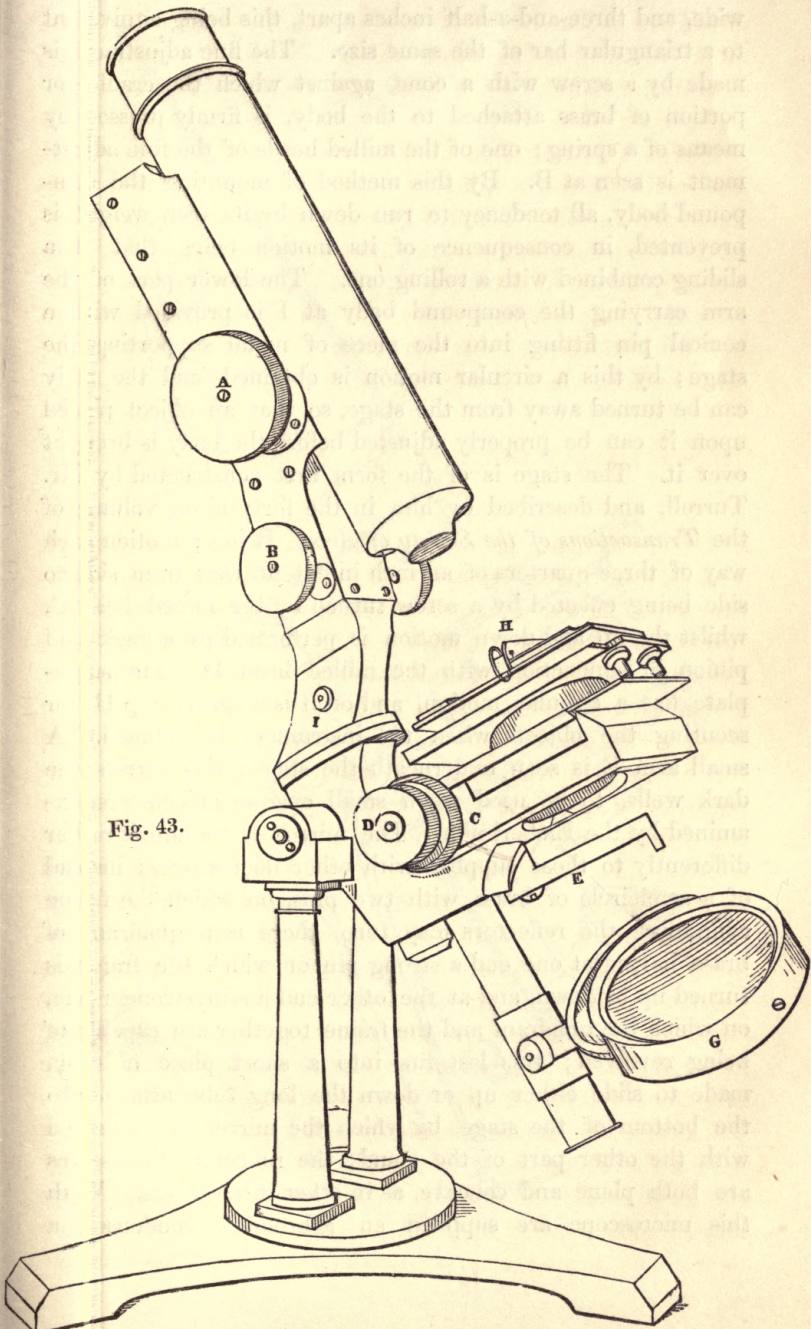

Fig. 43.

wide, and three-and-a-half inches apart, this being equivalent to a triangular bar of the same size. The fine adjustment is made by a screw with a cone, against which the cradle, or portion of brass attached to the body, is firmly pressed by means of a spring; one of the milled heads of the fine adjustment is seen at B. By this method of mounting the compound body, all tendency to run down by its own weight is prevented, in consequence of its motion being that of a sliding combined with a rolling one. The lower part of the arm carrying the compound body at I is provided with a conical pin fitting into the piece of metal supporting the stage; by this a circular motion is obtained, and the body can be turned away from the stage, so that an object placed upon it can be properly adjusted before the body is brought over it. The stage is of the form first constructed by Mr. Turrell, and described by him in the forty-ninth volume of the *Transactions of the Society of Arts*. It has a motion each way of three-quarters of an inch in extent, that from side to side being effected by a screw turned by the milled head C, whilst the up and down motion is performed by a rack and pinion in connection with the milled head D. The stage-plate has a circular motion, and on it is a spring clip H, for securing the objects when the instrument is inclined. A small arm E is seen underneath the stage; this carries the dark wells, to be used when small opaque objects are examined by the Lieberkuhn. The mirror is mounted rather differently to those supplied with other microscopes; instead of a semicircle of brass, with two pins, on which the frame containing the reflectors may turn, there is a quadrant of brass, having at one end a strong pin on which the frame is turned up or down, and at the other end a still stronger one, on which the quadrant and the frame together are capable of being revolved; this last fits into a short piece of tube, made to slide either up or down the long tube attached to the bottom of the stage, by which the mirror is connected with the other part of the stand; the reflectors themselves are both plane and concave, as in other instruments. With this microscope are supplied an achromatic condenser, a

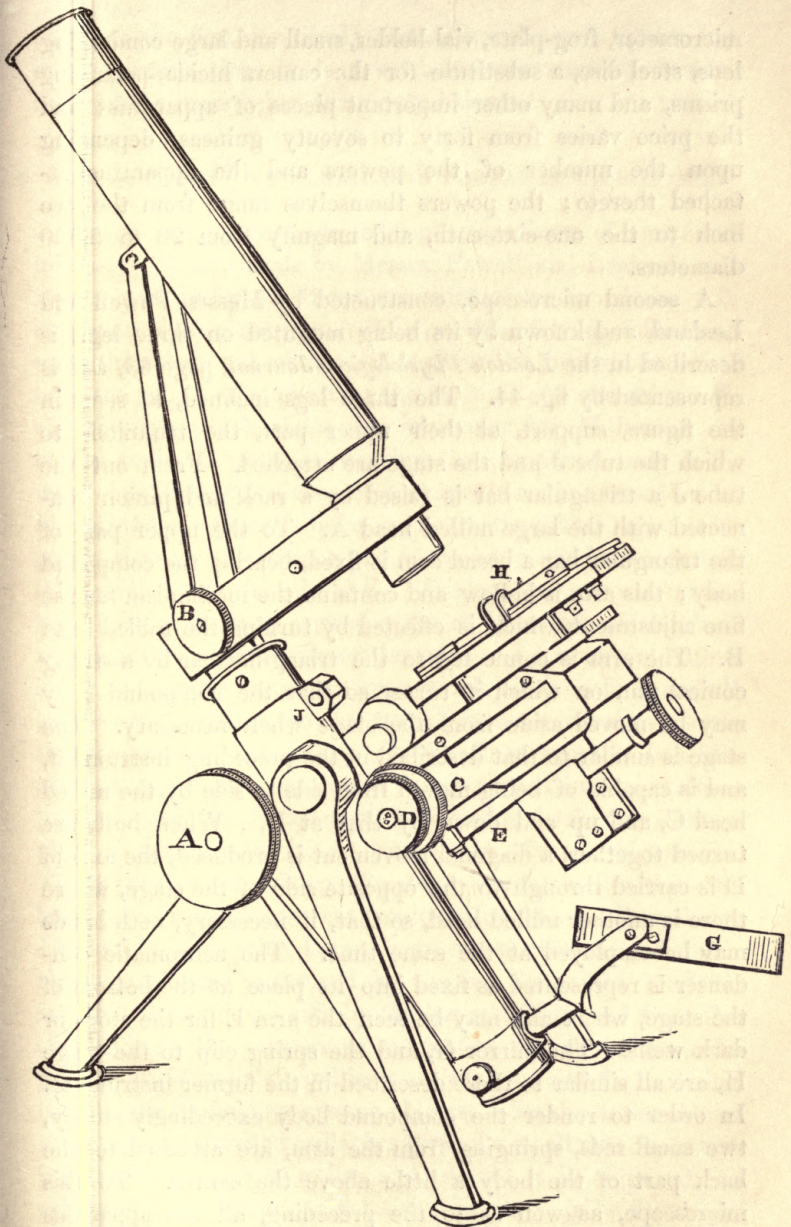

Fig. 44.

micrometer, frog-plate, vial-holder, small and large condensing lens, steel disc, a substitute for the camera lucida, polarizing prisms, and many other important pieces of apparatus; and the price varies from forty to seventy guineas, depending upon the number of the powers and the apparatus attached thereto; the powers themselves range from the two inch to the one-sixteenth, and magnify from 20 to 2,500 diameters.

A second microscope, constructed by Messrs. Powell and Lealand, and known by its being mounted on three legs, is described in the *London Physiological Journal*, page 63, and is represented by fig. 44. The three legs inclined, as seen in the figure, support, at their upper part, the trunnions to which the tube J and the stage are attached. From out the tube J a triangular bar is raised by a rack and pinion connected with the large milled head A. To the upper part of the triangular bar a broad arm is fixed, bearing the compound body; this arm is hollow and contains the mechanism for the fine adjustment, which is effected by turning the milled head B. The arm is connected to the triangular bar by a strong conical pin, on which it turns, so that the compound body may be moved aside from the stage when necessary. The stage is similar to that described in the preceding instrument, and is capable of being moved from side to side by the milled head C, and up and down by that at D. When both are turned together, a diagonal movement is produced, the axis of D is carried through to the opposite side of the stage, where there is another milled head, so that, if necessary, both hands may be employed at the same time. The achromatic condenser is represented as fixed into its place at the bottom of the stage, where also may be seen the arm E for the stops or dark wells. The mirror G, and the spring clip to the stage H, are all similar to those described in the former instrument. In order to render the compound body exceedingly steady, two small rods, springing from the arm, are attached to the back part of the body a little above the centre. To this microscope, as well as to the preceding, all the apparatus there mentioned can be fitted. The stand itself is not so

costly as the first described; and, although much lighter and more portable than it, is nevertheless uncommonly steady, from all the parts being accurately balanced.

† MESSRS. POWELL AND LEALAND'S PORTABLE MICROSCOPE.

One of the most portable and convenient forms of compound microscope is that made by Messrs. Powell and Lealand, and represented by fig. 45, about one-third of its actual size. It is supported on three legs A B C, capable of being folded one upon the other, and when so folded can be brought in a line with the tube D E supporting the stage G and the mirror F, and through which slides the triangular bar H, having attached to it the arm I, carrying the compound body L K, which last, for convenience of package, is made to unscrew at K, and the eye-piece L being removed, the folded legs can be passed through the tubular part of the body, and both together laid parallel with the tube D E. The legs are connected to the tube D E by a strong curved piece of brass M, which winds round to the opposite side of the tube, and a stout pin, with a screw nut, serves as an axis upon which the tube D E, and all that is attached to it, can be turned from a vertical to a horizontal position. The stage G, which presents a box-like appearance, is also capable of being turned into a position parallel with the folded legs, by drawing back the sliding-piece P, which, when in use, keeps it in a horizontal position. The apparatus for moving the stage is contained within the box G, and is similar to that employed by Messrs. Powell and Lealand in their other larger instruments, the up and down movement being performed by turning the milled head N, and that from side to side by the larger milled head O. The slide Q is for the purpose of supporting the object when the microscope is inclined, and in it are two sockets for receiving the forceps for holding opaque objects. To the under-side of the stage are attached a diaphragm and a small arm for carrying the dark stops or wells; and, should it be required, an achromatic condenser, or polarizing prism, may be fitted into the place occupied by the diaphragm. The coarse adjustment

of the instrument is effected by rack and pinion, by which the triangular bar H, and with it the arm I, carrying the com-

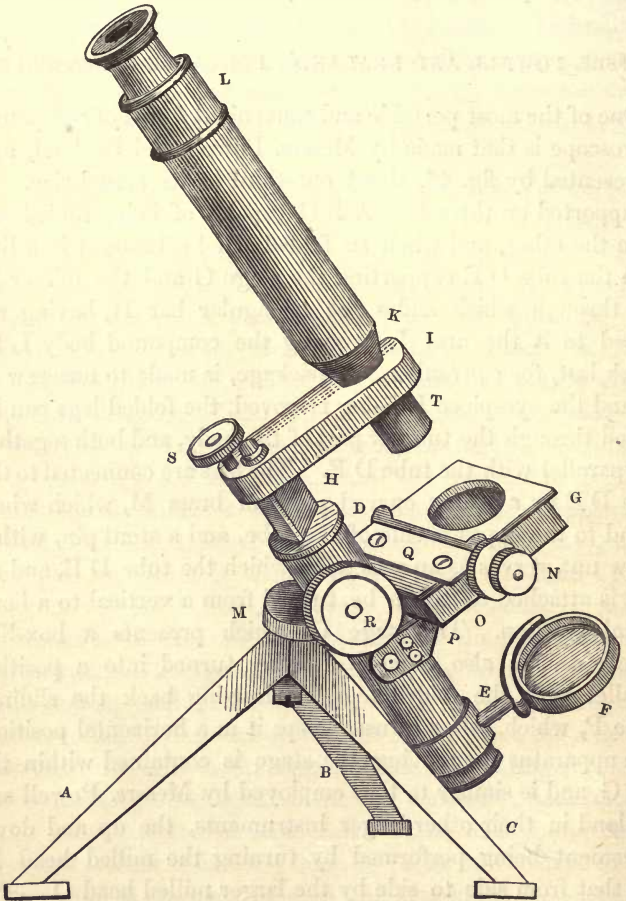

Fig. 45.

pond body K L, are moved up or down, the rack being situated at the back of the triangular bar and the pinion connected with the large milled head R, and the fine adjustment is made by turning the screw S, this acts on the end of a lever contained in the hollow arm I, by which the short tube T, to

which the object-glasses are attached, is slowly raised or depressed. The mirror F is made to slide up and down the tube D E, and being mounted on a semi-circular arm, can be turned in every possible direction.

One great value of this microscope is its extreme portability, as the whole apparatus, consisting of the above described instrument, together with four object-glasses, two eye-pieces, animalcule cage, dark stops, forceps, &c., can be packed in a box, the internal measurement of which is nine inches long, five broad, and two inches deep.

Besides the three preceding microscopes of Messrs. Powell and Lealand, there are two others made by them which require especial mention. The first of these is of large size, and consists of a heavy tripod base, from which rises a short stout pillar, having a cradle joint at its summit, to which is attached a triangular bar, fifteen inches in length, and each of whose sides is one-inch-and-a-quarter broad. To the middle of this bar a stage, seven inches square, is fixed; it has the same kind of adjustments as those of the smaller instruments, being made also on Mr. Turrell's plan; the convenience of the large stage being that the hands do not interfere with the object when adjusting it. The milled heads for effecting the adjustment are placed in a line, so that one hand only is required to move the stage in two directions. The compound body is firmly supported on the upper half of the triangular bar by a frame which fits the bar accurately, and is made to move smoothly up or down by rack and pinion, turned by two milled heads; the compound body is also capable of being turned away from over the stage by means of a joint in the frame supporting it. The fine adjustment is made by an endless screw and two inclined planes; it has also two milled heads, only two inches apart from the coarse, but both horizontal and parallel with them; by this means, the hand may be passed from one to the other very readily. To the lower part of the triangular bar is adapted the mirror, which is of the same construction as that previously described, but is capable of being moved up and down on the triangular bar by rack and pinion; the achromatic condenser is attached

to the mirror, and is moved with it on the bar, so that the axes of its lenses may coincide with those of the object-glasses. To the stage may be fixed all the usual apparatus, and even a frame of large size for holding such objects as are three or four inches broad. The weight of this instrument is very great, and it is remarkable for its steadiness and for the excellence of the workmanship: its price, with all the apparatus complete, approaches nearly to one hundred pounds. In consequence of the great amount of labour expended in its construction, and its necessarily high price, the demand for this microscope has not been great for the last few years, the three previously described having in a measure superseded it. Another very useful microscope for general purposes, made by Messrs. Powell and Lealand, is much less costly than any of the others, the tripod and supports for the compound body and stage being made of cast-iron; the stage is of large size, and they have lately effected a great improvement in it by making it adjustable by a lever; in the stages hereafter to be described with the lever movement; two or more plates are employed, but in this instrument one only is used, and it performs uncommonly well, being very steady even with the highest powers. The compound body is supported on an arm fixed to the back of it, and the coarse adjustment is made by rack and pinion, the fine by a screw acting on the end of a lever. This microscope is available for all the purposes to which the more costly ones are applied, and is particularly useful to the medical student, to whom its low price is also a great recommendation.

MR. ROSS'S COMPOUND AND SIMPLE MICROSCOPE.

This instrument, first described by Mr. Ross, in the *London Physiological Journal*, in 1843, is represented by Plate 1; and as no language of mine could convey so good an idea of its construction as that given by Mr. Ross himself, I will here take advantage of it, and quote his own words:—

“The mechanical construction represented in Plate 1, is derived from a practical acquaintance with the various im-

provements made in the microscope for the last twelve years. The general arrangement, which is properly the province of the mechanic, has been contrived to obtain the utmost freedom from tremor, and to afford the greatest facility in using the various movements, while the extent, direction, and number of these have been collected from the experience of the most indefatigable observers in all the various branches of microscopic inquiry. Nearly three hundred instruments have been made on the plan here represented, and as no alteration or addition has been found necessary for the accomplishment of all the modes of microscopic investigation at present employed, the mechanical structure of the microscope stand may be considered thus far established.

“ The optical part also has arrived at such perfection, that points or lines, whose distance is such that their separation is bordering on interfering with the physical constitution of light, can be distinctly separated; thus ensuring a reality in the appearance of objects, where the minuteness of their detail approaches the natural limit of microscopic vision.

“ *Description of the Instrument, (Plate 1.)*

“ A A are two uprights, strengthened by internal buttresses, mounted on a strong tripod B, at the upper part, and between the uprights is an axis C, upon which the whole of the upper part of the instrument turns, so as to enable it to take a horizontal or vertical position, or any intermediate inclination, such, for instance, as that shown in the plate. This moveable part is fixed to the axis near its centre of gravity, and consists of the stage DD, the triangular bar and its socket E and F, the arm G, which carries the microscope tube H, and the mirror I. The stage DD has rectangular movements, one inch in extent, on the racked cylinders *a a*, and are moved by pinions connected with the milled heads *b b'*; it also has the usual appendages of forceps to hold minute objects, and lens to condense the light upon them. The triangular bar, together with the arm and microscope tube, is moved by the milled heads *ee*, and a more delicate adjustment of this optical part is effected by the

milled head *f*. The other milled head *g* fixes the arm *G* to the triangular bar.

“The outline of the structure, as before observed, has been arranged to obtain, first, the utmost freedom from tremor; and, secondly, to afford the greatest facility in using the various movements.

“In experimenting to obtain the first of these conditions, I suspended the moveable part of the instrument near the centre of gravity, and employed the inverted pendulum (an instrument contrived to indicate otherwise insensible vibrations) to arrange the form and quantity of material, so as to produce, as nearly as possible, an equality of vibration throughout the whole instrument; hence the object upon the stage and the optical part vibrating equally, no visible vibration is caused. The arrangement for accomplishing the second condition is, first, that the whole movements should be as near the base of the instrument as is consistent with the greatest proximity among themselves; then the milled heads *e* and *f* for moving the triangular bar, and the fine adjustment for the optical part, should be moved by the left hand, while the heads *b b'*, for the movement of the stage, should be worked by the right hand. The other milled head *e* is convenient when the right hand may be unemployed with the stage movements. The positions of the milled heads *b b'* are extremely convenient, as the middle finger may be placed under *b*, and the fore-finger under *b'*, and the thumb passed from the one to the other in the most natural and easy manner. The left hand is also readily shifted from the milled head *e*, to employ the fore or middle finger to move the screw head *f*. This head is connected with a screw and lever, which makes one revolution of it move the optical part one-three-hundredth of an inch. This arrangement affords an elastic movement to the end of the tube, as a guard against injuring the glasses or the object under examination.”

MR. ROSS'S PORTABLE ACHROMATIC COMPOUND
MICROSCOPE.

This instrument is represented by fig. 46, and, like the larger one, is supported on a firm tripod base *a*, from which rise two strong uprights *b*, supporting at their upper parts the trunnions to which the square frame *c*, carrying the stage and the tube *d*, are attached. Within the tube *d* a smaller tube is made to slide up and down by rack and pinion, the former is seen at *n*, the latter being turned by the milled head *o*; this forms the coarse adjustment. To the upper part of the inner tube a very stout arm *e* is attached by the screw *f*, on which the arm may be turned; into the opposite end of the arm the compound body *g* is screwed. The fine adjustment consists of a conical-pointed steel screw pressing against the top of a slit in an inner tube, to the end of which the adapter for receiving the object-glasses is fixed. The stage has the usual rectangular motions, that from the side being performed by a screw and nut, by turning the milled head *i*, whilst the up and down movement is performed by rack and pinion, by turning the milled head *k*. The stage-plate is provided with a sliding-rest *l*, by which the distance of an object from the central hole in the plate may be regulated before focussing; this answers the purpose of the complicated sliding frame in the more expensive instruments. At the upper part of this stage-plate there are two holes for the reception of the forceps and side reflector. To the under part of the stage the achromatic condenser, the diaphragm-plate, the dark wells, and polarizing prism, may all be adapted as in the larger instruments; and, for convenience of package, the stage itself may be turned on a pivot, so as to be at right angles with the tube *d*. The mirror *m* is mounted in the usual manner, and is capable of being raised up or down the tube *d*, on which it is supported.

This stand, like the preceding, is constructed on a plan ascertained by Mr. Ross, after a lengthened series of investigations, to be the most steady, and is particularly to be recommended to those whose means are limited, in conse-

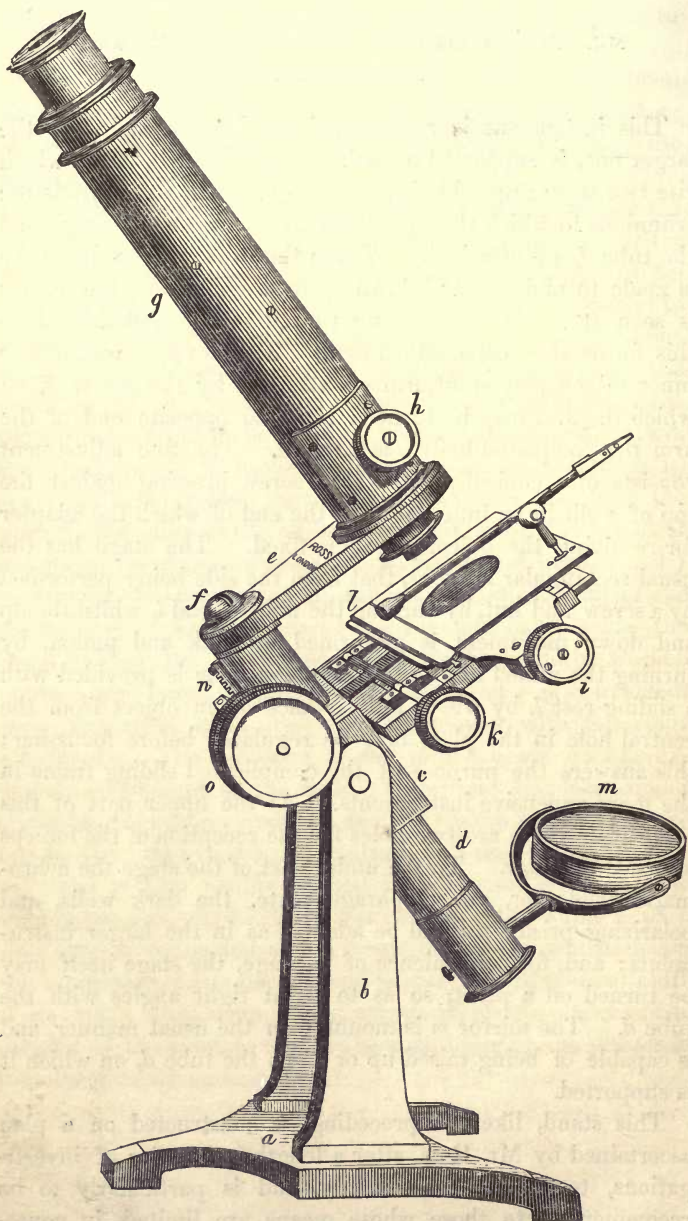

Fig. 46.

quence of its low price, it being of a form which may be added to from time to time according to the wants of the employer; thus, for instance, a vertical stand, with two eye-pieces, exclusive of the object-glasses, may be procured without the stage movements or the fine adjustment, at the small cost of £4 10s.; and as both the stage and the compound body are of the same size in the vertical as in the perfect instrument, the fine adjustment and stage movements may be added to the former at any time, and render it as complete as that represented by fig. 46.

For convenience of package, the compound body may be unscrewed from the arm *e*, and the entire instrument, together with condensing lens, forceps, animalcule cages, &c., be fitted into a case seven-and-a-half inches high, six-and-a-half-inches broad, and five-and-a-half-inches deep; or, if preferred, the foot *a* may be removed from the uprights *b*, and the stage being turned parallel with the axis of the tube *d*, the whole will pack in a flat box seven-and-a-half-inches long, five-and-a-half-inches broad, and two-and-a-half-inches deep.

Besides the two preceding instruments, Mr. Ross has made many other forms. One of the best of these is described and figured in the article "Microscope," in the *Penny Cyclopaedia*; this was the instrument having the middle-third of the compound body supported by a triangular cradle on a bell-metal arm, which suggested to Mr. Jackson the plan of attaching the entire length of the body to an arm somewhat of the same kind, but with dove-tailed slides, for it to move up and down on.

The stage which Mr. Ross adapts to his microscopes differs in some few respects from those employed either by Mr. Powell or Mr. Smith: the movements are effected by two racks and pinions placed at right angles to each other, and either worked by milled heads placed underneath the stage at right angles to the movements, or else as seen in Plate 1, where they are both in the same plane with them; in the portable instrument there is, however, a screw introduced instead of a rack, by which the movement from side to side is effected; but the screw is a fixture, and the stage-plate, with

the milled head attached, is moved backwards and forwards on the screw.

To all Mr. Ross's instruments the achromatic condenser, the polarizing prism, and other apparatus, are capable of being adapted, but there is no draw-tube to the compound body in any of them to be used with the erecting-glass or micrometer eye-piece, as in those of Messrs. Smith and Beck, as the form of eye-piece employed by Mr. Ross does not require such an addition.

MESSRS. SMITH AND BECK'S LARGE ACHROMATIC COMPOUND MICROSCOPE.

This instrument is represented by Plate 2, and consists of a firm tripod base A, upon the centre of which the stout circular plate B is capable of being revolved; into this plate two strong pillars, C, are screwed: these at their upper parts support the trunnions to which the bell-metal arm D, and the stage E, are attached, and by means of which this part of the instrument can be inclined at any angle. The arm supports the entire length of the compound body F on its inner edge, which is ploughed out in such a manner as to receive two brass rods or guides attached to the compound body; one of these, which is soldered to the whole length of the body, is of a triangular figure, and to its apex is screwed a thin flat piece of metal of corresponding length, about five-eighths of an inch broad, and one-eighth of an inch thick, having a rack, or, sometimes, two racks, cut on its outer or unattached side; the former guide fits into a triangular channel ploughed out of the arm, and the latter slides into a channel of the same shape as itself immediately at the back of the triangular one; the triangular guide forms a firm support for the body to rest upon, and the flat guide answers the purpose of keeping the first in close opposition with the channel, whilst by the rack at its back the movement of the body up and down the arm is effected by the pinion connected with the milled head G, which forms the coarse adjustment. There is a draw-tube at the upper end of the body, into which the eye-pieces and erecting-

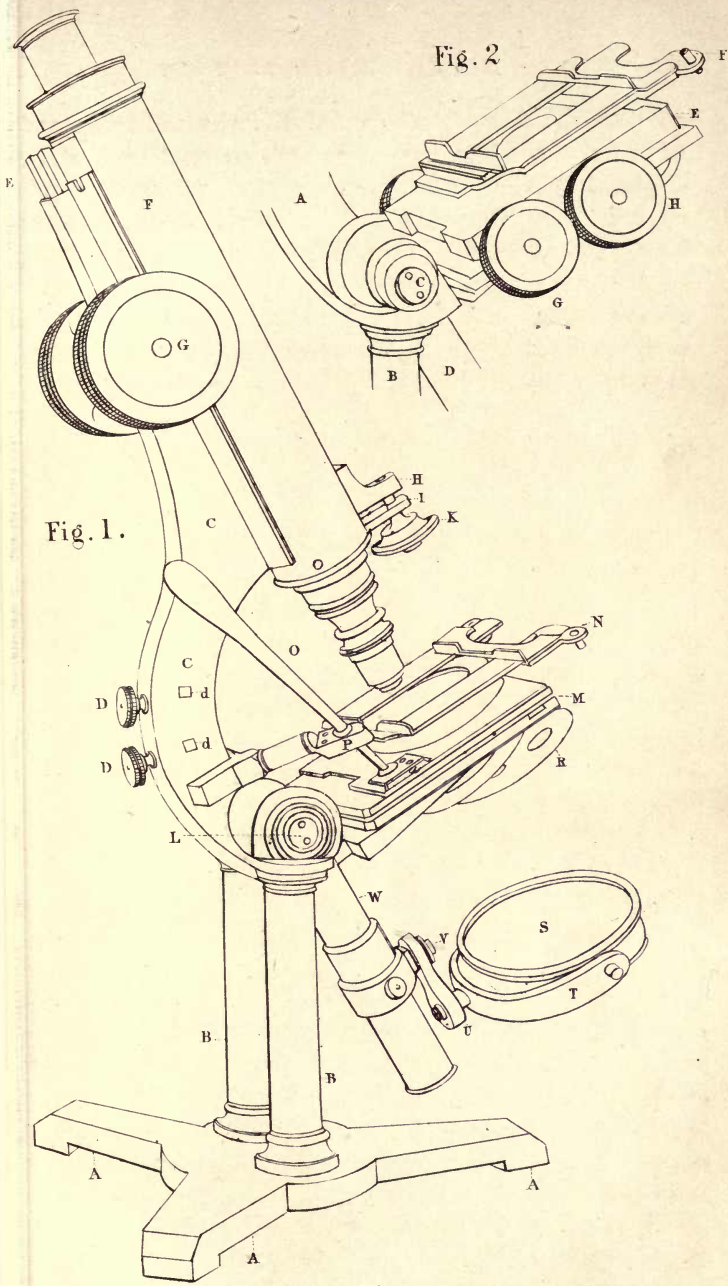

Fig. 1.

Fig. 2

Messrs Smith & Beck's

LARGE ACHROMATIC COMPOUND MICROSCOPE.

glass fit, and to the lower end there is fitted a short tube, carrying the object-glasses; this is moved up and down slowly by the screw H, acting on the end of a lever, and so forms the fine adjustment. The stage adapted to this instrument may be one of two forms, either one whose movements are effected by a lever, or else another constructed on the plan of Mr. Turrell's, in which the up and down motion is produced by a rack and pinion, and that from side to side by a screw whose axis is carried across to the opposite side of the stage, and there can be turned by the left hand. The lever stage is represented as attached to the instrument: this is constructed after the plan of that of Mr. Alfred White, and described by him in Vol. I. of the *Transactions of the Microscopical Society*. It consists of three plates of brass, the lower one of which is fixed, and the other two provided with certain dove-tailed guides and slides, so that the upper one may be moved by a lever, either independently of the middle one, or else be carried along with it. The lever is seen at H, it is about five inches long, and is loaded with metal at its upper part, so as to balance the weight of the stage-plate, and at its lower end is provided with a ball working in a socket connected with the upper plate; about an inch higher up is another ball working in a socket P in a small arm connected with the support of the compound body C C. The dove-tail guides of the middle stage-plate are arranged horizontally, whilst those of the upper plate are placed vertically; when, therefore, the lever *o* is moved either to or from the support of the compound body, both stage-plates will move horizontally in the opposite direction, but when the lever is moved in a line parallel with the side of the same support, then only the upper one is moved; and as the end of the lever to which the hand is applied moves in all cases in an opposite direction to that of the ball *a*, and as the compound microscope always inverts the image of the object under examination, the object will appear to move in the direction of the hand. The object-plate is provided with a spring clip N, capable of being slid up and down, and of being turned upon the upper plate of the stage, and is always moved

with it. To the under side of the stage the diaphragm R is seen attached. Mr. White's lever stage, of which the above described is a modification, is represented by fig. 47, as fixed for use to the lower end of the arm supporting the compound

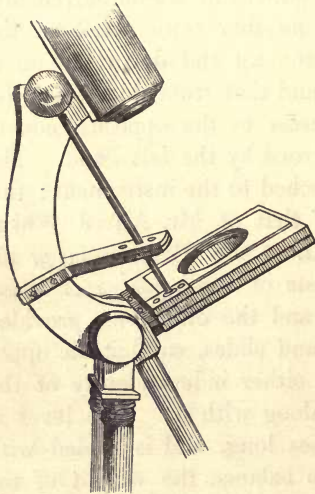

Fig. 47.

body. The mirror S is of large size, and is mounted on a tube W; it has a plane and a concave reflecting surface, the frame is supported by a semicircular piece of brass T, with two pins for it to turn on, at U is a joint on which it can be moved horizontally, and at V another joint for turning it away from the axis of the instrument, so that very oblique light may be sent through the hole in the stage, and by means of the short tube it may be slid up and down on the support W. In the arm C C

may be seen two square holes *dd*, into these the supports of the side reflector and of the small condensing lens are made to fit, and are kept firmly fixed by the screws D D.

To this instrument, if preferred, another stage may be fitted, as exhibited in Plate 2, fig. 2, where A represents part of the large arm for supporting the compound body, B one of the pillars, C the joint, and D the tube for the mirror. The stage-plate E, carrying the object-plate F, is moved from side to side by the milled head G connected with a screw whose axis passes through to the opposite side of the stage, where there is another milled head, and up and down by a rack and pinion connected with the milled head H. This stage is a very steady one, it being a modification of that of Mr. Turrell before alluded to.

Fig. 1.

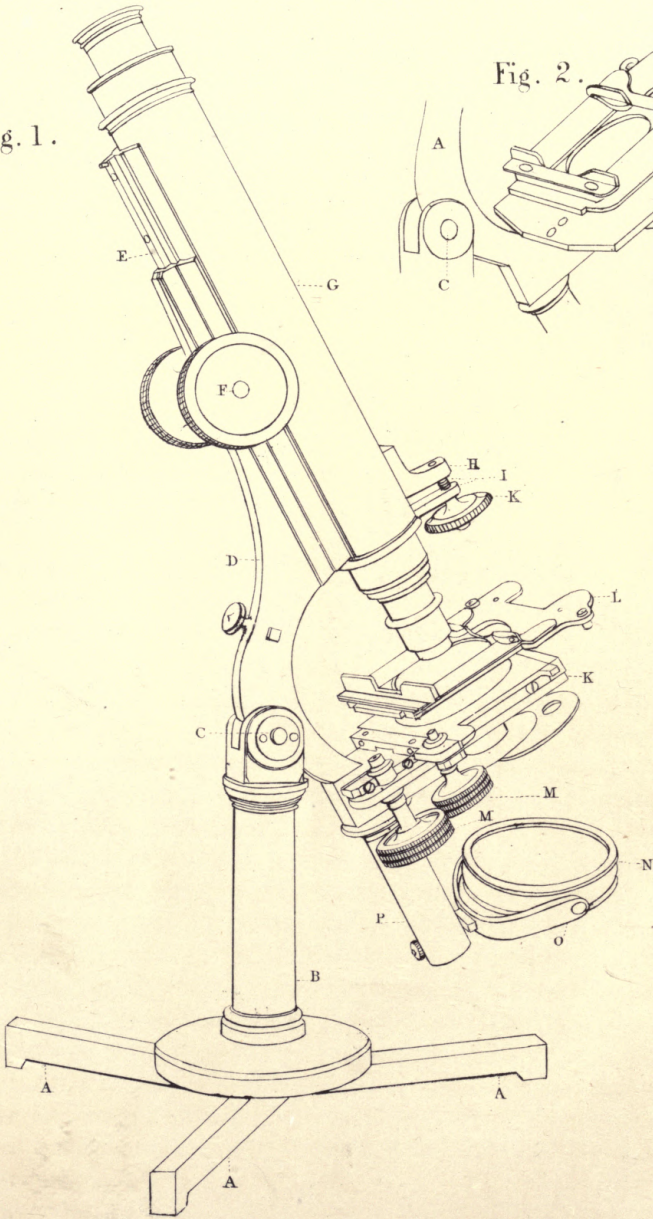
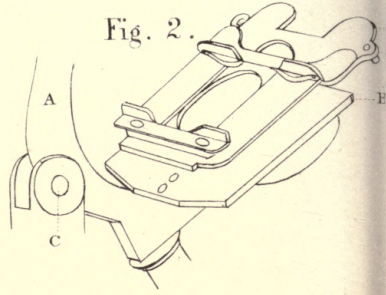

Fig. 2.



Messrs Smith & Beck's

SMALLER ACHROMATIC COMPOUND MICROSCOPE.

MESSRS. SMITH AND BECK'S SMALLER ACHROMATIC
COMPOUND MICROSCOPE.

This instrument is represented in Plate 3, fig. 1; it is mounted on three feet A, capable of being slid one within the other; into a circular plate attached to these feet is screwed a pillar B, having a cradle joint C at its upper part; to the joint is attached a bent arm D, grooved like that of the larger instrument, and supporting in a similar manner the compound body G, the triangular guide and rack being seen at E. The milled heads F are for the coarse adjustment. At the bottom of the compound body there is attached a small tube, into the lower end of which the object-glasses are screwed, and to its upper end a lever, the short extremity of whose long end I is capable of being moved up and down by the fine screw K working in the nut H, and so forming the fine adjustment; the tube is kept tight against the screw by a spring, which, when the object-glass is accidentally brought in contact with any object on the stage, allows of its retreating for a short distance, and, in most cases, prevents either the object or the object-glass itself from being fractured, hence it has obtained the name of the safety-tube. To the lower end of the arm D the stage K is screwed; this consists of two plates, which are capable of being moved in two directions at right angles to each other by racks and pinions connected with the milled heads M M. The object plate L is precisely similar to that in the preceding instrument, and to the under side of the stage all the usual apparatus may be fixed. The mirror N is mounted in the ordinary way upon a semicircular frame O, having a pin passing through a piece of cork in the end of the tube P, on this it can be turned horizontally. To render this a cheaper instrument, the stage shown at fig. 2 may be substituted for the adjustable one. A represents part of the arm supporting the compound body, B a plate of brass attached by screws to the lower end of the same arm, C the joint at the upper part of the pillar. Upon the Plate B is supported the object-plate D, capable only of being moved by the fingers in two directions, the one vertically and the other circularly.

On account of the feet folding one within the other, this microscope can be packed in a flat box, the thickness of which is regulated by the breadth of the stage. When more portable and less expensive stands are required, the two following deserve especial notice.

MESSRS. SMITH AND BECK'S ACHROMATIC COMPOUND
MICROSCOPES FOR STUDENTS.

Fig. 1, Plate 4, represents the largest of these instruments. The base is composed of brass, cast in one piece; it stands on three feet A A A, from which proceed the two flat, upright cheeks B B, having a trunnion joint at C, on which the stage and the compound body are capable of being turned. Into the plate H is screwed a stout tube L, within which slides another tube supporting the straight arm M. This last is ploughed out in the same manner as the arm in the larger instruments, and the compound body N, resting on the guides O, is moved up and down it by turning the milled head P. The tube within that at L, to which also the arm M is attached, is provided with a spiral spring, that keeps the arm M always firmly in contact with the plate I; against this last the fine screw K, with a graduated milled head, presses; when the screw is turned, both the arm M and the compound body are moved slowly up or down, forming the fine adjustment. The spring is prevented from forcing the arm M out of the tube L by a stop situated just above the milled head K, which is not represented in the figure. The stage is a plate of brass, about four inches long and two inches wide, having dove-tail grooves, in which the frame G, for holding the objects, slides up or down, it being readily moved by two small handles projecting from it: one of the ends of the frame is provided with a socket F for the reception of the forceps and other instruments. The mirror D is mounted in the usual manner on the semicircle of brass E, and is capable of being turned on a large pin fitting into the end of the tube which is attached to the under surface of the stage.

The second microscope is constructed much on the same plan

Fig. 1.

Fig. 2.

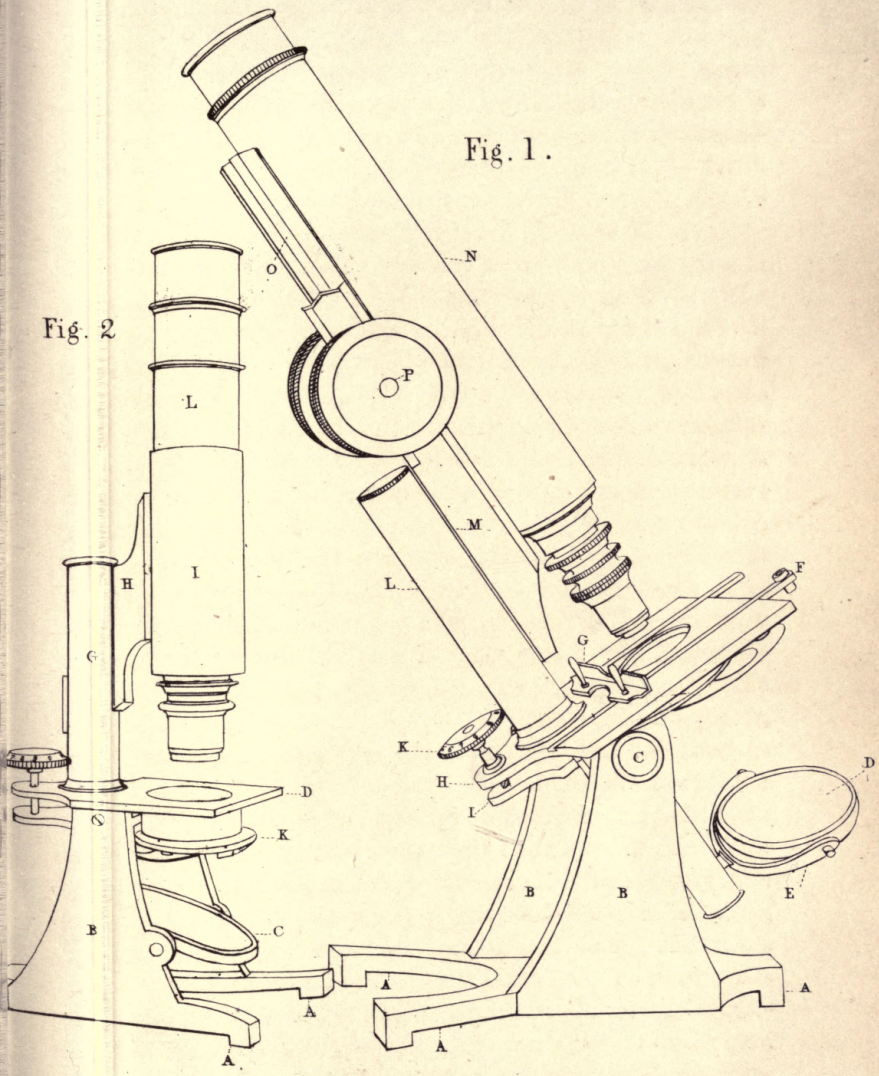

Messrs Smith & Beck's

ACHROMATIC COMPOUND MICROSCOPES FOR STUDENTS.

as the last described, but is much smaller, and is only capable of being used in the upright position; it is represented by fig. 2. The stand is supported on three feet A A A, having two flat upright cheeks B connected with them, to the top of these the stage plate D is fixed. The tube G is screwed into the upper surface of the stage-plate. Within it, as in the larger instruments, a smaller one slides, having the arm H supporting the tube I connected with it. Through the tube I slides very smoothly up and down the compound body L, carrying the eye-pieces and object-glasses; this forms the coarse adjustment, whereas the fine adjustment is made by turning the screw with milled head E, which either raises or depresses the arm H and the entire compound body L I with it in the same manner as was described in the preceding instrument. A diaphragm K is fitted into the bottom of the stage-plate. The mirror C is supported on trunnions working in the front part of the cheeks B; but having only a circular movement, hence it is required that the light to illuminate objects should be always in front of it. A stand of this description is exceedingly useful for keeping on the table where dissections are going on, as small portions of the different tissues can readily be placed under a quarter-of-an-inch object-glass, and be examined as they are removed, the shortness of the stand allowing of its being used without much trouble; and almost all objects, for temporary purposes, being mounted in fluid between glasses, they are apt to slip down when placed on the stage of an inclined instrument, and as all the large microscopes are too high to be used on a table at which dissections are carried on, without either being inclined or the dissector being obliged to get up from his seat every time an object placed between glasses, with or without fluid, is required to be examined in the horizontal position, this little instrument is extremely useful for such purposes, and two of such, one provided with a power of forty, the other with that of two hundred, should be always at hand; they would be most efficient working tools, and the cost without glasses not exceeding £3. The sliding up and down of the body L in the outer tube

I, forms a very good coarse adjustment, whilst, after the object-glass has been brought sufficiently near the object, by this means, the fine will answer for the remainder. The height of this instrument, when the compound body and draw-tube are shut down, is not more than eight inches, and it is not much too large to be carried in the coat pocket. With all these microscopes the usual accessory instruments are supplied, if required; many of them differ in some points of construction from those both of Messrs. Powell and Ross, and with them will be fully described in the chapter devoted especially to the consideration of these subjects.

Before concluding this chapter, the author would direct the attention of his readers to the compound microscopes of Mr. Pritchard, fully described in the last edition of his *Microscopic Illustrations*, where will also be found full directions for the construction of proper stands, and the methods of using the various microscopes and the pieces of apparatus supplied with them, with numerous illustrations to explain the same, all of which subjects will repay an attentive perusal.

A compound microscope constructed by Mr. Varley, and described by him in the fifty-fifth volume of the *Transactions of the Society of Arts*, as the *Single Lever Microscope*, here also requires especial notice. This instrument is represented by fig. 48, one-third of the real size, and consists of a hollow foot, somewhat like that of a bird's in shape, from which a stout pillar rises, having at its top a thick, flat disc of brass *a*, with a central hole; to this the microscope is joined by means of a strong block *b*, whose face is turned to fit against it, a central screw passes through the hole, and all the important parts of the instrument are kept fast to the block by the screw nut *c*. Through the block *b* slides the long rod *d*, against which a saddle is placed for the screw *e* to bind it fast at any height. To the same block *b* the back plate of the stage *g* is fastened, from this is given off the arm *r*, which, in connection with the shorter arms *q q*, supports the fulcrum of the lever *s*, having attached to it two balls, the lower one of which works between two plates at *p*, and the upper one between two others at *t*; to the upper of these last

as one to six. To enable both sides of the stage-plate *h* to move simultaneously, a parallel motion is added, one of the rods of which is seen at *w*. Whichever way the balls and sockets move, the stage-plate *h* obeys their motions, and an observer, with the lever in his hand, may follow the motion of any living object. By an error on the part of the artist, fig. 48 is reversed, the lever should be on the right hand.

To the lower part of the stage is fitted either one of Mr. Varley's dark chambers, or else a Wollaston condenser: Mr. Varley prefers the former, as it is more free from colour. To the lower part of the tube *z*, into which the rod *d* slides, is seen the mirror; this, as in Mr. Powell's microscopes, is mounted on a bent arm, and, if necessary, by means of a sliding tube, may be moved up or down the tube *z*. The tube of the compound body 1 is mounted by means of a hollow case or trough 2, having two arms 7 upon the rod *d*, and is kept firmly fixed in any position by means of a screw with a milled head and a bent spring. To the back of the tube is soldered a rack, this is connected by two saddle-pieces 3 with a bar 4. A pinion held in a spring, made of plate-brass, as wide as the trough, is attached by a screw to its inner side, and the milled heads which turn the pinion are seen on either side of the same trough; by either of these the coarse adjustment is effected. Through the upper part of the tube 1 slides that part of the compound body which supports the eye-piece, and to the lower end is attached a bent arm, through which works the milled head-screw 12; above this is another bent arm connected to a smaller sliding tube bearing the object-glasses; within this tube is a spiral spring, the action of which causes the tube to be pushed out; but this is prevented by the long arm of a lever 11, against which the screw presses. When the screw, therefore, is turned, the arm 11 is either raised or depressed slowly, and by this the fine adjustment is accomplished. A condensing lens 27 is most conveniently held by a moveable arm, the curve 29 and joint 30 allow it to be moved to or from the stage, either vertically or horizontally, so as to suit every purpose. For convenience of package, or for applying Mr. Varley's graphic eye-piece to this instrument, the compound body and its supports 7 may be

removed from the rod *d*, and the rod itself may be drawn out of the tube *z*, so as to allow of any object not more than three inches thick to be examined under a lens of two inches focus. Amongst other advantages in this microscope, there is added to it a small piece of apparatus, by which a phial having chara growing in it, or animalcules adhering to its inner surface, may be examined in a vertical position: many of these last would, in all probability, be shaken off if the phial were turned about when inclined. Also, by the addition of the graphic eye-piece, the tracing of all kinds of objects, whether magnified much or little, can be readily accomplished. The price of this microscope, exclusive of the object-glasses, varies from £20 to £30. Another very excellent form of microscope is that constructed by Mr. Dancer, of 43, Cross-street, Manchester; it consists of a firm tripod of brass, from which rise two stout pillars, bearing at their upper extremities the truunions that support a slightly curved arm, to which the stage and compound body are attached, somewhat after the plan of that of Mr. George Jackson. The compound body itself consists of two tubes, the outer one being attached to the arm by two saddle-pieces with screws; this tube is sprung at either end, and within it a smaller one can be moved up and down by rack and pinion, turned by a large milled head; this forms the coarse adjustment, whereas the fine is effected in a similar manner to that in Mr. Smith's and Mr. Varley's instruments; viz. by a lever attached to the small tube carrying the object-glasses, which is moved either up or down by a fine-threaded screw. The stage is about four inches long, and two-and-a-half broad, and on it slides an object-plate longer than the stage-plate, but about half its breadth. To the front of the stage may be fixed the forceps and a large condensing lens, if necessary. The mirror is of the usual form, and is capable of being moved up or down the tube that connects it to the under surface of the stage, and can also be inclined at any angle. With this microscope Mr. Dancer supplies the usual amount of object-glasses and other apparatus, and to the correct performance of the former I am happy to add my willing testimony; and although they do not surpass those of

the three principal makers in this metropolis in their defining and penetrating power, they are, nevertheless, capable of exhibiting remarkably well the usual test objects, and are, on account of their cheapness, highly to be recommended. The stand itself is very well planned, and the manner in which the workmanship is executed, reflects very great credit on the manufacturer; and, both for its utility and for the comparatively low price at which this instrument can be furnished, viz. from £10 to £20, complete, it is well worthy the attention of those whose means are limited. Report speaks well of the stand of a compound achromatic microscope constructed by Mr. King, of Bristol, but I have never yet had an opportunity of examining an instrument of his manufacture.

Having now described all the important points in the construction of our English microscope stands, whereby great steadiness, accuracy of adjustment, portability, and other valuable requisites have been so successfully carried out, we will now direct our attention to the apparatus that may be added to any instrument to render it complete for all the purposes of scientific investigation.

CHAPTER III.

ACCESSORY INSTRUMENTS.

BESIDES the object-glasses, the eye-pieces, and the mirror, together with the parts constituting the stand of a microscope, such as the compound body and the stage, with the supports and adjustments for each, it has been found in practice highly essential that certain other instruments of great utility should be supplied with the best microscopes. These may be divided into two classes; first, into those which are subservient to the illumination of objects, and, secondly, into those for the purpose of keeping objects in whilst they are being examined, or for preparing the same for examination. Amongst the former may be mentioned all the various kinds of diaphragms, condensers, polarizing apparatus, dark wells, &c.; and amongst

the latter, the live boxes, animalcule cages, fishing tubes, &c., all of which require special mention.

The Diaphragm.—A very useful piece of apparatus applied to the under surface of the stage in most microscopes is the diaphragm, represented by fig. 49: it consists of two or more plates of brass, one of which is perforated with four or five holes of different sizes; this plate is of a circular figure, and is made to revolve upon another plate by a central pin or axis; this last plate is also provided with a hole as large as the largest in the diaphragm-plate, and corresponds in situation to the axis of the compound body. To ascertain when either of the holes in the diaphragm-plate is in the centre, a bent spring is fitted into the second plate, and rubs against the edge of the diaphragm-plate, which is provided with notches, so that when either of the holes is brought into its proper position, the end of the spring drops into the notch. The space between the largest and smallest hole is greater

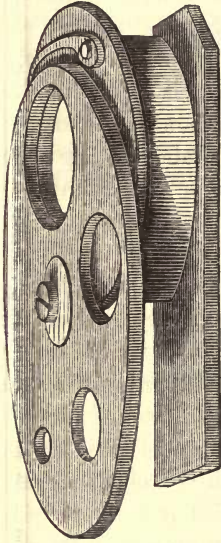

Fig. 49.

than that between any other two, this answers the purpose of stopping off all the light if necessary. This instrument is attached to the under surface of the stage, either by a sliding-plate, as seen in the figure, or else by a short piece of tube fitting into the hole of the stage, and securely fixed in the proper position by a bayonet-joint. The former method is adopted by Mr. Ross and Mr. Smith, and the latter by Mr. Powell; every part of this instrument through which the light passes should be made black, so that no other rays than those from the mirror should interfere with the illumination.

The use of the diaphragm is to modify the rays reflected from the mirror, and to limit the angle of the pencil of light which shall be allowed to fall on the object under examination. When a very bright light is employed for some time, the eye

will often suffer greatly from fatigue, and when taken away from the instrument, a dark spot will be seen upon any object that is white; to remedy this inconvenience, that part of the diaphragm-plate where no hole is may be supplied with a piece of grey or neutral tint glass, and when the light is passed through either of these, it is so very much softened, that the relief afforded to the eye is truly astonishing.

Dark Chamber.—This instrument, like the diaphragm, is fitted to the under surface of the stage, and is represented by fig. 50; it consists of a plate of brass *c*, into which is soldered

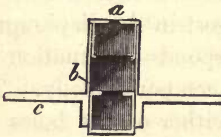

Fig. 50.

a short piece of tube, having a diaphragm or stop *a*, in which is an aperture equal to what can be viewed through the lens, and no larger; below this is a sliding tube *b*, with an aperture rather larger than that at *a*; this last can be moved up and

down until the light at *a* is of the greatest intensity, the aperture at *a* being always in proportion to the size of the lens employed; this instrument is the contrivance of Mr. Varley, and is described by him in the forty-eighth vol. of the *Transactions of the Society of Arts*. He applies it always to his instruments, and on account of there being no lens in its construction, the light is not decomposed; he, therefore, prefers it to the Wollaston light for a condenser. It is always employed with his phial-holder, and will be again alluded to.

Wollaston Condenser.—This instrument, like the preceding, is also fitted to the under surface of the stage; it consists of a short tube, in which a planoconvex lens of about three-quarters of an inch focal length, is made to slide up and down; this apparatus is represented in section by fig. 19, or as applied to a microscope in fig. 38, where the lens, set in a frame, is moved up or down by two small handles. For correct definition, Dr. Wollaston employed a stop immediately above the mirror, between the mirror and the lens, whereas it has been found much better in practice to apply the stop between the lens and the object: this improvement was the invention of Dr. Goring, and is very convenient to use, as the

length of tube employed is much shorter than what Wollaston suggested, and the definition is greatly improved by the arrangement. Dr. Wollaston states that "the intensity of illumination will depend upon the diameter of the illuminating lens and the proportion of the image to the perforation, and may be regulated according to the wish of the observer."

Achromatic Condenser.—The condenser of Wollaston, just described, although a very great improvement over the ordinary methods of illuminating, is, nevertheless, to a certain extent, faulty, in consequence of not being supplied with an achromatic lens; to remedy this inconvenience, M. Dujardin, in 1840, contrived an instrument which he termed an *eclairage*, for the purpose of illuminating objects with achromatic light, a modification of this apparatus is now supplied with all the best microscopes, and is known as the achromatic condenser; and although it is applied in different ways to the microscopes of our three eminent makers, it, nevertheless, consists of three essential parts; viz. an achromatic combination, an adjustment of focus for the same, and a means of making the axes of the object-glass and of the condenser coincide exactly. When the compound body is made to turn away from the stage, the apparatus for adjusting the axes is very simple, and the plan adopted by Mr. Ross and Mr. Powell is represented by fig. 51;

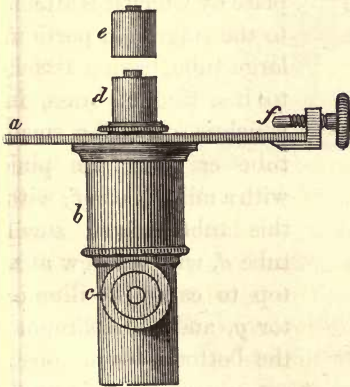

Fig. 51.

it consists of two tubes, sliding one within the other, to the outer one *b*, is attached a flat plate *a*, which slides underneath the stage, and is adjusted for distance by the screw *f*; at *c* is seen a milled head, which is connected to a pinion, and by means of a rack attached, the inner tube, carrying the achromatic combination *d*, is raised or depressed; the upper part of the outer tube is larger than that where the

milled head is seen; this is for the purpose of allowing the milled ridge of the achromatic combination to pass up and down freely. For the low powers, such as the half and quarter of an inch, the combination *d* only is used; but with the higher powers the second part *e* may be slipped over *d*, whereby the focal point of the illuminating rays will be materially lessened in diameter, although it is increased in brilliancy. The flat mirror is generally used as the reflector or the prism to be presently described.

When the compound body can be turned away from the stage, the adjustment of the axes of the illuminator and object-glass is a very simple matter, the only movement required in the condenser is that of either increasing or diminishing the distance the flat plate *a* has to slide through; this is done either by screwing or unscrewing the screw *f*, until the spot of light formed on the object by the illuminator is in the centre of the field of the object-glass. But when the compound body is a fixture, then it is necessary that the condenser should have

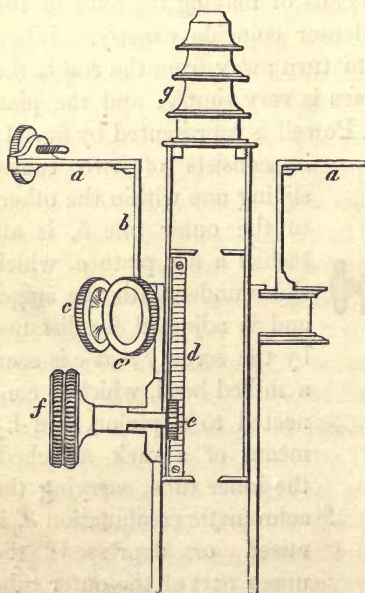

Fig. 52.

two or more adjustments; a section of such a condenser is represented by fig. 52, as constructed by Mr. Ross. *a* exhibits the plate by which it is attached to the stage, *b* a portion of large tube, having attached to it a ring of brass, into which is soldered a smaller tube carrying the pinion with a milled head *f*; within this tube a still smaller tube *d*, with a screw at the top to carry the illuminator *g*, and a diaphragm at the bottom, to cut off all extraneous light, is moved up and down by a rack, in which works the pinion *e*.

The vertical adjustment of this instrument is made by the small screw attached to the plate *a*, whilst all the other movements are effected by turning three or more screws in the ring of brass, by which the inner tube carrying the illuminator, can be moved in various directions, so as to bring the axis of this glass to coincide with that of the object-glass. Two of these screws are seen at *c* and *c'*. This plan was first suggested by Mr. Ross, and is adapted to all his instruments in which the arm carrying the compound body is a fixture. The several parts of the illuminator *g* unscrew, so that they may be used either combined together or separate.

The achromatic condenser supplied with the largest microscopes of Messrs. Smith and Beck, is represented by figs. 53 and 54; and for the better exhibition of its several parts,

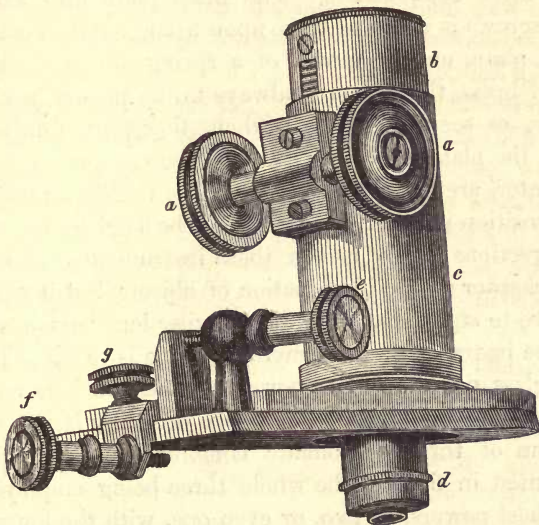

Fig. 53.

the drawings have been made of the actual size, but in an inverted position. In fig. 53, *c* represents a tube of brass, within which a smaller tube *b*, carrying the illuminator *d*, is moved up and down by turning the milled heads *a a*. The tube *c* is screwed into a plate of brass, which turns upon another larger

plate; by this last the entire condenser is adapted to the under surface of the stage, it being provided with a screw *f* at its

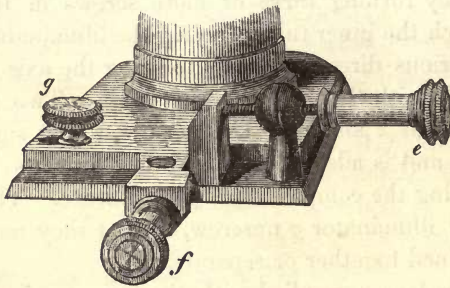

Fig. 54.

front part, to regulate the distance that it should be slid in under the stage, so as to bring the illuminator *d* into the axis of the object-glass; but as the arm supporting the compound body does

not move from side to side; the adjustment, to remedy this, is rather more complicated. The brass plate into which the tube *c* screws is made to turn upon a large pin, fixed to the bottom plate, and by means of a spring and a small raised block of brass, the former is always firmly pressed against the screw *e*, as seen in fig. 54; when, therefore, this screw is turned, the plate, and with it the tube *c*, together with the illuminator, are carried slowly from side to side, and when the exact position is found, the plate may be fixed by the screw *g*. Full directions for the use of these instruments will be given in the chapter on the illumination of objects, but it may be as well here to state, that if an illuminating lens be not supplied with the instrument, the general practice is to adapt to it the object-glass next lowest in power to that which is employed with the compound body; but where economy is not studied, a system of three achromatic combinations is supplied, as represented in fig. 54, the whole three being employed with the highest powers, or two, or even one, with the lowest.

Polarizing Apparatus.—This consists of two prisms of calcareous spar, constructed after the plan of Mr. Nicol, of Edinburgh, and composed each of two pieces of the same spar, cemented together so as to transmit only one image. One of these is mounted in a tube, and adapted to a flat plate of brass, as represented by fig. 55, by which it can be applied to the under surface of the stage-plate, like the achromatic con-

denser; upon this plate the tube carrying the prism is made to revolve by turning the large circular plate at the bottom with

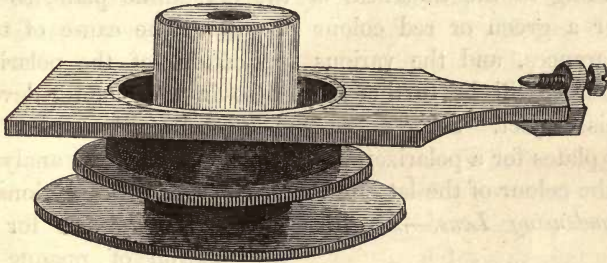

Fig. 55.

a milled edge; this lower prism is termed the polarizer, in contradistinction to another fitted to the top of one of the eye-pieces, and termed the analyzer. An end view of one of the prisms is seen at fig. 56, and a vertical section at fig. 57;

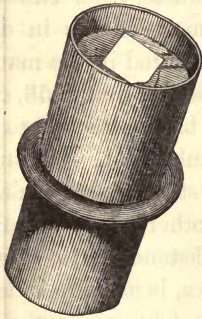

Fig. 56.

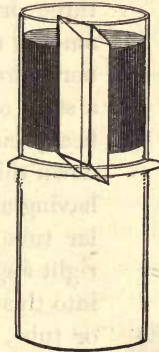

Fig. 57.

when applied to the microscope it is as necessary that the axes of both crystals coincide with each other and with the other optical parts of the microscope, as was mentioned for the achromatic condenser; this may be known by revolving either of the prisms after the light has been sent through them by the mirror. If they are properly ad-

justed, it will be found that there are two positions in which no light will pass through the prisms at all; if this does not take place, and only part of the field of view is darkened, then, either by turning the arm which carries the compound body or the screw in the plate that bears the polarizer, the two can be made to obscure each other; they are then in a condition to be used. If now a crystalline plate of sulphate of lime be placed in the focus of the object-glass, it will be seen that this crystal, in common with many others, has the

property of bending the rays of light that have traversed the polarizer, and of causing them to pass through the analyzer; according to the thickness of the crystalline plate, so will either a green or red colour prevail. The cause of these appearances, and the various applications of the polarizing apparatus, will be further alluded to in the chapter devoted to this subject. Some microscopists employ a bundle of thin glass plates for a polarizer, and a tourmaline for an analyzer; but the colour of the latter often renders its use objectionable.

Condensing Lens.—An indispensable instrument for the

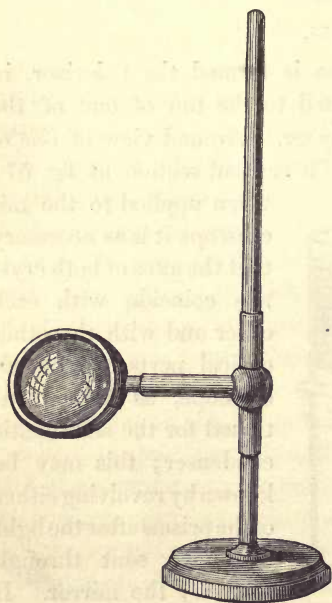

Fig. 58.

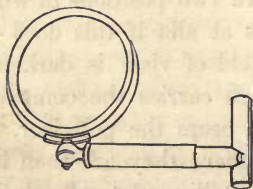

Fig. 59.

a swivel-joint, as seen in fig. 59, so that it can be brought

illumination of opaque objects, or of the mirror when a great quantity of light is required, is the condensing lens or bull's-eye. This is generally a planoconvex lens of great thickness, from two to three or more inches in diameter, mounted in the manner represented by fig. 58, on a stem of brass attached to a heavy circular foot. Up and down this stem a short tube, having another piece of similar tube fastened into it at right angles, is made to slide; into this last fits a short rod or tube, which supports the lens and allows its being inclined at any angle. This method of mounting the lens is adopted by Messrs. Ross and Powell; but Mr. Smith, following Mr. Tulley, employs the same kind of stem and foot; and, in addition to being inclined at any angle, the lens is provided

near to the lamp or candle used as the illuminating body without moving the other parts of the stand.

Another very convenient way of mounting the condensing lens is represented by fig. 60, as adopted by Messrs. Smith

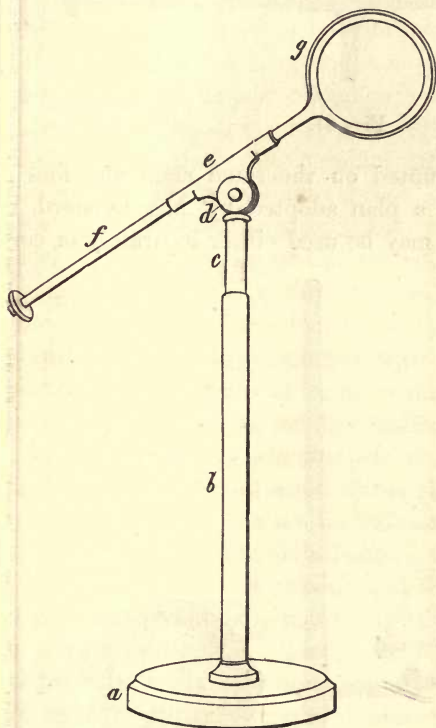

Fig. 60.

and Beck; the foot *a* is the same as in the other instrument; but instead of a solid stem, it is provided with a short tube *b*; into this slides a smaller one *c*, having at its upper extremity a cradle-joint *d* connected with a small tube *e*, through which slides a wire arm *f*, supporting a small condenser *g*. This plan of mounting a condensing lens is very convenient: it has all the motions of the preceding instruments, and, with this greater advantage besides, that they can all be effected with one hand applied to the arm *f*.

A smaller lens is supplied with some microscopes for the purpose of further condensing the rays of the larger condenser, or of rendering the converging rays of the larger one parallel, whereby a greater field of view is illuminated, a plan very useful where dissections are being carried on under a lens. One of these instruments is represented by fig. 61. The method of mounting the small lens is somewhat similar to that last described, and it may be fixed into some part of the microscope stand, as seen in Plate 2 at *dd*, or else it may be

provided with a support of its own, as adopted by Messrs. Powell and Lealand. If necessary both the large and small

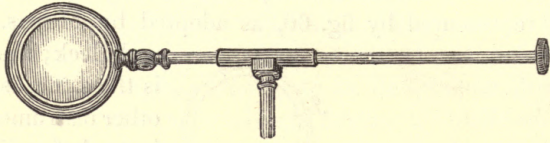

Fig. 61.

condenser may be mounted on the same stem and foot as represented in fig. 62, a plan adopted by Mr. Leonard, by which means the two may be used either separately or com-

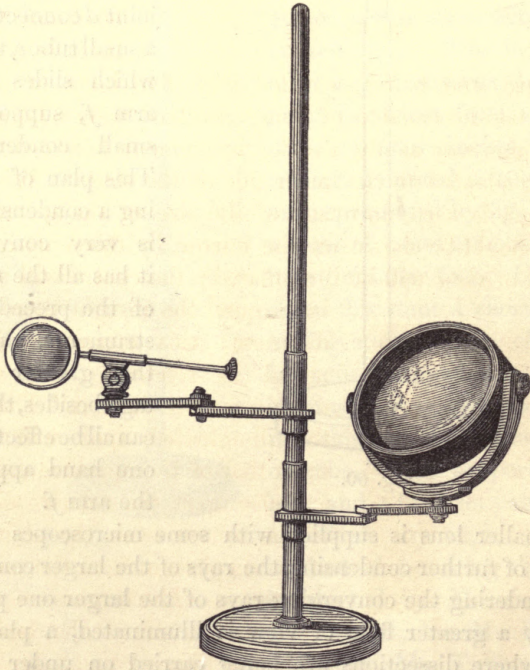

Fig. 62.

bined. All the different methods of employing the two forms of condensers will be fully explained in the chapters devoted to the illumination of opaque and transparent objects.

Messrs. Powell and Lealand supply, with some of their instruments, a diaphragm of the form represented by fig. 63,

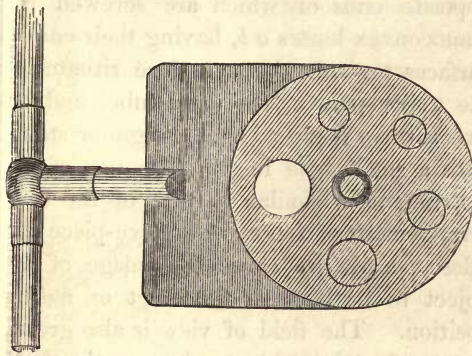

Fig. 63.

which, when used, is adapted to the stand of the large condensing lens, and is placed in front of the lamp at about eight inches distant from the mirror: it consists of two plates of thin sheet iron, blackened; one of these is of a circular figure, and being provided with five holes of different sizes, is besides capable of being revolved upon a larger plate in the same way as the smaller instrument before described, as being adapted to the under side of the stage. When this diaphragm is used, an image of the size of the aperture employed should be shown on the mirror, by this only a part of the field of view will be illuminated; the centre will be light, but around the margin there will be darkness; this oftentimes is very useful in rendering very delicate markings more distinct. The size of the illuminated spot will depend upon that of the aperture employed, and also upon the relative distances of the mirror from the object, and of the diaphragm from the mirror.

When this diaphragm is used, an image of the size of the aperture employed should be shown on the mirror, by this only a part of the field of view will be illuminated; the centre will be light, but around the margin there will be darkness; this oftentimes is very useful in rendering very delicate markings more distinct. The size of the illuminated spot will depend upon that of the aperture employed, and also upon the relative distances of the mirror from the object, and of the diaphragm from the mirror.

Erector.—Those microscopes supplied with a draw-tube, before described in Plates 2 and 3, are capable of having adapted to them the erector or erecting eye-piece; this is represented by fig. 64, as being screwed into the lower end of the draw-tube;

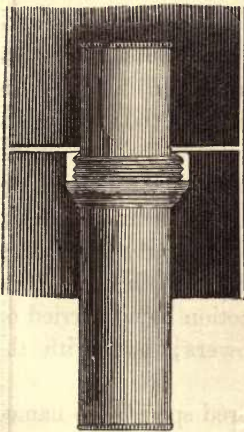

Fig. 64.

it consists of a piece of brass tube, three inches in length, and five-eighths of an inch in diameter, as seen in fig. 65 ; into the

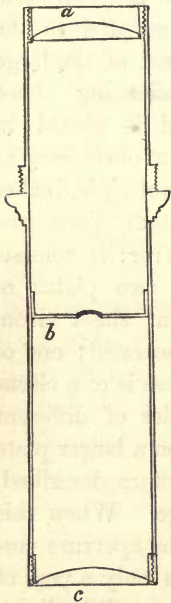

Fig. 65.

opposite ends of which are screwed two planoconvex lenses *a b*, having their convex surfaces towards the eye-piece situated in the upper part of the draw-tube, and between them is placed a diaphragm or stop *b*, with a small hole in it. The use of this instrument is similar to that of the same arrangement of lenses in the eye-piece of a telescope, viz., to cause the image of any object to be seen in the erect or natural position. The field of view is also greatly increased, and an object as long as the three-fourths of an inch can be taken in at once with the erector and a two-inch object-glass ; by pulling out the draw-tube, and therefore increasing the distance between the erector itself and the object-glass, the magnifying power of the instrument is increased, and by pushing it in again the power is diminished ; so that a microscope with a two inch object-glass and the erector can be made to take in as much of a rule as three-fourths of an inch in length when the draw-tube is only slightly pulled out ; and when the tube is pulled out to its fullest extent, it will magnify the divisions on the rule so much, that one-sixth of the same object alone will fill the whole field of view.

The erector was first applied to the compound microscope, represented by fig. 21, by Mr. Lister ; it is extremely useful for taking in large objects, but more particularly for dissecting, as heretofore the inversion of the object by the compound microscope, entirely prevented any dissection being carried on under any of the low magnifying powers ; but, with the erector, it can be done very readily.

Lieberkuhns.—These are concave silvered specula, so named from their illustrious inventor ; they are attached to all the object-glasses, from the two inch to the one-fourth, in the

manner represented by fig. 66, where *a* exhibits the lower part of the compound body, *b* the object-glass, over which is

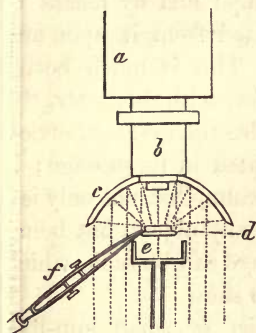

Fig. 66.

slid a tube having the Lieberkuhn *c* attached to it; the rays of light reflected from the mirror, either in parallel or converging lines, are brought into a focus upon an object *d*, placed between it and the mirror. The object may either be mounted on glass in the usual manner, or else held in the forceps *f*; and when too small to fill up the entire field of view, or when transparent, it is necessary to place behind it the dark well *e*. Each Lieberkuhn being

mounted on a short piece of tube, can be slid up and down on the outside of the object-glass, so that the maximum of illumination may be readily obtained. In all the higher powers the end of each object-glass is turned small, and passes through the aperture in the centre of the Lieberkuhn; but in the lower powers, where a great amount of reflecting surface would be lost on account of the large size of the glasses employed if this plan were adopted, the aperture in the centre of the Lieberkuhn is just large enough to admit as many rays as will fill the field of view, and no more.

Side Reflector.—As a substitute for the Lieberkuhn, Mr. Ross supplies with his microscopes what he terms a side-illuminator or reflector: it consists of a concave speculum of a rectangular figure, highly polished and mounted on a jointed arm, as represented by fig. 67: it, like the small condensing

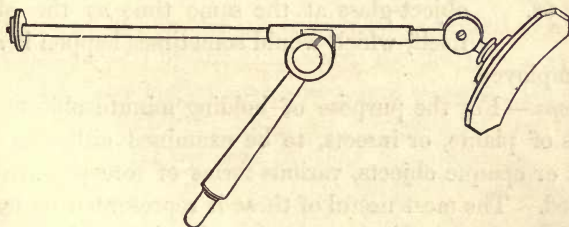

Fig. 67.

lens, is attached to some immovable part of the instrument, and parallel rays of light from the lamp are thrown upon it by the bull's-eye placed close to the lamp; and by means of the jointed arm, the light may be reflected from it upon any object, however large, on the stage. This is much better than a Lieberkuhn for most purposes; for, with the latter, the objects cannot exceed a certain size, else the greater portion of light from the mirror will be intercepted in its passage; it has also this advantage over the Lieberkuhn, that not only is a greater amount of light condensed upon any object, but being thrown obliquely, many minute markings can be seen, which the vertically reflected light is unable to show.

Dark Stops or Wells.—These consist of small cup-like pieces of brass, mounted on wire stems or supports; the shapes generally employed are represented by fig. 68. They are



Fig. 68.

used with the Lieberkuhns, and three different sizes are usually supplied with the best microscopes, the largest being always employed with the lowest power object-glasses. Their use is to cut off all the rays of light that would otherwise pass into the object-glass, hence they are required in all cases where the object to be viewed is transparent. The long stem fits into a small arm attached to the under surface of the stage, and capable of being moved into the centre of the aperture therein, and by it the well at the top can be raised up so high, as nearly to touch the object itself; the cup-shaped form is used, in order that the bottom and edges may not be within the focus of the object-glass at the same time as the object-itself, which would sometimes happen if a disc

were employed.

Forceps.—For the purpose of holding minute objects, such as parts of plants, or insects, to be examined either as transparent or opaque objects, various forms of forceps have been contrived. The most useful of these is represented by fig. 69. It consists of a piece of steel wire, about three inches long,

which slides through a small tube, connected to a stout pin by means of a cradle-joint; to one end of the wire is attached a

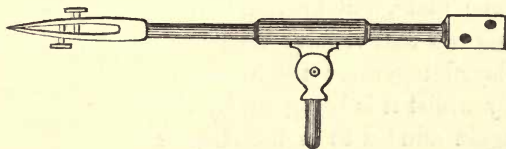

Fig. 69.

pair of blades, fitting closely together by their own elasticity, but which, for the reception of any object, may be separated by pressing the two projecting studs; to the opposite end of the wire is adapted a small brass cup, filled with cork, into which pins, passed through discs of cork, cardboard, or other material having objects mounted on them, may be stuck; or, if preferred, instead of the cork, a pair of blades, fitting accurately together, may be employed, with small notches in each to receive the pins. With all the old microscopes, one end of the wire carrying the forceps was made pointed, and to it was adapted a small cylindrical piece of ivory, having one of its ends white and the other black, on these surfaces the objects for examination were laid. Mr. Ross and Mr. Smith sometimes supply a pair of three-pronged forceps; the prongs are made of steel wire, they are curved and pointed at one end, and by means of a sliding ring can be opened or closed. An instrument of this kind was in use as long ago as 1787, and is figured in the work of the younger Adams, published in that year. The method of using these different forms of forceps is extremely simple: the object-plate of the stage of the microscope is supplied with one or more holes, into which the pin of the forceps may fit; on this pin they may be turned in a horizontal direction, and by the joint above the pin they may also be inclined at any angle; and when once adjusted, the stage movements will suffice to bring all the parts of the object which they hold into the field of view in succession. With some of the foreign microscopes are supplied other forms of forceps, constructed after the plan of our spring pliers or

scissors; one of these, with flat lips for holding objects, being secured to the object-plate of the stage, and another, either held in the hand, or else similarly attached to the opposite side of the same plate, but provided with cutting edges like the pair of scissors said to have been invented by Smammerdam, are employed together; the former of these retains the subject firmly whilst it is being cut by the latter. These forceps will be again alluded to in the chapter devoted to dissecting instruments.

Animalcule Cages.—Instruments known by the name of “live boxes” have been in use for many years, and were supplied with all the old microscopes; they consisted of a brass cell, from three-quarters to one-inch-and-a-quarter in diameter, into which a planoconcave glass was made to drop; upon the concave side the insect was placed for examination, and a flat piece of glass of the same size, but fastened into the bottom of another cell, could be screwed down upon the insect, so as to prevent its movement; this instrument has now been entirely superseded by more convenient forms, and amongst them may be mentioned the animalcule cage of Mr. Tulley, and the capillary tablets of Mr. Varley. The animalcule cage supplied with the compound achromatic microscope of the late Mr. Tulley, is represented by fig. 70: it consists of a plate



Fig .70.

of brass, from three to four inches in length; to the middle of this was attached a piece of brass tube, about three-quarters of an inch in diameter; into the top of which was fastened a plate of thick glass, over this tube another short one, having a cover of thin glass cemented to a rim at its top, is made to slide; this last tube is sufficiently short to allow the thin glass cover and the plate in the fixed tube to be brought into contact. The drop of water containing the animalcules to be examined, is put upon the piece of plate-glass, which may be termed the object-plate; and the tube containing the thin glass cover is then to be slid down carefully, so that the drop may be flattened out; in order to

other short one, having a cover of thin glass cemented to a rim at its top, is made to slide; this last tube is sufficiently short to allow the thin glass cover and the plate in the fixed tube to be brought into contact. The drop of water containing the animalcules to be examined, is put upon the piece of plate-glass, which may be termed the object-plate; and the tube containing the thin glass cover is then to be slid down carefully, so that the drop may be flattened out; in order to

allow the contained air to escape in the sliding down of the cover, a small hole is drilled in the top; this may be subsequently closed with sealing-wax, if it be required to preserve the fluid for future examination.

Mr. Varley, in the year 1831, greatly improved this form of instrument, and gave to it the name of capillary tablet or cage, in a paper published in the forty-eighth volume of the *Transactions of the Society of Arts*. This great improvement consisted in making a channel all round the object-plate, so that the fluid and the animalcules in it were retained at the top of the object-plate only by capillary attraction, and will bear turning about in all directions without leaving the top, provided it be not suddenly shaken. The cover also was made to screw down upon the object-plate, and not to slide as in the previously described instrument; but in practice it has been found most convenient to adopt the sliding tube, as the act of screwing sometimes deranges the objects. The plate of brass to which the tube supporting the tablet and cover is attached, was of a circular figure, slightly flattened on two opposite sides, for convenience of package, as several of them could be contained in a small cylindrical case. The improvement made by Mr. Varley, in the object-plate or tablet, is now adopted by all our first-rate microscope makers, but with some few slight modifications; one of these instruments, as constructed at the present time, is represented by fig. 71 in elevation, and

Fig. 71.

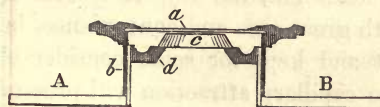
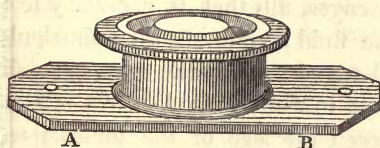

Fig. 72.

in section by fig. 72.

A B in both figures exhibits the flat plate of brass to which the short tube, carrying the object-plate, or tablet, is fixed; *d*, fig. 72, exhibits the piece of brass into which the tablet *c* is fastened, *b* the tubular part of the cover, into the rim of which the thin plate of

glass *a* is cemented. This thin glass cover is often either

broken or becomes uncemented; to remedy the inconvenience of re-cementing, Mr. Powell adopts a very excellent plan, by which a new cover can be adapted with little trouble: the tubular top is provided with a screw, upon the edge of which the cover of thin glass or mica is laid; over this a cap screws which keeps the cover firm. Fig. 73 represents the tubular top, with its screw cap, and fig. 74 a section of the entire

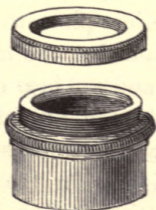

Fig. 73.

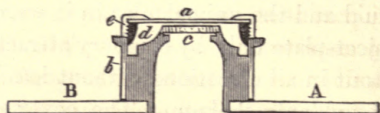

Fig. 74.

instrument, A B being the flat support, *c* the object-plate or tablet, *d* the channel around the same, *b* the tubular top with its screw-cap *e*, holding down the thin glass cover *a*. When the glass cover is of tolerably stout glass, these cages, besides being only employed for animalcules, may be used for compressing such objects as are soft, but still too opaque to be seen through. When these are moderately compressed, their structure is readily made out; but an instrument constructed for this purpose especially, and known as the compressorium, will be presently described.

To use these animalcule cages, all that is necessary is to place a small quantity of the fluid containing the animalcules upon the object-plate or tablet, and to slide the cover carefully until the drop is flattened out to the required degree of thinness; this should never exceed the size of the tablet itself. When the drop of fluid is made flat, the objects it contains may not only be viewed with great ease and convenience, but they may be carried about and kept for some considerable time under observation; the capillary attraction will preserve the fluid between the two glasses, and no shaking or turning that is not sudden will injure them in the least. When more fluid than is necessary is placed upon the bottom glass, the

excess will escape into the channel, and, in all probability, most of the animalcules with it; in this case it is by far the best plan to wipe away all the fluid from the bottom-plate and the channel, and make the latter and the under surface of the thin glass cover perfectly dry before another drop is put upon the bottom glass, otherwise the channel, when once made wet, will attract the fluid again. In the animalcule cages, or live boxes, manufactured by Mr. Pritchard, the bottom plate of glass is ruled with fine lines, the one-hundredth part of an inch or less apart: this serves as a micrometer. When used dry the lines are visible, but when fluid is interposed, they can not only hardly be seen, but all measurements made by such micrometers are manifestly incorrect with objects of any degree of thickness, as their true outline is not in focus at the same time as the lines of the micrometer; this point will be particularly dwelt upon in the chapter devoted to the measurement of objects, but in this place it merely requires to be noticed in connection with the instrument to which it is applied.

Fishing Tubes for Animalcules.—These consist of tubes of glass, about nine inches in length, open at both ends, and from one-eighth to one-fourth of an inch in diameter; the ends should be nicely rounded off in the flame of the blow-pipe; some of them may be straight, as in A, fig. 75, whilst others should be drawn out to a fine point as C, or curved as in B D; in short they may be made of either of the shapes represented in fig. 75, all of which have been found equally desirable. Mr. Varley, to whom we are indebted for this valuable invention, describes the method of using them in vol. forty-eight of the *Transactions of the Society of Arts*. Supposing the animalcules that are about to be examined to be contained in a phial or glass jar, as in fig. 76; having observed where they are most numerous, either with the naked eye, if they are large, or with a pocket magnifier or the watchmaker's lens, described at page 50; if they are small, either of the glass tubes, having one end previously closed by the thumb or fore-finger wetted for the purpose, is introduced into the phial in the manner represented by the figure; this prevents the water

from entering the tube, and when the end is near to the object which it is wished to obtain, the finger is to be quickly

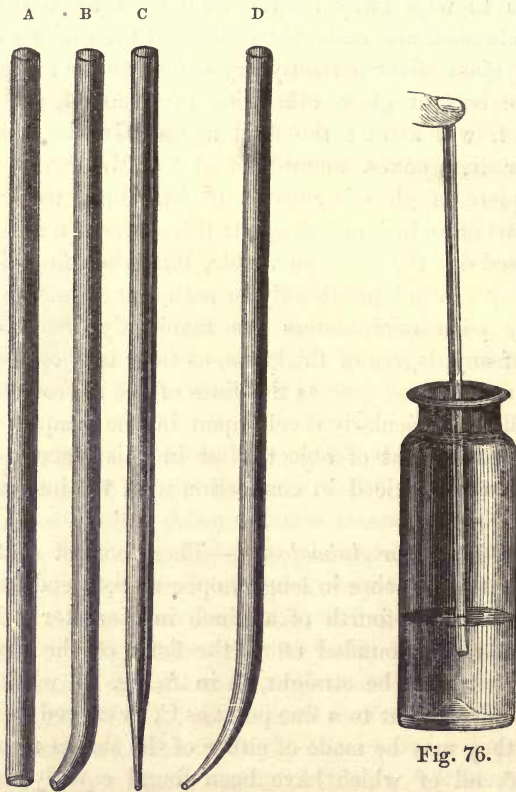

Fig. 75.

Fig. 76.

removed and as quickly replaced; the moment the finger is taken off, the atmospheric pressure will force the water, and with it, in all probability, the desired objects up the tube; when the finger has been replaced, the tube containing the fluid may be withdrawn from the phial, and as the tube is almost certain to contain much more fluid than is requisite, Mr. Varley adopts the following plan for getting rid of the excess.

Being provided with some watch glasses and some pieces of plane glass, if the tube should contain more fluid than is neces-

sary, the entire quantity must be dropped into a watch glass, which spreads it, and the insect may be again caught by putting the tube over it, when a small quantity of fluid is sure to run in by capillary attraction; this small quantity is to be placed upon the tablet; but should there be still too much for the tablet, if it be touched with the tube again, it will be diminished; and should the object be wanting, the fluid must be wiped off, and the operation repeated until we are satisfied of its presence.

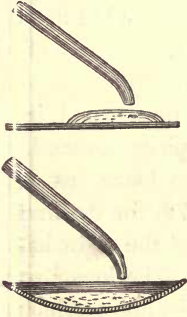

Fig. 77.

If we wish to place several individuals together on the tablet, it is necessary that each should be taken up with the smallest amount of water; to effect this Mr. Varley suggests that the tube should be emptied on a slip of glass, in separate drops, as in fig. 77, and with one of the capillary tubes, but little larger than enough to catch them, they may be lifted out one by one, and be placed on the tablet. Generally speaking, it is necessary to add a small quantity of vegetable matter to animalcules to keep them alive; and as many species of them are found on *confervæ* and duck-weed, some instrument is required to take small portions of these plants out of the jar in which they are growing; for this purpose Mr. Varley has contrived the forceps represented by fig. 78:

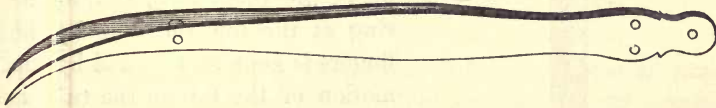

Fig. 78.

they are made of brass, and the points are a little curved; to keep them accurately together, they are provided with a hole and steady pin. This instrument, being thin and easily closed, serves very well to put into a phial and take out small portions of vegetable matter; but when jars, such as those in which *chara* or *vallisneria* are kept, are deep, then the long forceps,

the invention of my late brother, Mr. Edwin Quekett, and represented by fig. 79, will be found extremely useful. They

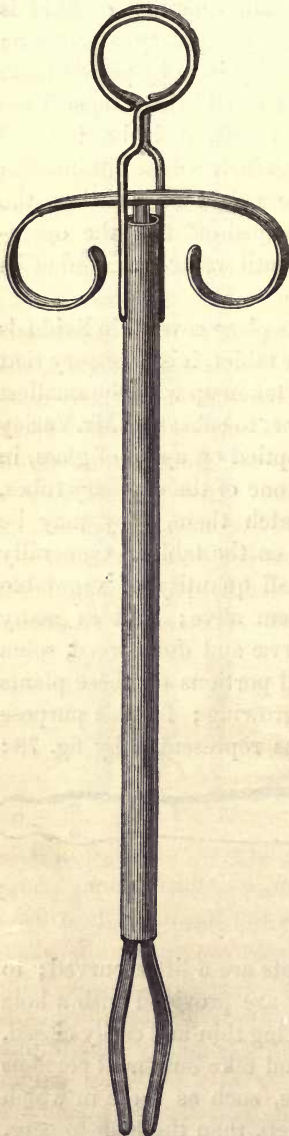

Fig. 79.

should be made either of brass or German silver, and may be of any length, from nine inches upwards. The central part is a piece of wire about one-eighth of an inch in diameter; its upper end is fastened to a flat piece of metal, bent round into two loops, as represented by fig. 79, for the first and second finger of the right hand to be placed in. The lower part of the wire is split, and having been well hammered to make it springy, is bent into the form of a pair of forceps. On the outside of the wire is a piece of tube about one-fourth of an inch in diameter, and shorter than the wire; to its upper part is soldered a piece of smaller wire, bent into the form of a ring. The use of this instrument must be obvious from the figure; the first and second finger of the right hand being placed in the two loops, the thumb is put into the ring at the top, the wire by the fingers is kept steady, and by the motion of the thumb the tube is raised or depressed; when the tube is raised, the blades of the forceps being springy, open readily, and when the thumb is depressed, the blades are as easily closed.

This pair of forceps will be found very useful for taking hold of small pieces of valisneria and chara, and

a pair of blades may be applied to them for the purpose of cutting off portions of these plants close down to the roots, even in tall jars that are far too small to admit of the introduction of the hand.

COMPRESSORIUM.

THE compressorium is an instrument by which objects may be gradually compressed between two parallel plates of glass. The pressure may be applied whilst the object is being examined with the microscope, and may be kept up at will, so that the alteration which it assumes, as the pressure is being applied, can be observed with facility; it is extremely useful for crushing or compressing such objects as are so thick that the light cannot readily be transmitted through them, or for making flat others whose elasticity is sufficient to raise up the thin cover when they are placed between glasses to be viewed in the ordinary way. There are many kinds in use, some of foreign, others of home invention. The most simple, and the one in which the power employed cannot exceed the force of two spiral springs, is made by Mr. Smith, after a plan of Mr. Lister's, and is represented by fig. 80. It consists of a bottom

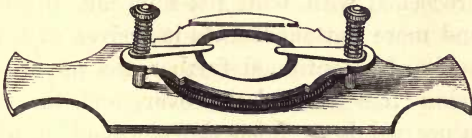

Fig. 80.

plate of brass which has rising from its centre a piece of tube having on its outside a short screw, on which works a large circular nut, with a milled head; to the inside of the tube a circular piece of plate-glass is fixed, projecting slightly above its edges; this may be called the object-plate; two small upright rods, fastened into the bottom plate, are provided with spiral springs, their tops being surmounted by small nuts, which keep the springs in place. A plate of brass, with a hole in it larger than the object-plate, is made to slide up and down the rods in a state of parallelism, by means of the large

circular nut; and two wedge-shaped tongues of watch spring are placed between the spiral springs and this plate. These tongue-shaped springs are capable of being moved round upon the rods, and are for the purpose of communicating pressure to a thin plate of glass resting upon the plate, which is prevented from sliding off by a raised edge. The plate carrying the thin glass cover is capable of being raised or depressed at will, by means of the circular nut. It will be seen, that when the plate carrying the thin glass cover is raised up as high as it will go by the milled nut, the cover will not touch the lower plate of glass; when this is the case, the instrument is ready for the reception of an object. The ends of the little steel springs must be lifted up by the finger-nail or some other thin instrument, and then rotated so far outwards as to get them clear of the cover. The cover being lifted off, the object is to be placed upon the bottom plate with as much fluid as necessary, and the cover being replaced, the springs may be lifted up and turned back to their original position. If now the nut be screwed down, the spiral springs will cause the plate to follow the nut, and when the nut has been turned far enough to allow the cover to come in contact either with the object or the fluid, it will be noticed that as the screwing is being proceeded with, both the fluid and the object will be more and more flattened, until it arrives at a maximum. If the screwing be continued further, the nut will leave the plate carrying the thin glass cover, and the cover itself will remain pressed down upon the object-plate with all the force exerted by the spiral and by the tongue-shaped springs.

Mr. Ross has improved upon the compressorium of Mr. Lister, by making the plate carrying the thin glass cover, square, and by adding to it two other pillars, making four in all; upon two of these, situated at opposite corners, strong spiral steel springs are wound, and to the two others are applied finger-shaped pieces of German silver, to keep down the thin glass cover. The action of the large nut is the same as in Mr. Lister's instrument, but the pressure exerted by the springs is more powerful than in it. The finger-shaped pieces

of German silver yielding but slightly, and the steel springs being much stronger than the brass ones, the power of compression is greatly increased.

When a more powerful compressorium is required, the form represented by fig. 81 is highly useful. It consists of a



Fig. 81.

plate of brass, three or more inches long and one-and-a-half broad, having in its middle a circular piece of plate-glass for an object-holder; this is slightly raised above the metal plate, at one end of the latter is a circular piece of brass, having attached to it another piece of brass, carrying an arm capable of being moved up and down by means of a screw at one end, whilst at the other is a semicircle supporting by screws a ring of metal, to the under side of which a piece of thin glass is cemented; the semicircle is made to turn upon the arm, and the arm and all that is attached to it is capable of being turned upon the bottom plate.

The use of this instrument is obvious: if we wish to compress any substance, we must first, by means of the screw, elevate the opposite end of the arm from the object-plate; the arm, with all its appurtenances, is then to be turned away from the object-plate, and the object being placed on the plate with a requisite quantity of fluid, the arm is then to be brought into its proper place again, and by means of the screw, the metal ring with the thin glass cover can be made to exert as much pressure as the thin glass cover will stand without breaking. Messrs. Powell and Lealand have lately constructed a much stronger instrument than that represented by fig. 81, and have made their object-plate of a thick piece of parallel glass, raised as much as the one-eighth of an inch above the bottom plate, so that it can be cleaned without much trouble; and the ring containing the glass cover is made

much stouter, and fits accurately upon the raised object-plate.

Troughs for Chara and Polyps.—These consist of two plates of glass, cemented together with strips of the same material, or of metal between them, to form the sides of the trough; one of these, as described by Mr. Varley, in the forty-eighth vol. of the *Transactions of the Society of Arts*, is represented by fig. 82. *c* is a bottom-plate of stout glass, upon

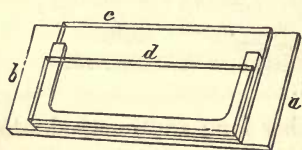

Fig. 82.

which is cemented with pitch and bee's-wax a thin cover *d*, with slips of glass between it and the bottom-plate, to form the sides. The cover *d* is not so broad as the plate *c*, in order that a slip of chara may be more readily placed in the

trough, as it can be first laid upon *c*, and then gradually be slid down between it and the cover *d*. In order to render the trough more manageable, it may be cemented to a larger bottom-plate *a b*, by Canada balsam; but it will be found far more advantageous if the bottom-plate itself be as large and as broad as *a b*, and if the cover *d* be cemented to it and not to another plate, as then two extra surfaces will be dispensed with. Mr. Varley informs me that a piece of wire bent into the shape of the slips of glass represented in the figure, and covered thickly with a cement composed of bee's-wax and pitch, will form an excellent substitute for the slips, and look very neat; the cements of Canada balsam or sealing wax are much too brittle to last long, as a sudden jar will cause them to give way. Messrs. Smith and Beck supply with their microscopes a larger and much thicker trough for chara and polyps, as represented by fig. 83; the front is composed of much thinner glass than the back, and the method adopted of confining objects near to the front varies according to circumstances. One of the most convenient plans, is to place in the trough a piece of glass that will stand across it diagonally, as represented by fig. 83, and if the object be heavier than water it will sink, until it is stopped by the diagonal plate.

At other times, when chara is being observed, the diagonal plate may be made to press it close to the front by means of thin strips of glass, a wedge of glass or cork, or even a folded spring. When either of these instruments is used, it may perhaps be necessary to remind the reader that the microscope must be so far inclined as to be nearly horizontal. Messrs. Smith and Beck adapt to the object-plate of their large microscopes a strong steel pin, upon which a spring-holder is made to fit; this serves to keep the trough firm and to prevent its falling off, even when the microscope is perfectly horizontal. This form of trough proved very serviceable to Mr. Lister, in 1834, during his investigations into the structure of some of the higher orders of polyps, and will be found of



Fig. 83.

very great value to those who devote some attention to this most interesting branch of scientific inquiry.

Frog-Plate.—This consists of a plate of brass *a a*, about six inches in length, and two-and-a-half in breadth, and either of the shape represented by fig. 84, or of the same breadth

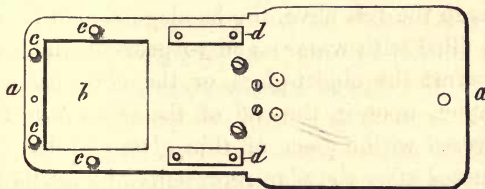

Fig. 84.

throughout; the former plan is adopted by Mr. Ross, the latter by Mr. Powell. At one end it is provided with a plate of glass to cover either a square or round aperture *b*, made in the brass, which serves for laying the frog's foot on. Around this aperture are placed four or more studs *c c*, for the purpose of securing the threads by which the web of the foot is kept open; in Mr. Powell's plate, a series of small holes answer the same purpose. Mr. Powell also secures his plate

to a large stage by means of a spring clip, whilst that represented by fig. 84 is provided with a slightly conical brass pin, which is made to fit into one of the holes of the object-plate, and on which it is capable of being revolved. At the base of the pin there is a small strip of brass for securing either the tape or string attached to the bag containing the frog. Some persons employ a piece of cork or soft wood in preference to the brass plate; this has many advantages, and will be again alluded to in the chapter devoted to the most approved methods of exhibiting the circulation of the blood in the lower animals.

Fish Troughs.—From the time of Leeuwenhoek to within the last few years, all microscopes of any importance were supplied either with a glass tube or a fish-pan for holding small eels or minnows, in order that the circulation in their transparent fins might be seen: these have all given place to the frog-plate just described; but when it is required to exhibit the circulation in the tail of a small fish, a glass cell or trough will be found very convenient. This should be a little deeper and longer than the fish itself, and the fish should be secured in it by a broad tape or bandage, wound loosely round the middle third of the body, or even carried down to within a very short distance of the commencement of the tail. In order to keep the fish alive, the bandage should be wetted or the trough filled with water; and to prevent the flapping of the tail against the object-glass, or the condensation of the aqueous vapour upon it, the end of the cell where the tail is may be covered with a piece of thin glass. I have found a cell constructed after the plan represented by fig. 85 to answer



Fig. 85.

uncommonly well. *a* represents a plate of glass about three inches in length, *b* a glass cell cemented to it, *c c'* two

pieces of glass to raise the bottom-plate above the level of the stage, in order that the bandage may lie in a cavity and not prevent the trough from resting perfectly horizontal. Some other advantages in this little apparatus will be again alluded to.

Phial Holder.—This instrument, the contrivance of Mr. Varley, is represented in elevation by fig. 86, and in section by fig. 87. It consists of a tube of brass about an inch-and-

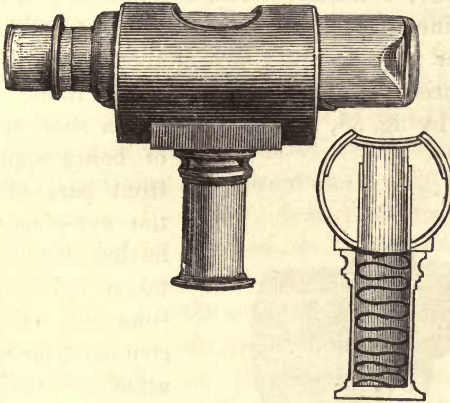

Fig. 86.

Fig. 87.

a-half in diameter, and two or more inches in length, having an oval hole cut out at the top, and a smaller tube attached to the lower side, immediately opposite the hole; within this last slides a still smaller tube, provided in its interior with stops like those in the dark chamber, fig. 50, and a curved plate of brass at its top; it is capable of being moved up and down, but a spiral spring always presses it towards the hole in the large tube. The use of this apparatus is obvious: a smooth wide mouth phial, having chara or other water plants growing in it, is to be introduced into the large tube in the manner represented by fig. 86, the small spring tube having been first pushed down, the phial is then kept firmly in contact with the upper surface of the outer tube, but not so firm but that it may be either turned round or slid in or out. The small outer tube, besides containing the dark chamber, serves the purpose of attaching the whole of the apparatus to the stage of the microscope. In order that the phial may move very smoothly, all the parts fitting against it should be lined with black cloth, and all the parts of this apparatus, as well as of all others through which light has to pass, should be covered

with some black pigment to absorb those rays of light which if reflected would materially interfere with correct definition.

Camera Lucida.—This instrument, invented by Dr. Wollaston in 1807, is a most valuable addition to a microscope, both for delineating minute structures, and for obtaining with a micrometer very accurate measurements. It consists of a four-sided prism of glass, set in a brass frame or case, as represented by fig. 88, and by means of a short tube capable

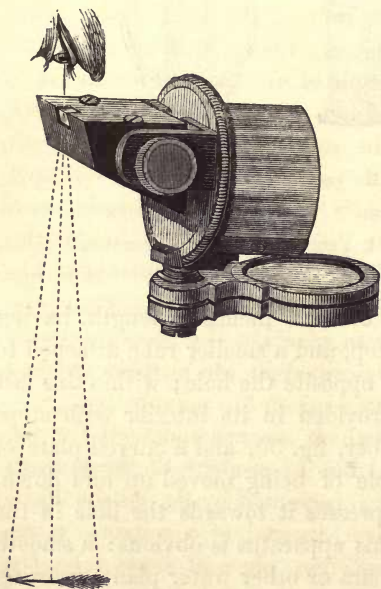

Fig. 88.

of being applied to the front part of either of the eye-pieces, its cap having been previously taken off. Mr. Ross, from one of whose instruments fig. 88 is copied, attaches the prism, by two short supports, to a circular piece of brass at the end of the tube; on this it can be slightly rotated, whilst the prism itself can also be turned up or down; by means of two screws with milled heads; so arranged, the camera may be adapted to the eye-piece, the microscope having been previously placed in a horizontal position, if

the light be then reflected up through the compound body, an eye placed over the square hole in the frame of the prism will see the image of any object on the stage upon a sheet of white paper placed on the table immediately below it. But should it happen that the whole of the field of view is not well illuminated, then, either by revolving the circular plate or turning the prism upon the screws, the desired object will be effected. The chief difficulty in the use of this instrument is for the artist to be able to see at one and the

same time the pencil and the image; to facilitate this in some measure, Mr. Ross places either one or two lenses below the prism, in order that the rays from the paper and pencil may diverge at the same angle as those received from the prism, whereby both object and pencil may be seen with the same degree of distinctness.

Messrs. Powell and Lealand supply with their microscopes a small highly polished steel mirror, fixed at an angle of forty-five degrees, and placed in the focus of the eye-piece, where it is held by a spring clip, as represented by fig. 89. This

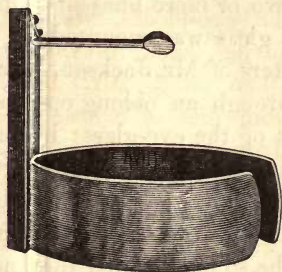

Fig. 89.

mirror, being smaller than the pupil of the eye, allows the rays of light from the paper to enter the eye around it, so that both the paper and the image reflected on it by the mirror may be seen at the same time and under the same angle; this instrument has some few advantages over the camera of Dr. Wollaston, and with

it will be more especially described in the chapter devoted to the uses of the camera in drawing and in micrometry.

Prism.—M. Dujardin, to whom we are indebted for the achromatic condenser, found that to produce the best effects a prism of glass of the form represented by fig. 90 should be

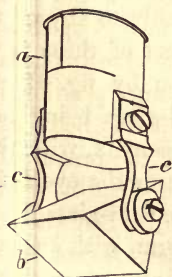

Fig. 90.

used with it, instead of a mirror. *a* represents a short piece of brass tube, *b* a glass prism connected by screws to the tube *a* by two supports *c*. The tube is made to slide upon the end of the condenser, and to turn upon it in such a manner that, in whatever position the lamp or white cloud may be, the prism may be adjusted to it; the revolution of the prism being performed upon the screws, whose extremities are conical and fit into corresponding depressions in the side of the

prism. This instrument has some few advantages over the

plane mirror: the quantity of light is greater, and all test objects in which delicate markings exist may be shown to the best advantage; in consequence of some of the rays being transmitted whilst others are reflected, the shadow of the markings will be more strongly exhibited.

Indicator.—For the purpose of pointing out to those who are uninitiated in microscopic research any particular part of an object that may be in the field of view, various contrivances have been had recourse to; but the author, who has often found the want of some kind of indicator, first employed a slip of glass, on which were ruled two or more lines at right angles to each other. This slip of glass was mounted in a frame of brass, and like the micrometers of Mr. Jackson, hereafter to be described, was slid in through an oblong opening in one of the eye-pieces in the focus of the eye-glass; by the ruled glass the field of view was divided into four compartments, and any object therein could be so arranged by the adjustable stage, that it might be in the first, second, or any other compartment, or even might be so placed, that the lines at their intersection may pass through it; this plan was very convenient and answered uncommonly well with the lower powers; but with the higher, the definition was not good, in consequence of the introduction of the ruled glass between the eye and field lens, the author was, therefore, led to the construction of the indicator, represented by fig. 91, which is

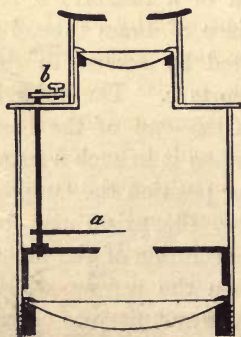

Fig. 91.

a very simple apparatus, and can be applied very readily to any of the eye-pieces, the lowest of these is represented in section by fig. 91, the eye-glass and field-glass being both shown to be planoconvex, with their plane surfaces towards the eye. Immediately above the field-glass is seen the stop or diaphragm, with an opening in it about half-an-inch in diameter; between the diaphragm and the upper plate of the eye-piece, a thin spindle of wire is placed, having a

very delicate hand, like that of a watch, attached to it in the focus of the eye-glass. The spindle is provided at its upper part with a small handle, for the purpose of turning it and the hand just one-fourth part of a circle. When the indicator is not required, the hand is obscured from the field of view by being turned against the side of the tube, away from the aperture in the stop; but when required for use, it is turned over the aperture, and then the field of view appears as is shown by fig. 92. The hand may be turned into the centre of the



Fig. 92.

field, and any object in particular that is required to be indicated can be brought by the stage movements immediately opposite to the end of the hand. The form of hand first employed was one with a hole near its free extremity; but it was found that the light was decomposed around the inner margins of the ring, this led to the adoption of the form represented by fig. 92, as being less liable

to interfere with direct definition, and also readily made out of a piece of small flat steel wire.

Bonnet or Hood for the Compound Body.—For the purposes of drawing, or when an object has to be carefully examined for a long time by lamp-light, in order to screen the eye as much as possible from all extra illumination, an apparatus, termed the hood or bonnet, has been contrived by Mr. Lister. It consists of a shade made of four or more pieces, either of cardboard or pasteboard, painted black, or else covered with black cloth or velvet: it is of an oblong figure, and the centre-piece fits upon the eye-piece or upon the end of the compound body close to it, whilst the remaining three pieces turn up to form the sides; sometimes there is a place cut out for the nose to fit into. When this instrument is used, no light or heat can come near the eyes but that reflected through the compound body by the mirror; all glare, consequently, is taken away. Mr. Lister's hood is very portable, the sides fold down upon the centre-piece, and then it occupies a very small

compass. Mr. Leonard has constructed a much more substantial hood of millboard, covered with leather; a front view of this apparatus is represented as applied to the microscope in fig. 93, and a back view in fig. 94.

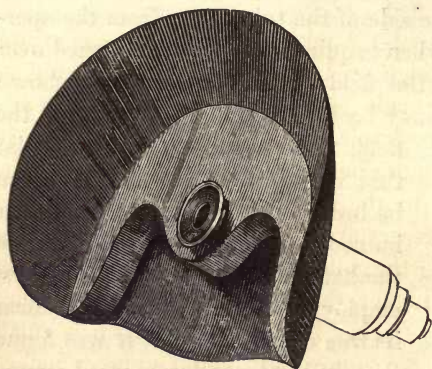

Fig. 93.

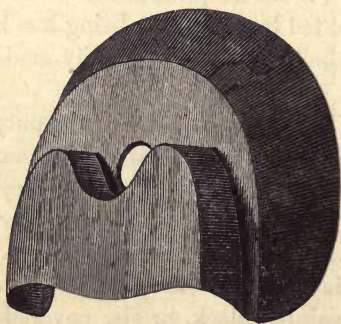

Fig. 94

The forehead is surrounded by the circular top, and two depressions are made in it for the nose, one on either side of the compound body, in order that the observer may use either his right or his left eye. The back of the recesses for the nose must be made of black silk or stuff, but not closed at the bottom to confine the breath, which would make the eye-glass dim.

Goniometer. — A very valuable instrument for measuring the angles of minute crystals, known as the goniometer, the invention of Dr. Leeson, is capable of being applied to the microscope, and is furnished

by Messrs. Smith and Beck for this purpose. As some little time is required before an observer can get into the way of using it with facility, it has been deemed best to give a lengthened description of it in a chapter devoted to the subject.

The various modes of employing the knives, forceps, dissecting and all other instruments, supplied with the best microscopes, will be considered in full in other parts of the work.

CHAPTER IV.

THE LAMP.

THE lamp generally used for microscopic purposes is of the kind called the Cambridge or University Reading Lamp, as shown by fig. 95 ; it is made of various shapes and sizes, and consists of a circular reservoir about four or five inches in diameter, and two or more inches in depth, having the tube which conveys the oil to the wick inserted into one side of the lower part of the reservoir ; the tubular part containing the wick and supporting the gallery or chimney holder, termed the burner, is a little higher than the top of the reservoir ;

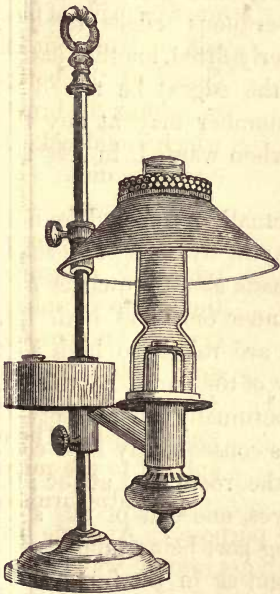

Fig. 95.

this last is mounted on a small square stem, about eighteen inches high, rising from a heavy metal stand or base, and passing through the middle of the reservoir, which is made to slip up and down upon the stem, and is fixed at any height by means of a tightening screw ; the burner is an argand one, and the diameter of the wick about three-quarters of an inch ; at the bottom of the burner is screwed a little cup for catching the superfluous oil. Upon the same square stem supporting the reservoir may be adapted a hood or shade of a conical figure ; this, like the reservoir, slides up and down the stem, and may be fixed at any required height ; it is generally made of metal, and is of a dark colour on

the outside, and in the inside is painted white, to throw the light upon the table. Some shades cut out of paper that is green on the outside and white in the inside, and fitted upon

a conical frame-work in wire, are exceedingly useful, and perhaps more so than those of metal. The shades answer two purposes, the one to keep away superfluous heat and light from the eyes, and the other to throw a good light on the table. The heat is not entirely prevented by the metal shade, and is very annoying when the head is kept for some time in the neighbourhood of it; but by the paper one this is obviated, which renders it certainly the best for all purposes. The method of making these shades is described by Mr. Gwilt.* He takes half a sheet of good foolscap paper and strikes thereon two simicircles, as in fig. 96, the longest



Fig. 96.

diameter being thirteen inches, and the shorter one four inches, fitting and adapting it to a skeleton-sliding frame as the case may require, and then glueing or pasting the superfluous edges together.

When once properly fitted, another pattern may (previously to the glueing of the edges) be traced out and kept at hand, from which any number may at any time be drawn, and a new shade made when wanted, in less than ten minutes.

The head and eyes are more effectually protected from the heat by a contrivance of Mr. Nasmyth, by using two shades instead of one. The outer one is made about a quarter of an inch in diameter larger than the inner one, and both have tubes proceeding from them, which are raised so high as to cover the upper part of the chimney of the lamp. By this contrivance a current of cold air is continually passing between the two shades, and the outer one is consequently kept cool.

When it is wished to illuminate the room, and at the same time not to have the light in the eyes, one half of the shade may be dispensed with, the remaining part being supported by a ring of wire at the top and bottom, as in the frame which supports the paper shade.

By far the best lamps for burning are those on the bird-fountain principle, in which the oil is always presented to the wick at a certain level, and whether the reservoir be

* *Microscopic Journal*, vol. i. p. 58.

quite full or nearly empty, the light is perfectly uniform, which is not the case with the Cambridge lamp before described; the author for many years has used a small French lamp, Fig. 97, constructed on this principle, it has an exceedingly small wick, always burns well, and gives an excellent light; and the consumption of oil being small, in consequence of the minute size of the burner, it is highly advantageous in an economical point of view. There are many other little contrivances in this French lamp, which here deserve a separate description. The stem does not pass through the reservoir, as in the Cambridge lamp, but through a square piece of brass having two holes, one on either side of that through which the stem passes; these holes communicate with the reservoir, and the oil flows through them into the tube supporting the burner. By this arrangement the reservoir is placed on one side of the stem and the burner on the other, and the two balance each other. The gallery supporting the chimney is provided with ten fin-like pieces of soft brass, about three-quarters of an inch in length; these stand up in a circle and press against the sides of the chimney and keep it steady, they can be bent either inwards or outwards to fit any chimney that will go into the lower part of the gallery. The cup at the bottom of the burner, to hold the superfluous oil, is ingeniously furnished with a funnel-shaped mouth just above the screw, by which it is attached to the burner; the funnel receives all the oil that runs down the outside of the burner, and in it are two holes by which the oil may escape into the cup. This contrivance prevents the oil from flowing over the outside of the cup, which by these means is kept clean.

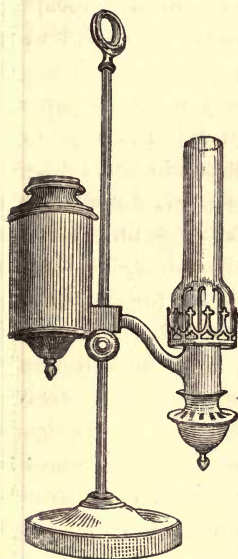

Fig. 97.

Some French lamps have a rack and pinion for raising the

wick, instead of a coarse screw. The pinion is attached near to the lower end of the burner, and is turned by a milled head, but from the circumstance of the pinion working in the oil, it is found that after a little use the oil will escape between the pinion and the collar in which it works, and will be continually dripping. These lamps are provided also with very long chimneys, and the gallery which supports the chimney is made to slide up and down the burner, so as to diminish or increase the intensity of the light; but by having a lamp of the form represented in the fig. 97, the long chimney and the risk of leakage are done away with. The only inconvenience in the use of the fountain lamp is that the reservoir may, by mistake or accident, be pulled up when nearly full of oil, and it sometimes happens, on returning it to its place, that some considerable quantity of oil will escape; this will, therefore, raise the level of it, and the wick receiving more than it can consume, the excess will escape by the interior and exterior tube of the burner, and the cup at the bottom to receive this excess will speedily fill and overflow. The first indication of this occurrence will be given by the elongation of the flame, and by its smoking, in consequence of the holes in the cup, which admit the air into the interior of the flame, being stopped up.

To ensure a good light from a lamp, many things must of necessity be attended to. The lamp should be perfectly clean, and the wick so long as to be at least one inch above the brass to which it is attached. The tube through which the air passes to supply the interior of the flame should be free from portions of charred wick, which often lodge in it, and the holes in the cup at the bottom of the burner must not be covered with oil. The oil itself ought to be the best sperm, and no lamp of the Cambridge kind should be put aside for a long time, but should be occasionally burnt. Those on the fountain principle will burn well even after having been out of use for some months, as the oil is kept continually on a level with the top of the wick, but in the other form, when the reservoir is not full, the oil has to find its way to the top of the wick by capillary attraction.

Particular attention ought to be paid to size and shape of the chimney. In passing a chimney over the flame into its place, it may be seen that there is one point where the flame is at the brightest, this point should be noticed, and if the glass when in its place does not keep the light at the same intensity, then the contracted part or shoulder of the chimney is either too high or too low for the surface of the wick; a few experiments will soon settle this point. If the maximum of light be obtained before the chimney comes into its proper place, then the contracted part or shoulder of the glass is not high enough; if, on the contrary, the maximum of light be not obtained, then the shoulder of the chimney is too high, hence the necessity of having a gallery that can be adjusted to chimneys of different heights, as recommended by Mr. Gwilt.* Generally speaking, the shoulder of the chimney should be on a level with the top of the wick, and its diameter at that part should not be more than two-thirds of an inch greater than that of the outside of the wick. Those chimneys, provided either with a disc of metal or talc, or which are contracted just above the wick, as seen in fig. 95, appear to answer the best, as with them the most intense light is produced. Chimneys have lately been made of a light blue or neutral tint glass, which answer their purpose uncommonly well, as they destroy completely the yellow colour of the flame, and render it beautifully bright. If a lamp having one of these chimneys be placed by the side of another having a chimney of the ordinary kind, the difference between the two will be very striking.

Chimney Shade.—This piece of apparatus is described by Mr. Holland, in the 49th vol. of the *Transactions of the Society of Arts*. It consists of a tube of brass, a little longer and broader than the chimney of the lamp, having on one side a brass plate with an aperture three-quarters of an inch in diameter, that can be moved up or down in front of the flame of the lamp by a rack and pinion. The tube cuts off all the light from the room, except that which can pass through the aperture above described, and its use is that of preventing any

* *Microscopical Journal*, vol. i., p. 56.

light from falling upon an opaque object, except that from the hole in the shade, in order that the light on it may be contrasted strongly with the surrounding dark medium. The author has used a shade of tinned iron, made black on the outside with size and lampblack, that answers the same purpose as the shade of Mr. Holland; but the plan of raising or depressing the hole for the light to pass through he did not adopt.

Oil.—The best oil for burning in lamps is that known as sperm. That obtained from the cocoa-nut is very cheap, and gives a good light, but it has rather a disagreeable smell, which is objectionable; besides it is very acid in its nature, and lamps in which it is used should be either entirely made of tinned iron, or, if of brass, they should be tinned in the inside. Any lamp which burns this oil will be noticed to have all brass work in contact with the oil speedily coated with verdigris. The common solar oil will burn very well in the fountain lamps, especially if the chimney be constructed like that in fig. 95, but in all those with the flat reservoir it is far too cloggy. Some persons are in the habit of burning a common kind of Florence or olive oil, but it does not answer so well as sperm, as, like the solar, it succeeds better in the fountain lamps than in those with a flat reservoir.

Jatropha Oil.—The author has lately been informed by his friend, J. B. Estlin, Esq., of Bristol, that an oil, extracted from the berries of a shrub of the genus *Jatropha*, found in the Cape de Verd Islands, is used by all the microscopists in that city; it burns well, gives a very bright light, and is perfectly free from smell; it does not clog, but will keep pure in lamps for a very long time, the only thing requiring attention is that the lamp be warmed after it is trimmed before being lighted. Messrs. Visger and Miller, of Bristol, are the sole importers of these berries and manufacturers of the oil, and the price, which also is a recommendation, varies from 4s. 6d. to 5s. per gallon.

Cleaning Lamps.—Lamps may be cleaned by nearly filling the reservoir with a solution of caustic potash, and allowing it to stand for a day or two, when all the old oil will be converted into soap. The potash can then be thrown out and

the lamp repeatedly rinsed with warm water until it is sufficiently clean, which is known by the water coming out quite pure; some boiling water may now be poured in and be allowed to remain for a few minutes to thoroughly warm every part; it must then be poured out, and the lamp turned upside down and kept near a fire until it is dry; when it is fit for use again. Care must, however, be taken not to allow the potash to run over on the outside of any part of the lamp, as it will destroy whatever bronze or paint it comes in contact with.

When the lamp is required to be used immediately after cleaning, turpentine or camphine may be employed with great advantage, it readily dissolves the old oil, and even if a small quantity has been left in, it will mix readily with new oil, and all the trouble of the potash and hot water will be avoided.

Portable Candle Lamp.—Mr. Jackson, to whom we are indebted for so many improvements in the mechanical arrangements of the microscope, employs as a substitute for a lamp a candle lamp of the following construction:—*a*, fig. 98, represents a brass foot about three inches in diameter, into which is screwed a tube *b*, about six inches long and one in diameter. Within this slides a smaller tube, that is provided with a cylinder of wax, which is pressed on by a spiral spring, like a Palmer's candle; the upper part of this inner tube is seen at *d*, it has fastened to it a disc of brass, having a rim on its outer edge to support the chimney *c*, which is kept firmly in its place by a thin circular ring of brass having three notches in its outer margin; these fit under three wedged-shaped pieces of metal on the edge of the disc, and prevent the chimney from falling off. The cylinder of wax is not provided with a wick, but a short piece of twisted cotton, to answer

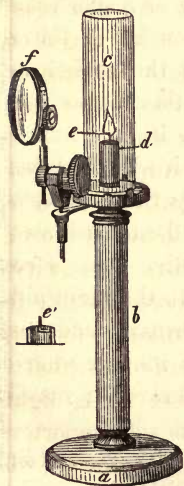

Fig. 98.

the purpose of a wick, is placed upon a sharp point of wire, as seen at *e'*. A condensing lens *f*, provided with all the usual movements for adjustment, can be attached to a small fin-

like process connected with the disc of metal carrying the chimney, and by it both opaque and transparent objects can be illuminated.

For convenience of carriage, the tube, and the chimney *c*, can be removed, and the inner tube *d* having been pulled out of *b*, the chimney, with a cylinder of wood covered with cloth, can be slid over the tube *b*, and the whole will then pack in a small compass. The cylinders of wax are similar to those constructed by Molyneux, but the first mention of their application as an illuminator for the microscope was made by Mr. Jackson to the Microscopical Society in 1841.

A wax candle will be found to give a very pure white light, and may be used as a substitute for the lamp; but unless the flame is covered with a chimney, the constant flickering from currents of air, occasioned by persons moving about in the room, becomes an annoyance. The level of the flame is also constantly varying as the candle is being consumed, hence it is necessary to employ such a candlestick as that represented by fig. 99; by means of which either a long or a short piece

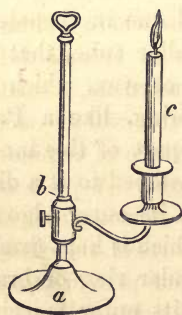

Fig. 99.

of candle *c* may be brought to the required height by raising the socket into which the candle fits either up or down the stem *b* that supports it, and fixing it by a screw. A foot *a*, loaded with lead, will be required to keep the candlestick perfectly steady. Mr. Pritchard sometimes employs a candlestick that is connected by a jointed arm to the main pillar of the microscope, this forms a steady support for it, and allows of its being moved with the microscope wherever it may be required.

Those who may have their houses supplied with gas will find that by means of a flexible tube connected with an argand or other burner, mounted on a moveable stand, they will get a very convenient light for all purposes. If, for instance, in the centre of the room there be a chandelier, then a flexible tube may be screwed to one of the pipes, and being attached

by its opposite end to a burner, the tube will allow of its being moved about to all parts of the table where it may be required. If the table be a fixture, a large gas pipe, having a number of screws at the top to receive union joints, may be brought up through its centre, and as many burners as may be required attached to the central pipe by means of flexible tubes. In all cases the argand burner should be mounted on a stand similar to that on which the oil lamps, figs. 95 and 97 are mounted, so that the flame may be raised or depressed to suit every kind of microscope.

Many persons are now in the habit of burning camphine lamps; these are most frequently too high for the microscope, and the reservoir being large and immediately under the light, prevents their use, unless the microscope is placed at some considerable distance from the lamp. Mr. Gillett, whose improved method of illumination of transparent objects I shall have presently to describe, employs a small camphine lamp, mounted on an adjustable stand, for the purpose. The method of applying his important principles to the illumination of test objects will need a separate description.

To Clean Chimneys of Lamps.—In all cases where a chimney is used with a lamp, it is liable at times to become dull and smoky; this cannot be washed off by water alone, a small quantity of hydrochloric acid added to the water will at once remove it. When this is not at hand, a mixture of common salt and vinegar will answer the same purpose. A piece of flannel fastened to the end of a stick and dipped into either of these liquids will serve to convey it to all parts of the glass. Care must be taken to have the chimney wiped perfectly dry before it is put over the flame, otherwise it is liable to crack; and when the lamp is first lighted, it is advisable to have the entire circle of the wick lighted before the chimney is put on: some persons put the chimney on when only a portion of the wick is lighted, this is always attended with risk.

CHAPTER V.

ON THE MAGNIFYING POWERS USED WITH SIMPLE AND
ACHROMATIC COMPOUND MICROSCOPES.

IT has been previously stated, at page 64, that the magnifying powers employed with the simple microscopes may be divided into those consisting of one lens only, or into those of two or three lenses combined, and termed, in consequence, either doublets or triplets. The former was stated to answer uncommonly well for all the lowest powers, and the latter for the highest. It would be foreign to our purpose to enter in detail into all the different methods of constructing the magnifying powers or lenses that from time to time have occupied the attention of the learned in this and other countries, nor will it be necessary to trace the alteration in course that the rays of light undergo in their passage through lenses of the various figures employed in optical instruments, as these will be found fully described in the works exclusively devoted to this subject; but in order to understand in what an achromatic object-glass differs from one of the ordinary construction, it will be requisite, in the first place, that certain terms, such as spherical and chromatic aberration, and angle of aperture, be fully understood. Most persons are familiar with the fact that when parallel rays of light fall upon a plano or double convex lens, they are brought to a point at a certain distance from the lens, which point is termed their focus. Thus suppose in fig. 100 that the rays LL , &c., which are drawn parallel, are, after passing through the planoconvex lens, brought to a focus at F , this would take place if the lens were perfect; but it is found in practice, that instead of meeting in a single point F , the rays are subject to two different causes of error or aberration: the first is called the spherical, the second the chromatic aberration; and as no lens can be made except that seen in section in figs. 100 and 101, viz., the planoconvex, without both its surfaces being portions of spheres; and it has been abundantly proved, by experiment, that no

lens with a spherical surface can bring the rays of light issuing from one point into the focus at another point, all must

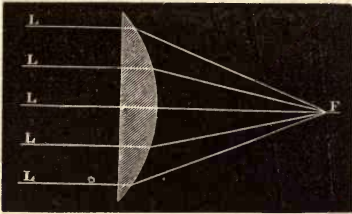

Fig. 100.

be subject to what is termed *spherical aberration*, as shown in fig. 101, where L L, &c., represent five parallel rays of light, the two outer of these will be brought into a focus at F, whilst the three central ones will be refracted to a more distant point at *f*, the distance from F to *f* being called the *longitudinal spherical aberration*. If the lens were placed with its convex side towards the parallel

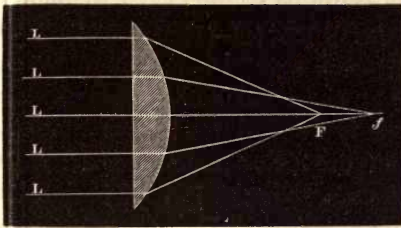

Fig. 101.

rays, the aberration would then be but trifling: the same result would be obtained even if the lens were equally convex on both sides. A second difficulty now arises, termed *chromatic aberration*; whatever be the form of the surface of the lens opposed to the light, the material itself will act upon different portions of each ray with different forces, and separate the white light into a variety of colours; this effect is represented by fig. 102, L L, &c., are parallel rays

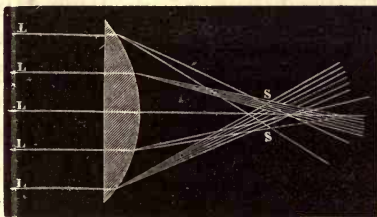

Fig. 102.

of light falling upon a plano-convex lens; two of these, one from the margin, the other from nearer the centre, are shown as dispersed and coloured, as in the spectrum formed by a prism; these coloured rays will

cross each other at S S, the violet, being more refrangible than the red, will be brought to a focus the nearest to the lens; so that, besides the spherical, there is the chromatic aberration.

The lenticular form of the glass does not of itself decompose the light, but whenever a ray passes from one medium into another more or less refractive, the dispersion is certain to take place. As every lens, according to its figure, is more or less subject to these two kinds of aberrations, it becomes necessary to ascertain how such sources of error may be remedied: this, as will presently be shown, can be accomplished by the employment of two or more lenses, whereby the light that has traversed the centre of the first lens may be made in the second to pass through near the margin; the defect may also, in some measure, be counteracted by diminishing the aperture of the lens, by placing a stop or diaphragm behind it, to cut off the peripheral rays; but this, in all cases, is attended with loss of light; and although the lens defines better, its penetrating power is reduced in a like proportion. For all lenses of very low power that are employed with simple microscopes for dissecting, the spherical and chromatic aberration need hardly be considered; it is only when the higher powers are required either to be used singly or as object-glasses for the compound instrument, that the two kinds of aberration must of necessity be done away with, or, in other words, that the aperture be increased without interfering with definition. The spherical aberration may be considerably diminished by attending to the figure of the lens employed; thus, if it be a planoconvex, the convex side should be placed towards the eye; if a double convex, it has been found in practice that one whose radii are in the proportion of one to six is the form in which the aberration is the least; but it can be entirely got rid of by combinations of lenses so disposed, that their opposite aberrations may correct each other; this was first accomplished in a satisfactory manner by the doublet of Dr. Wollaston, before described in pages 30 and 65, as consisting of two planoconvex lenses whose focal lengths are in the proportion of one to three, the lens of shortest focus being placed next the object, and the convex surfaces of both directed towards the eye, with a stop or diaphragm between them. Wollaston did not employ the stop, as his doublets were of such high power, that the lenses nearly touched each other.

The action of the doublet will be best understood by the diagram, fig. 103, copied from Mr. Ross's article "Microscope,"

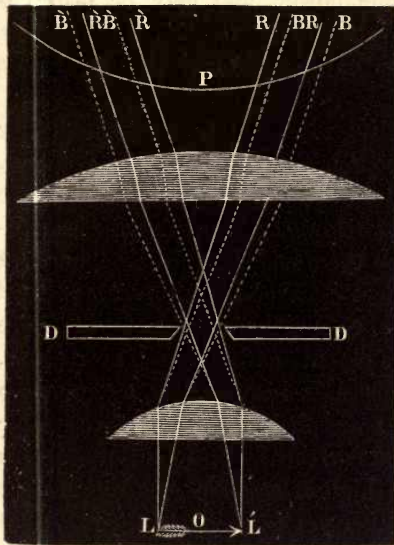

Fig. 103.

before alluded to, where P represents a portion of the pupil, D D the diaphragm or stop, and L O L' the object. Each of the pencils of light from the extremities of the object L L' is rendered eccentric by the stop, and the ray that passed through the first lens near to the centre is made to pass through the periphery of the second lens, and even on the opposite side of the common axis P O; thus each is affected by opposite errors which, in some measure, neutralise each

other, and the rays, R B, R B emanating from L, being bent to the right in the lower lens, and to the left in the upper, and, as the most refrangible of the coloured rays the blue, is altered in its course at each bending, and falls near the margin of the second lens, where the refraction is more powerful than in the centre, the blue and red rays, will emerge very nearly parallel, and, consequently, colourless to the eye; thus the chromatic aberration is almost, if not entirely destroyed, whilst the spherical has been considerably diminished by the circumstance that the side of the pencil which passes one lens nearest the axis, passes the other nearest the margin. But however carefully a doublet of this form may be constructed, there must of necessity be some small amount of error; the central pencil will occupy the same relative position in both lenses, the correction of this, consequently, will be imperfect, and all those rays intermediate between the centre and the margin will

vary according to their distance from one or the other; but allowing this, the doublet is nevertheless vastly superior to any single lens of the same power, and may be made to transmit a pencil of an angle from 35° to 50° , without any very sensible errors, and to exhibit most of the usual test objects.

Another most important improvement in the magnifying power of the simple microscope is the triplet of Mr. Holland, before described in pages 31 and 65; in this instrument three lenses are employed, the two lowest being placed close together, and the stop between them and the third. The first bending of the rays being accomplished by two lenses instead of one, the aberrations are so much diminished, that the second bending neutralizes them entirely. The triplet, though composed of three lenses, is, nevertheless, a doublet in its action, and is capable of transmitting a pencil of sixty-five degrees with distinctness and correctness of definition. With the triplet we arrive at the highest stage of perfection that the single microscope has ever yet attained, as the errors of spherical and chromatic aberration, to which all single lenses are more or less subject, are entirely destroyed; but however well either the triplet or the doublet may perform separately, they will not answer well as object-glasses to the compound microscope, where any error, however slight, in the object-glass, is further magnified by the eye-piece; the construction of a magnifying power for the compound microscope is, therefore, a more complicated matter than that either of a doublet or triplet, for not only must several lenses be employed to form one magnifier, but even two different kinds of glass must be used for one lens of such magnifier; and throughout the whole range of optical science, perhaps there is no single problem that has ever yet engaged so much of the attention of the learned, in all countries, as that of achromatism; and of all the triumphs in science that have been achieved by a combination of the labours of the mathematician and the workman, no one can outvie in delicacy of construction and in importance a well made achromatic combination.

In order to understand the different parts entering into the

composition of a perfect object-glass for the compound microscope, it must be first shown how the rays of light comport themselves in their passage through a compound microscope, one of the ordinary kind that is not achromatic. Fig. 104

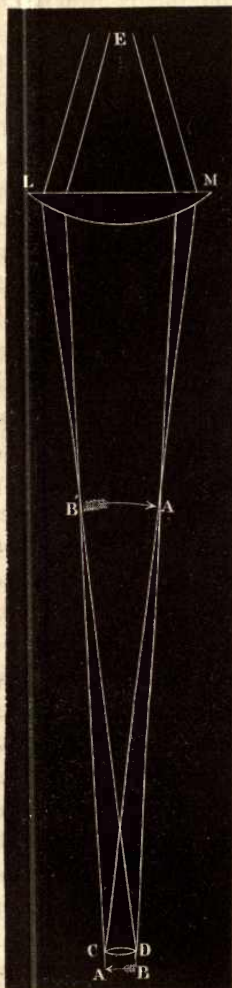

Fig. 104.

represents a compound microscope of two lenses, AB being an object, CD the object-glass, and LM the eye-glass. The rays proceeding from the object AB are acted on by the lens CD, and are brought to a focus at B'A'; but not being intercepted there, they cross and pass on till they reach the eye-glass LM, by which they are rendered nearly parallel, and as such reach the eye, the image B'A' answering as an object to the single lens LM. The magnifying power of the compound microscope depends on two circumstances; first, the focus of the lens, that is the distance of CA or DB, and, secondly, the posterior focus CB' or DA', the power may be increased by substituting a lens of shorter focal length than CD, or by making the distance between CD and LM greater, and by the addition of a second lens at the eye end, the field of view is by this much increased, and we have formed what is termed an eye-piece; but by this arrangement nothing has been done to diminish either the spherical or the chromatic aberration. One very great advantage which the compound has over the simple microscope, besides the greater magnifying power, is that the field of view is large and equally good

in all directions, whereas, in the simple, the field is small and only good in the centre. However well an instru-

ment of this kind be constructed, it will fail to exhibit even many of the ordinary test objects; it is, therefore, unfit for the purposes of scientific investigation, for in the diagram given at fig. 104, it must not be supposed that the image of the object formed by B' A' is a correct one; on the contrary, all the space between that arrow and the one drawn immediately above it, is occupied by an infinite number of variously coloured images of different sizes, those nearest CD being blue, and those most distant red, the effect of which is to destroy definition and to render the image obscure. To overcome all these difficulties has been a labour of years, and for an account of the various steps towards improvement which have taken place, the reader must consult the latter part of the *History of the Microscope*, beginning at page 32, where these points are described in chronological order.

The first attempts to achromatise the object-glass were not very successful; and we find that within the last twenty years such philosophers as Biot and Wollaston predicted that the compound microscope would never excel the simple when supplied with doublets. Happily for us such opinions have been since found to be groundless, "and the compound microscope," says Mr. Ross,* "within the last fifteen years, has been elevated from the condition previously described, to that of being the most important instrument ever yet bestowed by art upon the investigator of nature."

In the year 1824, without knowing what had been done on the Continent by Amici, Fraunhofer, Selligues, and Chevalier, the late Mr. Tulley, of London, succeeded in making the first English achromatic object-glass for a compound microscope; it was composed of three lenses, and was capable of transmitting a pencil of 18° ; he soon after constructed another combination to be placed in front of the first mentioned, which increased the angle of the pencil to 38° , thus was the difficulty overcome. Mr. Tulley's object-glass exhibited a flat field, and was perfectly corrected; to it also was applied an eye-piece, by which the magnifying power produced was one hundred and twenty diameters; but

* *Penny Cyclopædia*, Art., Microscope.

when the second combination was added, the power was increased to three hundred. Mr. Tulley was encouraged and greatly aided in his researches by Dr. Goring and Mr. Joseph Jackson Lister, but still he never obtained, by his own combinations, an angular aperture beyond thirty-eight or forty degrees: it was left for Mr. Lister, in 1829, to point out how lenses could be combined so as to give a perfectly flat field, and at the same time to transmit a pencil of 50° . Mr. Lister's paper, as before stated, at page 40, was published in the *Philosophical Transactions of the Royal Society*, and so valuable was the information afforded by it, that from the time of its publication up to the present, it has been the foundation of all the improvements in the achromatic microscopes made in England. In the doublet of Wollaston, and in the triplet of Mr. Holland, before described, the lenses were all made of the same kind of material; but in order to render an object-glass for a compound microscope achromatic, glass of two different densities must be employed, as in the telescope invented by Dollond, and still in use. To form a planoconvex lens of these materials flint glass was used as the planoconcave and crown for the double convex; one of the surfaces of the latter being accurately ground to fit into the concavity of the former, as shown by fig. 105, so that when the two were thus combined, a planoconvex lens was formed. Previous to Mr. Lister's discoveries, the two lenses were, in most cases, accurately fitted to each other, but he suggested that the flint glass should be planoconcave, and that it should be joined to the convex by some highly refracting cement, such as Canada balsam. The first condition, he states, obviates the risk of error in centring the two curves, and the second diminishes by nearly one-half the loss of light from reflection, which is very great at the numerous surfaces of a combination, and besides the making of the field more clear, all dewiness and vegetation are prevented from growing between the glasses. These two conditions, then, that the flint lens shall be planoconcave, and that it shall be joined by some cement to the convex, are taken as the basis for the microscopic object-glass, provided they can be reconciled with the destruc-

tion of the spherical and chromatic aberration of a large pencil. For all the detail connected with this important subject, the reader is referred to the paper itself in the *Philosophical Transactions*, where will be found the various steps by which Mr. Lister was led to such valuable results. The achromatic object-glasses made by our three most eminent opticians, Messrs. Powell, Ross, and Smith, consist of two or three compound lenses, which cannot be used separately, but are fixed into a long tube or case, as shown by fig. 22, page 42, or else in section in fig. 105, where A represents the anterior pair of lenses, M

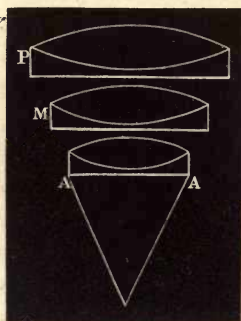

Fig. 105.

represents the anterior pair of lenses, M the middle, and P the posterior, the three sets combined form the achromatic object-glass; and all the first rate instruments are supplied with as many as five or six of these objectives of different powers from 20 up to 2000 diameters; but the great expense, of their manufacture has been always a bar to the more general employment of the achromatic microscope; and in order to

remedy the evil, other combinations have been constructed in which the last lens, or that nearest the object, may be removed; by this proceeding the magnifying power is very much diminished, but the remainder of the combination is so adjusted, that with the addition of a dark stop drawn over the last lens, it will answer very well for the lower powers. Messrs. Smith and Beck supply with their microscopes two sets of object-glasses, the front lenses of which slip on or off, so that four different powers may be formed, varying in their focal length from one-inch-and-a-half to one-eighth of an inch; Messrs. Powell and Ross, on the contrary, always supply distinct combinations. The object-glasses made on the Continent consist of sets of three or more, screwed one upon the other; of these, the first, second, or third may be used separately or combined, by this means three different powers may be obtained, but as no single objective of two lenses can be perfectly corrected, these object-glasses can only act well when all three sets are combined. A section of a modern

compound achromatic microscope, as manufactured by our best makers, is represented by fig. 106, where O is an object,

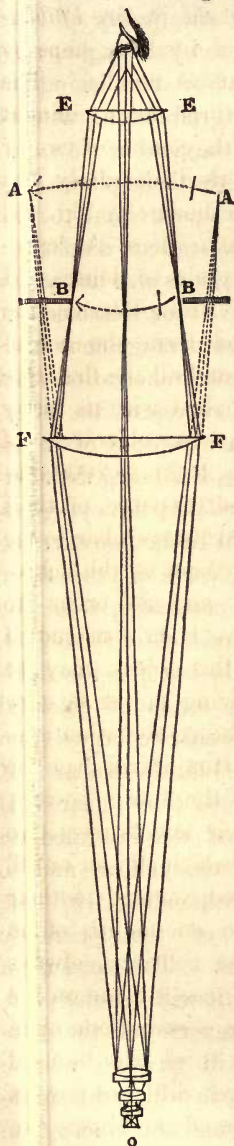

Fig. 106.

and above it is seen the triple achromatic object-glass, in connection with the eye-piece $E E, F F$, the planoconvex lens $E E$ being the eye-glass, and $F F$ the field-glass, and between them at $B B$ a dark stop or diaphragm. The course of the light is shown by three rays, drawn from the centre, and three from each end of the object O ; these rays, if not prevented by the lens $F F$, or the diaphragm at $B B$, would form an image at $A A$; but as they meet with the lens $F F$ in their passage, they are converged by it and meet at $B B$, where the diaphragm is placed to intercept all the light except that required for the formation of a perfect image, the image at $B B$ is further magnified by the lens $E E$, as if it were an original object in the manner described at pages 67 and 138. The triple achromatic combination constructed on Mr. Lister's improved plan, although capable of transmitting large angular pencils, and corrected as to its own errors of spherical and chromatic aberration, would, nevertheless, be of little service without an eye-piece of peculiar construction. As this subject has been so admirably treated by Mr. Ross, in the *Penny Cyclopædia*, it has been thought most desirable to quote his own words, as follows:—

“If we stopped here,” says Mr. Ross, “we should convey a very imperfect idea of the beautiful series of corrections effected by the eye-

piece, and which were first pointed out in detail in a paper on the subject, published by Mr. Varley, in the fifty-first volume of the *Transactions of the Society of Arts*. The eye-piece in question was invented by Huyghens for telescopes, with no other view than that of diminishing the spherical aberration by producing the refractions at two glasses instead of one, and of increasing the field of view. It consists of two planoconvex lenses, with their plane sides towards the eye, and placed at a distance apart equal to half the sum of their focal lengths, with a stop or diaphragm placed midway between the lenses. Huyghens was not aware of the value of his eye-piece, it was reserved for Boscovich to point out that he had by this important arrangement accidentally corrected a great part of the chromatic aberration. Let

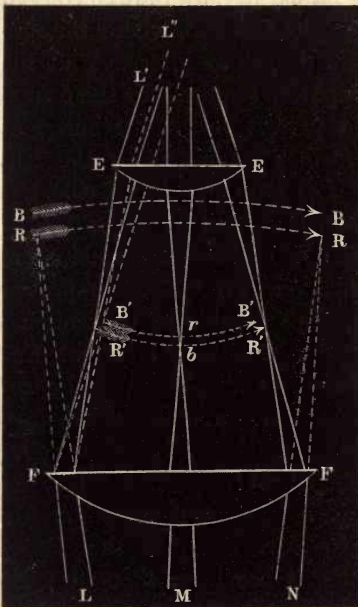

Fig. 107.

fig. 107 represent the Huyghenian eye-piece of a microscope, F F being the field-glass and E E the eye-glass, and L M N the two extreme rays of each of the three pencils, emanating from the centre and ends of the object, of which, but for the field-glass, a series of coloured images would be formed from R R to B B; those near R R being red, those near B B blue, and the intermediate ones green, yellow, and so on, corresponding with the colours of the prismatic spectrum. This order of colours, it will be observed, is the reverse of that described in treating of the

common compound microscope (fig. 104), in which the single object-glass projected the red image beyond the blue. The effect just described, of projecting the blue image beyond the red, is purposely produced for reasons presently to be given,

and is called over-correcting the object-glass as to colour. It is to be observed also, that the images BB and RR are curved in the wrong direction, to be distinctly seen by a convex eye-lens, and this is a further defect of the compound microscope of two lenses. But the field-glass, at the same time that it bends the rays and converges them to foci at $B'B'$ and $R'R'$, also reverses the curvature of the images as there shown, and gives them the form best adapted for distinct vision by the eye-glass EE . The field-glass has at the same time brought the blue and red images closer together, so that they are adapted to pass uncoloured through the eye-glass. To render this important point more intelligible, let it be supposed that the object-glass had not been over-corrected, that it had been perfectly achromatic; the rays would then have become coloured as soon as they had passed the field-glass; the blue rays, to take the central pencil for example, would converge at b , and the red rays at r , which is just the reverse of what the eye-lens requires; for as its blue focus is also shorter than its red, it would demand rather that the blue image should be at r , and the red at b . This effect we have shown to be produced by the over-correction of the object-glass, which protrudes the blue foci BB as much beyond the red foci RR as the sum of the distances between the red and blue foci of the field-lens and eye-lens; so that the separation BR is exactly taken up in passing through those two lenses, and the whole of the colours coincide as to focal distance as soon as the rays have passed the eye-lens. But while they coincide as to distance, they differ in another respect; the blue images are rendered smaller than the red by the superior refractive power of the field-glass upon the blue rays. In tracing the pencil L for instance, it will be noticed that after passing the field-glass, two sets of lines are drawn, one whole, and one dotted, the former representing the red, and the latter the blue rays. This is the accidental effect in the Huyghenian eye-piece pointed out by Boscovich. The separation into colours of the field-glass is like the over-correction of the object-glass; it leads to a subsequent complete correction. For if the differently coloured rays were kept together till they reached

the eye-glass, they would then become coloured, and present coloured images to the eye; but, fortunately, and most beautifully, the separation effected by the field-glass causes the blue rays to fall so much nearer the centre of the eye-glass, where, owing to the spherical figure, the refractive power is less than at the margin, that the spherical error of the eye-lens constitutes a nearly perfect balance to the chromatic dispersion of the field-lens, and the red and blue rays L' and L'' emerge sensibly parallel, presenting, in consequence, the perfect definition of a single point to the eye. The same reasoning is true of the intermediate colours and of the other pencils."

From what has been stated, it is obvious that we mean, by an achromatic object-glass, one in which the usual order of dispersion is so far reversed, that the light, after undergoing the singularly beautiful series of changes effected by the eye-piece, shall come uncoloured to the eye. We can give no specific rules for producing these results. Close study of the formulæ for achromatism, given by the celebrated mathematicians we have quoted, will do much, but the principles must be brought to the test of repeated experiment. Nor will the experiments be worth anything, unless the curves be most accurately measured and worked, and the lenses centred and adjusted with a degree of precision which, to those who are familiar only with telescopes, will be quite unprecedented. When object-glasses of high power, constructed upon the improved plan of Mr. Lister, came to be accurately tested, Mr. Ross found out that if they exhibited well objects that were uncovered, they did not show so beautifully those that were covered with thin glass or mica, with or without being immersed in fluid. He speedily found a remedy, which, in order to be fully understood, must be described in his own words, taken either from the original paper in the *Transactions of the Society of Arts*, or from the article "Microscope," in the *Penny Cyclopædia*, which has been already so often quoted.

"Mr. Lister's new principles were applied and exhibited by Mr. Hugh Powell and Mr. Andrew Ross, with a degree of success that had never been anticipated; so perfect, indeed,

were the corrections given to the achromatic object-glass—so completely were the errors of sphericity and dispersion balanced or destroyed—that the circumstance of covering the object with a plate of the thinnest glass or mica disturbed the corrections, if they had been adapted to an uncovered object, and rendered an object-glass, which was perfect under one condition, sensibly defective under the other. This defect, if that should be called a defect which arose out of improvement, was first discovered by Mr. Ross, who immediately suggested the means of correcting it, and presented to the Society of Arts, in 1837, a paper on the subject, which was published in the fifty-first volume of their *Transactions*, and which, as it is, like Mr. Lister's, essential to a full understanding of the ultimate refinements of the instrument, we shall extract nearly in full:—

“ In the course of a practical investigation,” says Mr. Ross, “ with a view of constructing a combination of lenses for the object-glass of a compound microscope, which should be free from the effects of aberration, both for central and oblique pencils of great angle, I combined the condition of the greatest possible distance between the object and object-glass; for in object-glasses of short focal length, their closeness to the object has been an obstacle in many cases to the use of high magnifying powers, and is a constant source of inconvenience.

“ In the improved combination, the diameter is only sufficient to admit the proper pencil; the convex lenses are wrought to an edge, and the concave have only sufficient thickness to support their figure; consequently, the combination is the thinnest possible; and it follows that there will be the greatest distance between the object and the object-glass. The focal length is one-eighth of an inch, having an angular aperture of 60° , with a distance of one-twenty-fifth of an inch and a magnifying power of 970 times linear, with perfect definition on the most difficult Podura scales. I have made object-glasses of one-sixteenth of an inch focal length; but as the angular aperture cannot be advantageously increased, if the greatest distance between the object and the object-glass

is preserved, their use will be very limited. The quality of the definition produced by an achromatic compound microscope will depend upon the accuracy with which the aberrations, both chromatic and spherical, are balanced, together with the general perfection of the workmanship. Now, in Wollaston's doublets and Holland's triplets, there are no means of producing a balance of the aberrations, as they are composed of convex lenses only; therefore the best that can be done, is to make the aberrations a minimum; the remaining positive aberration in these forms produces its peculiar effect upon objects (particularly the detail of the thin transparent class) which may lead to misapprehension of their true structure; but with the achromatic object-glass, where the aberrations are correctly balanced, the most minute parts of an object are accurately displayed, so that a satisfactory judgment of their character may be formed. It will be seen by fig. 108, that when a certain angular pencil $A O A'$ proceeds from the object O , and is incident on the plane side of the first lens, if the combination is removed from the object, as in fig. 109, the extreme rays of the pencil impinge on the more

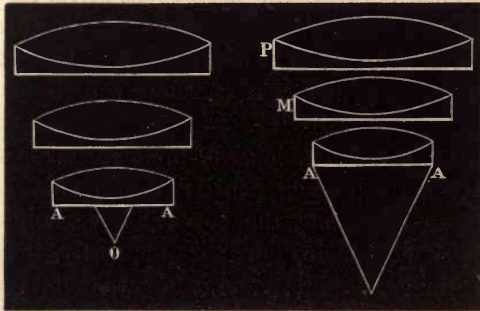

Fig. 108.

Fig. 109.

marginal parts of the glass, and as the refractions are greater here, the aberrations will be greater also. Now, if two compound object-glasses have their aberrations balanced, one being situated as in fig. 108, and the other as in fig. 109, and the same disturbing power applied to both, that in which the angles of incidence and the aberrations are small will not

be so much disturbed as where the angles are great, and where, consequently, the aberrations increase rapidly.

“ When an object-glass has its aberrations balanced for viewing an opaque object, and it is required to examine that object by transmitted light, the correction will remain; but if it is necessary to immerse the object in a fluid, or to cover it with glass or mica, an aberration will arise from these circumstances which will disturb the previous correction, and, consequently, deteriorate the definition: and this effect will be more obvious with the increase of the distance between the object and the object-glass. The aberration produced with diverging rays by a piece of flat and parallel glass, such as would be used for covering an object, is represented at fig. 110,

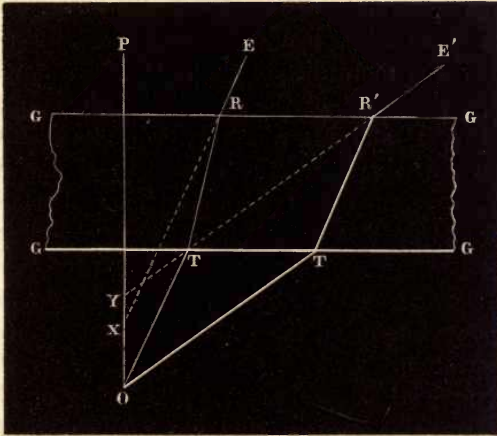

Fig. 110.

where $GGGG$ is the refracting medium, or a piece of glass covering the object O and OP , the axis of the pencil, perpendicular to the flat surfaces; OT a ray near the axis; and OT' the extreme ray of the pencil incident on the under surface of the glass: then TR TR' will be the directions of the rays in the medium, and RE RE' those of the emergent rays. Now, if the course of these rays is continued as by the dotted lines, they will be found to intersect the axis at different distances X and Y from the surface of the glass; and the distance XY is the aberration produced by the medium

which, as before stated, interferes with the previously balanced aberrations of the several lenses composing the object-glass. There are many cases of this, but the one here selected serves best to illustrate the principle. If an object-glass is constructed as represented by fig. 109, where the posterior combination P and the middle M have together an excess of negative aberration; and if this be corrected by the anterior combination A, having an excess of positive aberration, then this latter combination can be made to act more or less powerfully upon P and M, by making it approach to or recede from them; for when the three are in close contact, the distance of the object from the object-glass is greatest; and, consequently, the rays from the object are diverging from a point at a greater distance than when the combinations are separated, and as a lens bends the rays more, or acts with greater effect, the more distant the object is from which the rays diverge, the effect of the anterior combination A upon the other two, P and M, will vary with its distance from thence. When, therefore, the correction of the whole is effected for an opaque object, with a certain distance between the anterior and middle combination, if they are then put in contact, the distance between the object and the object-glass will be increased; consequently the anterior combination will act more powerfully, and the whole will have an excess of positive aberration. Now, the effect of the aberration produced by a piece of flat and parallel glass being of the negative character, it is obvious that the above considerations suggest the means of correction by moving the lenses nearer together, till the positive aberration thereby produced balances the negative aberration caused by the medium. The preceding refers only to the spherical aberration, but the effect of the chromatic is also seen when an object is covered with a piece of glass; for in the course of my experiments, I observed that it produced a chromatic thickening of the outline of the Podura and other delicate scales; and if diverging rays near the axis and at the margin are projected through a piece of flat parallel glass, with the various indices of refraction for the different colours, it will be seen that each ray will emerge

separated into a beam consisting of the component colours of the ray, and that each beam is widely different in form. This difference being magnified by the power of the microscope, readily accounts for the chromatic thickening of the outline just mentioned. Therefore, to obtain the finest definition of extremely delicate and minute objects, they should be viewed without a covering; if it be desirable to immerse them in fluid, they should be covered with the thinnest possible film of mica or glass, as from the character of the chromatic aberration, it will be seen that varying the distances of the combinations will not sensibly affect the correction; though object-lenses may be made to include a given fluid or solid medium in their correction for colour.

The mechanism for applying these principles to the correction of an object-glass under the various circumstances, has been already described at page 42, where also was shown, by fig. 22, a vertical section of an achromatic object-glass, of one-eighth of an inch focus, the mode of making the adjustments will be fully described in the chapter devoted to test objects.

“It is hardly necessary to observe,” says Mr. Ross, “that the necessity for this correction is wholly independent of any particular construction of the object-glass; as in all cases where the object-glass is corrected for an object uncovered, any covering of glass will create a different value of aberration to the first lens which previously balanced the aberration resulting from the rest of the lenses; and as this disturbance is effected at the first refraction, it is independent of the other part of the combination. The visibility of the effect depends on the distance of the object from the object-glass, the angle of the pencil transmitted, the focal length of the combination, the thickness of the glass covering the object, and the general perfection of the corrections for chromatism and the oblique pencils.

The object-glasses that are supplied with the adjustment, for thickness of glass, are the highest powers, viz., the one-sixteenth of an inch in focal length, the one-eighth, the one-fourth, and, in some cases, the one-half; in all the powers

lower than these, the adjustment is not required, as the thickness of the glass cover does not materially interfere with their definition.

The eye-pieces supplied with the compound microscopes are of the Huyghenian principle before described, and are generally three in number; they may be designated by the letters A, B, and C, the first being the lowest in power, the last the highest. Those of Messrs. Powell and Smith are so constructed, that with the one-inch object-glass the magnifying power with A will be about 30, with B 60, and C 100, or in the proportion of 1, 2, 3; but Mr. Ross varies the power of the second or B, and his proportion is about $1.1\frac{1}{2}$ and $2\frac{1}{2}$. The lowest, or that marked A, is the one more commonly employed, the others, especially C, is not so frequently used, in consequence of the loss of light, and, in some cases, of definition as well; but all are extremely necessary when we wish to gain an increase in the magnifying power without the employment of a higher object-glass. Two other forms of eye-piece are sometimes employed; one of these was invented by Ramsden; it consists of two planoconvex lenses with the field-lens reversed; that is, in the Huyghenian form both the lenses are placed with their flat surfaces towards the eye, but in this, by Ramsden, the convex surface of the field-lens only occupies that position; this arrangement involves no correction for colour or spherical aberration, in all other respects it is superior to the Huyghenian. It is used always as a micrometer. If a divided glass scale or fine wires be placed exactly where the image formed by the object-glass is situated, the scale and the image will be magnified together, and every part of the image will be, as it were, brought in contact with a scale, the value of each of the divisions of which can be accurately ascertained, even to the one-twenty-thousandth of an inch. The image formed by this eye-piece is not reversed as in the Huyghenian form, hence it has received the name of a positive eye-piece, in contradistinction to that of Huyghens, which is termed a negative one; but however accurately such an eye-piece be made, its defining power is not so good as that

of Huyghens, but Mr. Ross states, that if the glasses were made up of two achromatic combinations, this eye-piece would be by far the most perfect of all, both for telescopes and microscopes. Some persons employ either two plano-convex or double convex lenses as a substitute for the single lens of the eye-glass, in order that the field of view may be greatly increased without any great regard to the correctness of the details. For this purpose, Dr. Carpenter states,*—“That he has been in the habit of using an eye-piece consisting of a meniscus, having the concave side next the eye, and a convex lens, having the form of least aberration with its flattest side next the object; this form nearly resembles Herschell’s aplanatic doublet. The field-glass also is a double convex lens of the form of least aberration. With this eye-piece he was enabled to obtain a field of fourteen inches in diameter (measured at the usual distance—ten inches), equally distinct and well illuminated over every part, and admirably adapted for the display of sections of wood, wings of insects, and objects of a similar description, and also for opaque objects. When employing it for these purposes, he prefers using a single lens as an object-glass instead of an achromatic one, as the latter are adjusted for a much smaller field of view, and produce an image which is distinct only in the centre.

The power of the microscope may be greatly increased, not only by using different eye-pieces and object-glasses, but also by increasing the distance between them by the draw-tube, described in page 69. For instance, suppose that the one inch object-glass and the lowest eye-piece are employed, and that without the draw-tube the magnifying power was thirty-five, and with the second eye-piece forty-five, and with the third eighty-five, by the draw-tube these powers may not only be made even numbers, as forty, fifty, and ninety, but all intermediate numbers, if required, may be obtained without changing either the eye-piece or the object-glass. Besides this, it is often required to make a particular object fill the whole or nearly the whole of the field of view, this is readily

* Art. “Microscope,” *Cyclopædia of Anatomy and Physiology*, p. 342.

done by employing the eye-piece and object-glass that most nearly effect it, and then to accomplish the remainder by drawing out the tube. In the use of the micrometer eye-piece, the draw-tube will also be found of essential service to make the divisions come out whole numbers, a point that will again be more particularly dwelt on.

PART II.

USE OF THE MICROSCOPE.

USE OF THE MICROSCOPE.

CHAPTER I.

PRELIMINARY DIRECTIONS.

ALL the most complete forms, both of simple and compound microscopes, constructed by our principal makers, together with the optical and other apparatus supplied with them, having now been fully described in the first part of the work, it becomes necessary to enter in detail into the different modes of using the same. And as the compound instrument is of more general importance and more difficult to use than the simple form, it must first claim our attention. But for the better understanding of the different steps in the proceeding, it has been deemed advisable to describe them under separate heads.

Position.—If day-light is to be employed as the illuminating agent, the spot selected for planting the microscope on should be in all cases a firm steady table, near a window that is not at the time exposed to the direct rays of the sun, a white cloud immediately opposite to the sun is the point from which the most intense light is given off, and a dark cloud or blue sky in the same situation is that from which the fewest rays proceed. If the instrument is to be used at night, it matters not where the table is placed, but the choice of an illuminator then becomes necessary. This most commonly is an Argand oil lamp, but a wax light or that of gas or camphine may supply its place. The microscope having the mirror and the rest of the optical part free from dust, being placed upon the table, and an eye-piece having been slid into one end of the compound body, and an object-glass screwed into the other,

must now have the compound body inclined to such an angle as will bring the top of the eye-piece opposite the eye of the observer when sitting in the most easy posture. The next step is the adjustment of the light.

Adjustment of the Light.—If it be required to examine a transparent object by day, the light must be taken from a window as free from bars as possible; but if at night, then one of the illuminators, previously described, must be brought within a moderate distance of the mirror, this last is to be turned about in any direction, until the light reflected from its surface be seen to pass through the hole in the stage, and to fall in the direction of the axis of the instrument upon the end of the object-glass; then, by applying the eye to the eye-piece, and moving the mirror very slightly one way or the other, the maximum of light will be obtained; but if the object to be examined be opaque, and if the Lieberkuhn, fig. 66, is to be employed, the lamp may be placed in the same position as for a transparent object, but if required to be illuminated by either of the condensing lenses represented at page 106, then the lamp must be brought nearer to the observer, and the light thrown upon the object by placing the condenser between it and the lamp, in the manner presently to be shown by diagrams. As a general rule, it is best to use the low powers first, as a good light and greater clearness of definition, together with a large and flat field of view, will be obtained; the higher powers may be employed when the observer has a good general idea of the arrangement of the several parts.

Transparent Objects.—These, previous to being examined, are to be placed either with or without water upon a slip of glass, and covered with a piece of thin glass or mica, or, if required, either of the animalcule cages or compressors, described at page 116, may be employed for the same purpose. Between which ever of these pieces of apparatus the object is contained, the next proceeding is to place it upon the object-plate of the stage, and having so adjusted the latter, either by sliding it up or down, or by acting on it by the stage movements, that the object, if visible to the naked eye, may be

brought as near to the axis of the object-glass as possible. We now come to the adjustment of the focus.

Adjustment of the Focus.—If the focal distance of the object-glass be known, then, without looking through the compound body, it may be brought down as near to the focus as possible, by turning the large milled head of the coarse adjustment, and the eye being applied to the eye-piece, the proper focus may be obtained, by carefully noticing when either the object or some of the extraneous bodies generally found either upon the glass or in the fluid come into view. If the power employed be a high one, it is always best to bring the object-glass as near as possible to the focus with the coarse adjustment, and to use the fine afterwards when the eye is applied to the eye-piece. If the object be not in the field of view, then the glass or other apparatus on which the object is placed is to be moved about by the stage adjustments until it appears there, or, in the absence of stage movements, the fingers themselves must be employed. When the object is of any thickness, it will be readily found that by the use of the fine adjustment, any part, whether of the upper or of the under surface, may be brought into focus; and if it should be transparent and cylindrical, like some of the vascular tissues of plants, the markings on the vessels may be traced all round the cylinder, and if the milled head of the adjustment be graduated, as in the instruments of Messrs. Smith and Beck, then one revolution of the milled head will either raise or depress the object-glass about the $\frac{1}{150}$ of an inch, and if the divisions amount to ten, then the value of one division will be the $\frac{1}{1500}$ of an inch, so that the thickness of any object of this minute size can be very well ascertained; a plan of measuring that was first adopted by Mr. Valentine in the microscope, described at page 61. By this contrivance, also, certain pits or depressions in any object can be accurately measured, by bringing first the upper or plane surface into focus, and then noting how many revolutions or parts of a revolution are gone through before the bottom surface is also correctly defined; the graduation of the milled head will also be found of great service for properly adjusting the front lens of the higher power object-glasses, as

the thickness of the thin glass cover can be accurately measured, and the object-glass corrected by certain rules presently to be laid down. When any object has been under examination, and it has become necessary either to remove it from the stage for some alteration, or to substitute another in its stead, it will be found by far the best plan, if the object-glass be of short focus, to turn it back from the object before removing it, by this means all contact between it and the object will be necessarily prevented; as often, either by the removing of the object or the substitution of another, when the object-glass is of short focus, all risk of injury will be avoided. After a few trials the custom of turning back the object-glass by the coarse adjustment will become habitual.

Various re-agents, such as the acids or alkalies, may be applied to objects when they are being viewed, by touching the edges of the glass cover with a small glass rod or tube that has been dipped into the required fluid. A small quantity will gradually insinuate itself between the glasses, and its effects can be easily watched. When a large quantity of a corrosive fluid is required, or if the object in fluid be not firmly secured between the two glasses, it is advisable to place the microscope upright, as then all danger of losing the object, or of having the fluid escape about the stage, will be in a great measure avoided. The glasses between which objects are placed should be perfectly free from grease, if not so, when the water or other fluid is added, it will not run equally between the glasses, and large air bubbles will be formed, all of which should be got rid of, especially if they are in the neighbourhood of the object, as they act like so many lenses, and occasion a disturbance in the rays of light that are passing either through or about them.

Small living insects may be viewed in the live box or the animalcule cages by transmitted light, and those that are large, such as flies, may even be held in the forceps, and the circulation in their legs readily seen, no glass being placed beneath them.

When the highest powers are required, the light of the day or of a lamp may be greatly increased by the use of the achro-

matic condenser, described at page 100, especially if the light be first thrown on the mirror by the bull's-eye condensing lens, full directions for the use of which will be given in the following chapter.

Opaque Objects.—These are illuminated either by the bull's-eye condensing lens, the Lieberkuhn, or the side reflector, and the object-glasses employed cannot exceed the one-fourth of an inch, as no higher magnifier is provided with a Lieberkuhn, and the light from the condensing lens or side reflector cannot be thrown upon any opaque object that has the object-glass nearly approaching it. Opaque objects are generally mounted, either on slips of glass or on discs of card or other material, having a pin passed through them; these require to be held in the forceps, described at page 113, and if the Lieberkuhn be employed, the diaphragm plate under the stage must be removed, and the light thrown upon the Lieberkuhn by the concave mirror in the same manner as was described for a transparent object, the lamp or other illuminating agent being placed either in front or on one side of the mirror. If the microscope be inclined, and it be required to illuminate an opaque object by the condensing lens, the lamp must then be brought near to the eye of the observer, and the condenser placed between it and the object; the distance between the lamp and the condenser being in all cases greater than that between the condenser and the object, otherwise the rays of light will not be made to converge upon the object. If the disc or glass on which the object is mounted, or even if the object itself be not large enough to cut off the light from entering the object-glass, then a dark stop or well, represented by fig. 68, must be employed to form a back ground to it. The method of using the stops and all the other illuminating apparatus must now be more fully entered into, but it will be necessary for those who are about to use the microscope for the first time, to pay particular attention to the directions just now given, as their future progress in manipulation will be much facilitated by so doing.

CHAPTER II.

ON THE ILLUMINATION OF OBJECTS.

ALL the objects required to be examined by the microscope belong to one of two classes, either the transparent or the opaque. The methods of illumination differ for each class, in the former the light is generally reflected upon them by means of a plane or convex mirror, whilst in the latter it is either condensed upon them by a lens or else by some modification of the silvered cup, termed, from its inventor, the Lieberkuhn. As the perfect illumination of objects is of the utmost importance, nay, almost as essential as a good glass to examine them with, it will be necessary to enter somewhat in detail into the various plans that must be adopted, in order that all the true characters present, in any given subject under investigation, may be brought out and rendered perfectly distinct. In order to effect this, it is requisite that it be viewed alternately under every description of light, whether strong or faint, oblique or direct; or whether the light be reflected through it from a mirror, as in the case of a transparent object, or be condensed upon it by a lens as for an opaque; in short, every new subject should be viewed under all the various conditions which will subsequently be enumerated.

Transparent Objects.—Where a great amount of light is required, the plan generally adopted is to use the concave mirror, which should be so contrived as to slide up and down upon a stem, so that it may be brought close to the stage or be slid away from it, and by means of a universal joint be made capable of being turned in every direction; when rays of light from a lamp or candle fall upon a concave mirror, they are rendered convergent, and the distance of the mirror from the stage should, therefore, be so regulated that, if required, the whole of the light reflected from the mirror may be brought to a focus upon the object, or if a weaker light be necessary, then by sliding the mirror either nearer the stage or farther away from it, the desired light will be obtained. In

both these cases there will be a larger field of view illuminated, but with a great diminution of its brightness, hence the use of the mirror being made to slide. For all objects of large size, such as sections of wood, mosses, the wings of insects, &c., where low powers only are required, the illumination may be effected by the concave mirror, which, for the purpose, should not be less than two inches in diameter. Nothing is more simple than to illuminate a large object, but it will be found, when high powers are used, that considerable difficulties will prevail, and it is important that all the light possible should be made available for the purpose, it becomes necessary therefore to have recourse to the other optical contrivances presently to be described.

To cut off all superfluous light, an apparatus termed the diaphragm, described at page 99, fig 49, is generally fitted to the under side of the stage; it is supplied with a moveable plate, in which there are three or more holes of different sizes, each of these in succession may be brought between the mirror and the object, and it will be found advisable to try by which of the apertures the best definition is effected.

Some persons recommend the interposition of a plate of ground-glass between the mirror and the object, to diffuse the light equally over the field, and to destroy all the glare occasioned by the reflection of a large body of light, but this is only applicable to objects of large size, where low powers are used. When applied to the higher powers, and to objects which require to be well defined, the field of view is then rendered so misty, that all sharpness of outline is destroyed. In this case a very great improvement is effected if the ground surface of the glass be made greasy, which allows more light to be transmitted. Another way of softening the glare is to supply the place of the ground-glass with glass of a neutral or blue colour, this is recommended to destroy the reddish-yellow colour given off from all luminous bodies, and to make the artificial light as pleasant to use as that of the natural or daylight; but none of these appliances should be used with high powers, or where accurate definition is necessary, as in the

case of test objects. It will be found useful to have a piece of neutral tint glass fastened into the diaphragm-plate, as described at page 100. That it may be always at hand when required.

The plane mirror, with some form of condensing apparatus, is required with all powers above that of a hundred linear, when it is wished to examine very delicate objects by artificial light; for this purpose the form of condenser first recommended by Dr. Wollaston for his doublet microscopes, and described in pages 30 and 100, will be found very advantageous; it consists of a tube, in which a plano-convex lens, of three-quarters of an inch focus, is made to slide up and down within certain limits. This tube is fitted to the under part of the stage, and at its lower end is provided with a plate of metal, perforated with a hole of a requisite size, termed a stop; the rays of light reflected from the mirror, if taken from a white cloud, being parallel, will be thrown upon the lens as such, and by it be brought into a focus upon the object; this is effected by sliding the lens either up or down. Most objects are best seen when the image of the aperture or stop is also best seen. When artificial light from a lamp or candle is employed, the rays which fall on the mirror may be rendered parallel by placing the bull's-eye or condenser in front of the flame with its flat surface nearest to it, the lamp itself being placed at least a foot distant from the mirror.

Dr. Goring effected an improvement on Dr. Wollaston's condenser, by putting the stop above the lens, so that it might be near to the object; by these means the rays of light are brought to a focus on the object, and all the superfluous ones are cut off by the stop, but if the original tube be preserved, the stop above the mirror may still be used, the one immediately above the lens being in no way interfered with by it. Mr. Varley has recommended* a very excellent plan for imitating artificially the light reflected from a white cloud opposite the sun; this is by covering the surface of the mirror under the stage with carbonate of soda or any other white

* Vol. xlix., page 353, of *Transactions of the Society of Arts.*

material. On the surface of this the light of the sun is to be concentrated by means of a large condensing lens. The light so reflected is very intense, and forms an excellent substitute for the white cloud, which, as Mr. Ross states,* when opposite the sun, and of considerable size, is the best day-light, as the pure blue sky, in the same situation, is the worst.

Sir David Brewster, to whom we are indebted for so many valuable suggestions and discoveries in optical science, states† that, for perfect definition, the focus of the illuminating lens for transparent objects should fall exactly upon the object, so that there shall not be two sets of rays at different angles, one proceeding from the luminous body, and the other from the object to be magnified; and adds,—“That the illuminating lens should be perfectly free from chromatic and spherical aberration, and that the greatest care should be taken to exclude all extraneous light, both from the object and from the eye of the observer.” All this implies that the condenser employed should be in itself achromatic, for an ordinary lens acting more or less as a prism to decompose the light, it follows that in most cases we shall have the object illuminated with the prismatic colours, and all sharpness of outline at once destroyed. Hence the necessity of employing a doublet or some kind of achromatic lens for a condenser.

Achromatic Condenser or Eclairage.—This instrument, the invention of M. Dujardin, an eminent French microscopist, has been previously alluded to; the different forms of it, supplied with our best microscopes, are represented by figs. 51, 52, 53, and although differing slightly from each other in their construction, they all, nevertheless, are capable of being so adjusted for use, that the axes of the illuminating lens and object-glass may accurately coincide with each other. The means provided for effecting these adjustments are represented by the figures, but in order to facilitate their use, Mr. Ross has drawn up a series of directions, which being applicable to other microscopes, as well as his own, I venture here to quote in full:—

* *Penny Cyclopædia*, Art. Microscope.

† *Treatise on Microscope*, p. 146.

“When employing this apparatus, the general practice is to insert in it, as an illuminating lens, the object-glass next lowest in power to that which is intended to be attached to the microscope; so that when the one-eighth is used on the microscope, the one-fourth is screwed into the illuminating apparatus, and so, in like manner, with the rest. But when economy is not regarded, a system of three achromatic combinations is supplied, adapted for the illumination of the whole range of the powers of the microscope, the whole system being employed for the highest powers, two of such combinations with the middle powers, and the largest combination by itself, for the lowest powers. This illumination is not required for objects when viewed with object-glasses transmitting small pencils of rays, or whose angular aperture is less than thirty degrees—that is, where the object-glass is of greater focal length than half an inch.

“The apparatus is fixed to the underside of the stage of the microscope, in the place of the diaphragm plate; and before fixing, the proper object-glass, as an illuminating lens, must be screwed on to it. Place the object to be viewed upon the stage of the microscope; and when the instrument is not directed at once (as after noticed) to the source of light, such as the flame of a lamp or a white cloud, arrange the reflector (having the plane mirror upwards) so as to throw the light up the tube of the apparatus; which may be ascertained by turning aside the microscope tube, and observing when the spot of light appears on the object placed on the stage. The microscope tube is then to be replaced, as nearly over the spot of light as possible, and vision of the object obtained, disregarding the precise *quality* of the light.

“The two following important adjustments must next be effected:—first, make the image of the source of light (as flame of lamp or light cloud) distinctly seen at the same time that the object on the stage is seen; and, secondly, make the axis of the tube of the illuminating apparatus coincide with that of the tube of the microscope. The first adjustment is accomplished by turning the milled-head screw on the side of the tube of the apparatus, until the brightest illumination

is seen through the microscope; then move the microscope tube from its central position sideways across the spot of light and back again, to ascertain if the spot of light passes across the centre of the field of vision; if not, it may be corrected by turning the milled-head screw of the illuminating apparatus which presses against the front edge of the stage, and when, by adjustment, it is found that the spot of light passes centrally across the field, then, having adjusted the microscope tube so as to bring the spot of light to the centre of the field of vision, screw the microscope tube fast in its place. To effect the second adjustment mentioned above, the mirror must be moved about until an image, more or less distinct, of some adjacent object—such as a window-bar or chimney-pot—crosses the field of the microscope; the most distinct vision of this object is then to be obtained by turning the milled-head screw on the side of the illuminating apparatus, the microscope tube remaining stationary with the object in its focus. When these general adjustments are accomplished, the whole may require correction, which must be effected by a repetition of the process. The mirror may then be turned up to the sky, that being the source of light, and its best state for illuminating microscopic objects is by means of white clouds opposite the sun. The utmost perfection of vision is generally obtained by this adjustment for day-light illumination upon delicate objects; but by lamp-light these objects are sometimes seen best by placing the achromatic illuminating lens a little nearer the object than the distance which produces a distinct image of the source of light, at the same time that the object is in focus. Objects having some little thickness are best seen when the lens is a little farther off than the distance just mentioned. This last position of the illuminating lens diffuses the light more equally over the field.

“When lamp-light is used, an object-glass of lower power than that which it is intended to employ for observation, should be applied to the microscope tube, and the adjustment performed as before directed. Attention must be paid to this additional circumstance, namely, that the image of the lamp

be placed in the middle of the illuminated disc of light, by means of the mirror; the mirror and lamp are then to remain stationary. But if the mirror should not be employed, and the light obtained direct from the lamp, then, in order to throw the image of the lamp in the middle of the illuminated disc, the adjustment must be made by a lateral movement of the whole microscope, and by varying its inclination; the image being thus found, the lamp and microscope must remain stationary. The object-glass used in this preliminary adjustment is to be removed, and the object-glass to be employed for observation is then to be screwed on to the microscope tube in its place, and the object brought into focus, which will also bring the image of the flame of the lamp distinct; but the distinctness, as also the centricity of the image of the flame, may have been in a degree deranged by slight differences in the screws of the object-glass and other minute circumstances. This deviation is to be rectified by moving the microscope tube sideways and back again across the image of the flame, and, if adjustment be necessary, by turning the milled-head screw which presses against the front edge of the stage, as before described, while the mirror and lamp remain stationary. Slight obliquity of the illumination subdues the glare attendant upon perfectly central and full illumination by lamp-light; and this obliquity may be obtained by slightly altering the position of the mirror; or if the mirror is not employed, but light is obtained by pointing the microscope tube directly to the lamp, then the obliquity required may be obtained by a small variation of the inclination of the microscope."

Some achromatic condensers are provided with a prism of the form represented by fig. 90, as a substitute for the plane mirror. M. Dujardin employed it with his condenser, and the first of these instruments brought to this country was supplied with one. The method of using it differs so little from that of the ordinary mirror, that no especial directions need be given. The prism certainly has some advantages over a mirror in bringing out minute markings, and also in being a better illuminator.

Mr. Varley's dark chamber has been already described at page 100, it is very useful where an achromatic condenser is not supplied, as the light, having no lens to pass through, is not decomposed, in this consists its value; the method of using it being similar to that of the achromatic or Wollaston's condenser, a separate description is not required in this place.

Direct Light.—Many very delicate objects may be seen to the greatest advantage by what is termed *direct light*, which is obtained readily by the removal of the mirror, and by placing a lamp or candle behind the stage in its stead; for this purpose it will be necessary to incline the microscope, so that the rays may pass through the stage; and in order that the posture in which the observer must be placed be not rendered fatiguing, it is the best plan at first so to raise the instrument from the table, that the eye-piece may be on a level with the eye. In the day time, the light taken directly from a white cloud opposite the sun will serve to bring out some objects very beautifully, but it is impossible to give a list of those that are best shown by direct light, this can only be known after very extensive practice, as the effects will vary with each different magnifying power.

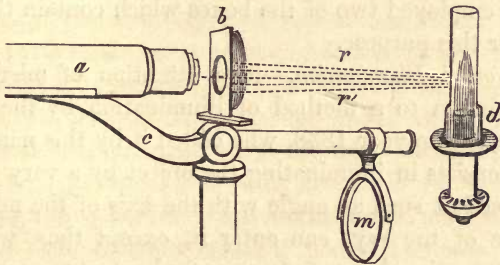

Fig. 111.

Fig. 111 represents the method of illuminating by direct light. *a* is the compound body, placed in a horizontal position, having the stage *b* at right angles to it; the mirror *m* is turned on one side, so that the diverging rays *r r'*

emanating from the lamp *L*, may pass through the hole in the stage in nearly straight lines; the same position of the instrument will sometimes answer for daylight, but it will be generally found that, to get the brightest light, the compound body must be more depressed. If the lamp employed as the illuminator can be slid down so far, that the end of the burner nearly touches the table, or if a short piece of wax candle be used, the compound body may be inclined at an angle the most easy for the observer to work at; the inclination in all cases must, of course, depend upon the height of the illuminating body from the table on which the microscope is placed.

Oblique Light.—For the perfect definition of the markings of certain fossil animalcules of the genus *Navicula*, very oblique light must be employed, this is effected by placing the microscope in the inclined position, and taking away all the apparatus from the under surface of the stage, such as the diaphragm-plate, or achromatic condenser, and by turning the mirror so far on one side, that the rays of light may be thrown, as it were, obliquely across the object, and not perpendicularly through it. When the mirror cannot be turned very far away from the centre of the stage, the desired effect may be obtained by mounting the object upon something that will raise it some distance above the general level of the stage. Mr. Anthony employed two of the boxes which contain the object glasses for this purpose.

Background Illumination.—The attention of microscopists was first drawn to a method of illumination by the Rev. J. B. Reade, in the year 1838, who called it by this name. The method consists in illuminating the object by a very powerful light, placed at such an angle with the axis of the microscope that none of the rays can enter it, except those which fall directly upon the object, and are so far bent as to pass through it into the compound body. For the better understanding of the mode of effecting this illumination, fig. 112 has been drawn to give a general idea how the microscope and the other apparatus are to be placed for the purpose:—*a b* represents the stage of the microscope in an inclined position; *c* a condensing lens placed below and on one side of the

stage; *d* a lamp also placed below the stage and at some distance from it; the rays of light *r r r' r'* emanating from the lamp,

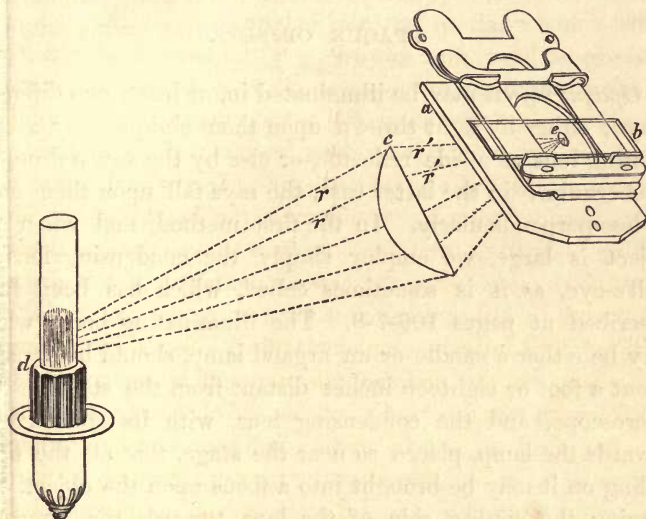

Fig. 112.

are thrown obliquely upon the object *e*, and only those that are refracted by the glass, or by the object under examination, will pass through the compound body to the eye: some objects, when viewed in this way, will appear beautifully illuminated on a field of view that is nearly, if not quite, dark. This is a most valuable method of illumination for some preparations, but not for others; hence, in all newly investigated structures, it should be employed to see what effect it produces on them. It is also capable of being accomplished by daylight by elevating the condenser *c* above the stage, and then allowing the rays from a white cloud, if possible, to pass through it; but the effect is not quite so striking as when a lamp is employed, unless the eyes be shielded by the hood or bonnet, described at page 132, from all the surrounding light. These different modes of illuminating transparent objects will be again alluded to in the chapter devoted to test objects.

CHAPTER II.

OPAQUE OBJECTS.

Opaque objects may be illuminated in, at least, two different ways; either by light thrown upon them obliquely by a condensing lens or a side reflector, or else by the silvered cup or Lieberkuhn; in the latter case, the rays fall upon them more or less perpendicularly. In the first method, and when the object is large, we employ simply the condensing lens or bull's-eye, as it is sometimes called, which has been fully described at pages 106-7-8. The illuminating body, which may be either a candle or an argand lamp, should be situated about a foot or eighteen inches distant from the stage of the microscope, and the condensing lens, with its convex side towards the lamp, placed so near the stage, that all the light falling on it may be brought into a focus upon the object. By turning the convex side of the lens towards the lamp, as shown in fig. 113, in which A B represents the stage; C the

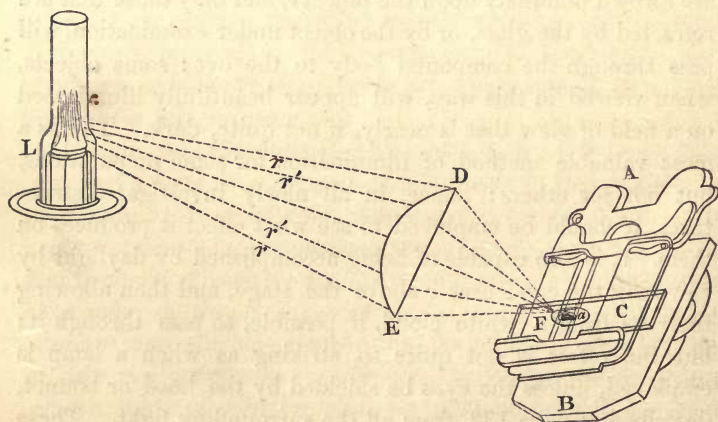

Fig. 113.

glass plate supporting the object *a*; D E the condensing lens; L the lamp; and *r r' r r'* diverging rays of light falling upon

the lens D E; these rays, as also those shown by fig. 100, will be brought into a focus F, when the lens is placed as there represented; but if the flat side occupy the same position, then, according to fig. 101, it will be in the worst possible condition, as its spherical aberration will be the greatest. Fig. 114 represents this arrangement, the same letters being used as in the preceding figure; here it will be seen that the

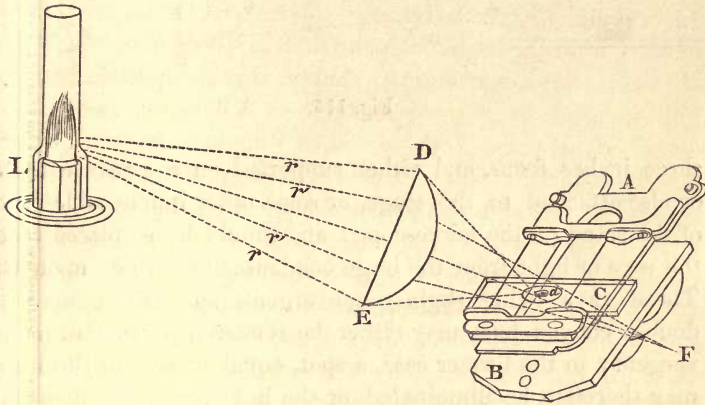

Fig. 114.

rays nearest the margin of the lens D E will be brought to a focus upon the object *a*, but those nearer the centre will pass on to F, so that *a* will be only illuminated to about one-half the extent of *a* in the preceding figure. When, however, it is required to procure either parallel or diverging rays, so as to illuminate a large surface, such as the mirror or side reflector, the lens must then be placed very near the lamp with its flat side towards the light, as shown in fig. 115, and, according to the distance of the one from the other, so will the rays either be convergent, divergent, or even parallel. Should it be required to illuminate a large portion of an object for dissection or for other purposes, then we may have recourse to the following plan; the large condenser must be placed near to the lamp, so that diverging rays given off from it may be so converged as to fill the entire

circle of the small condenser, before described at page 108; this, generally speaking, is a double convex lens of two or

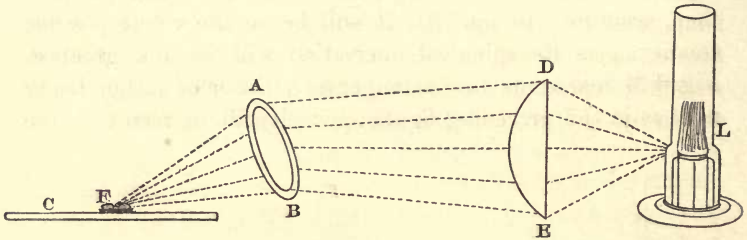

Fig. 115.

three inches focus, and either supported on a separate foot, or else attached to the stage, or some other immoveable part of the stand of the microscope; and should be so placed that the rays of light from the large condenser be thrown upon it. These rays being slightly convergent, and falling upon a double convex lens, may either be rendered parallel or convergent; in the former case, a spot, equal in size to the lens, may therefore be illuminated, or the light may be brought to a focus F upon the object C, as seen in fig. 115, where L represents the lamp; D E the large condenser; and A B the smaller. The small condenser answers uncommonly well for daylight, for, in this case, the rays being parallel, they will be made to converge and be brought into focus upon the object. This mode of illuminating an opaque object appears to have been first contrived by Hooke, in 1675, for, in his *Micrographia*, plate 1, the same arrangement is represented as the one above described; but, instead of a large condenser, a globe of glass full of water was used by him.

The other mode of illuminating an opaque object by oblique light is that by the side reflector, the invention of Mr. Ross, it consists of a hemispherical oblong silver cup, described at page 104, which is attached to some immovable part of the stage or the stand of the instrument, and is supplied with a sliding arm and a ball and socket joint for adjustment, so that it may be used for an opaque object either

placed on the stage, or held by the forceps; the mode is as follows:—

The condensing lens, being placed near to the flame of the lamp, must be arranged to throw parallel rays upon the reflector, which should be so adjusted as to condense them upon an object placed in its focus. The manner of doing this is shown by fig. 116, where AB represents the reflector; C a

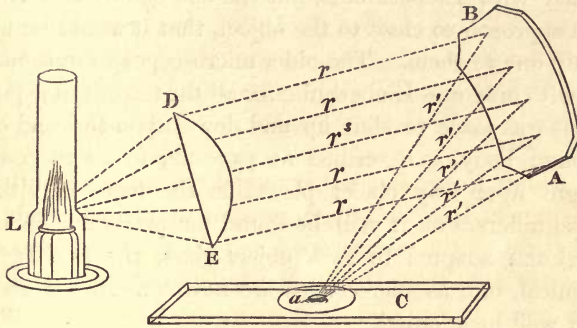

Fig. 116.

glass slide, supposed to be on the stage-plate of the microscope, with an object *a* upon it; L the lamp, the burner of which should be on a lower level than the reflector; and DE the condensing lens placed at a short distance from the flame of the lamp, the diverging rays given off from it are rendered nearly parallel by the lens, and the five rays *rr*, &c., falling on the reflector, become convergent as seen *r'r'*, and, as such, meet in a focal point on the object *a*. The reflector being attached to some immoveable part of the microscope stand, and the lamp and condensing lens being also fixtures, it follows that the object, if large and flat, may be moved by the stage adjustments into any position that may be required without the least alteration of the reflector; but should the object have an uneven surface, the reflector may then be so turned on its ball and socket joint, as to suit every inequality the object may present.

Lieberkuhn.—The mode of illuminating by perpendicular light is effected by the Lieberkuhn, before described at

page 111; this consists, as there stated, of a concave silvered cup, adapted to a short tube that slides over the outer part of the setting of the object-glass with which it is intended to be used; and is so contrived that, when converging rays of light are thrown on it by the concave mirror, they will be brought to a focus on an object placed in the focus of the object-glass. All the object-glasses, from the two inch to the one-fourth, are provided with Lieberkuhns, but the one-eighth and one-sixteenth approach so close to the object, that it would be useless to apply one to them. The older microscopes were sometimes fitted with only one Lieberkuhn for all the magnifying powers, and this was made to slide up and down upon the end of the compound body, as described at page 22, so as to condense the light upon any object placed in the focus of either of the magnifiers, but it will be found far preferable to have a Lieberkuhn adapted to each object-glass, the old way was economical, but, as microscopes are now constructed, the plan cannot well be adopted.

When it is required to use a Lieberkuhn, the diaphragm plate should be removed from the under surface of the stage, and an object-glass, with its accompanying Lieberkuhn, having been screwed to the compound body, the object intended to be viewed must either be placed on the stage-plate or held in the forceps; the light must then be thrown upon the Lieberkuhn by the concave mirror, as shown in figs. 117 and 118, where A represents the end of the compound body, B the object-glass, C the Lieberkuhn in section, D the concave mirror, and E an object in the focus of the object-glass. The converging rays rr , &c., reflected from the mirror, will be condensed upon the object E, which, if perfectly flat, will be well exhibited; but if the surface is uneven, no part of it will be correctly defined, in consequence of there being no shadows. The method of illuminating then to be employed is shown by fig. 118, where it will be seen that the rays rr , &c., from the mirror, are only thrown on one side of the Lieberkuhn C; these are reflected obliquely upon the object E, and no part of it being illuminated perpendicularly, a shadow is therefore produced, and a correct figure obtained. If the

object be a transparent one, it is necessary that some kind of dark ground be placed at the back of it, to prevent the central

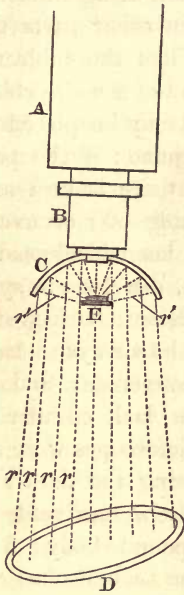

Fig. 117.

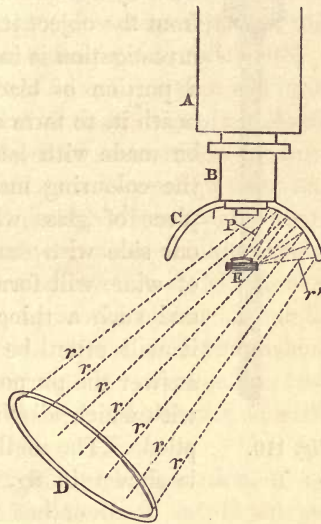

Fig. 118.

rays of light from passing to the object-glass: this may be effected by the employment of one or other of the dark stops or chambers, represented by fig. 119, which should be brought into the axis of the instrument, so as to cut off all the rays that otherwise would pass to the object-glass, and so interfere with the definition, as it is highly necessary that no rays should pass to the magnifier, save those from the object itself. These stops are made of different sizes for the different magnifying powers; the lower the power the larger the stop required. When the stops are not fitted to a microscope, their place may be supplied by a disc of black paper laid behind the object; or if the preparation be mounted either on the discs of cork or in cells, as hereafter to be described, the use of the dark stop may be dispensed with. Many persons prefer mounting their opaque objects on papers of different

colours, such as green, red, and even white; but it will be found by far the best plan to use a dead black, as then there is no danger of the definition being interfered with by light reflected from other parts than from the object itself. When the subject of investigation is in fluid, and of a white colour, a portion of black paper may be placed beneath it, to form a back-ground; if the paper be made with lampblack, there is no fear of the colouring matter coming off; or even a piece of glass which has been blackened on one side with sealing-wax, dissolved in spirits of wine, will form an excellent back-ground, and such a thing should be always at hand; it will often be found convenient, and will answer the purpose of the black circular disc with which all the old microscopes were supplied. The method of using the dark stops is shown in fig. 120, where *a* represents the end of the compound body; *b* the object-glass; *c* the Lieberkuhn; *e* the dark stop, which is to be placed in the hole of a small arm, that is capable of being turned under the stage after the diaphragm has been removed; *f* a pair of forceps, in which is held the object *d*. The rays reflected in nearly parallel lines from the mirror are by the Lieberkuhn concentrated on the object, and those which are near the centre are prevented from passing into the object-

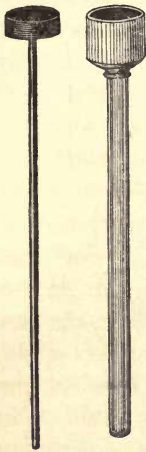

Fig. 119.

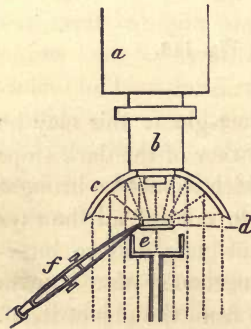

Fig. 120.

glass by the dark stop *e*: it little matters how small the object is, or whether it be transparent or not, as the dark stop will entirely prevent any light passing either through or around it.

When the side-reflector and the Lieberkuhn are compared together, it will be seen that, with the latter, all opaque

objects must be under a certain size, otherwise no light will pass around them to reach the Lieberkuhn; but, with the former, it matters not how large they may be, as the light is thrown down obliquely upon them, in the same manner as if the condensing lens were employed. As a general rule it may be stated, that the side-reflector is most useful with powers up to the half-inch, the Lieberkuhn with the higher.

It must be borne in mind that those objects in which rich tints of colour prevail, or others whose surfaces in any way decompose the light, must be mounted in such a manner, that they may be turned in every possible direction, in order that the rays of light may fall on them at very oblique angles; a disc of card or cork, with a pin through it, will be the best plan to adopt, as then they may be inclined at any angle, either by turning the pin or shifting the forceps in which the pin is held. The mounting on flat slips of glass, as shown in figs. 113-14-15, cannot be advantageously employed with any of such objects.

Before leaving the subject of the illumination of microscopic objects, it may be as well here to lay down certain rules, which, for the accurate display of minute structures, should be fully carried out. Sir David Brewster,* the greatest living authority in these matters, has insisted on the following; these, with some few alterations suitable to our modern microscopes, we will adopt:—

1. The eye should be protected from all extraneous light, except that which is transmitted through or reflected from the object.

2. Delicate microscopical observations should not be made when the fluid which lubricates the cornea of the observer's eye happens to be in a viscid state, which is frequently the case.

3. The figure of the cornea will be least injured by the lubricating fluid, either by collecting over any part of the cornea, or moving over it, when the observer is lying on his back or standing vertically. When looking downwards, as into the compound microscope arranged vertically, the fluid

* *Treatise on the Microscope*, p. 138.

has a tendency to flow towards the pupil, and injure the distinctness of the vision.

4. If the microscopic object is longitudinal, like a fine hair, or consists of longitudinal stripes, the direction of the lines or stripes should be towards the observer's body, in order that their form may be the least injured by the descent of the lubricating fluid over the cornea.

5. The field of view should be contracted, so as to exclude every part of the object, excepting that which is under immediate examination.

6. The light which is employed for the purpose of illuminating the object should have as small a diameter as possible. In the day time it should be a single hole in the window shutter of a darkened room, and at night it should be an aperture placed before an argand lamp. To effect this last desirable object, either the diaphragm represented by fig. 63, or the chimney shade described at page 137, may be employed.

7. In all cases, and particularly when very high powers are requisite, the natural diameter of the light employed should be diminished, and its intensity increased by optical contrivances.

8. When a strong light can be obtained, and, indeed, in almost every case, homogeneous light should be thrown upon the object; this may be done either by decomposing the light with a prism, or by transmitting it through a coloured glass, which has the property of admitting only homogeneous rays. Sir David himself obtained homogeneous light by the employment of a lamp, in which diluted alcohol was burnt; but the cost of the spirit, and the trouble of adjusting the proper colour of the flame, have been a complete bar to its general use.

The two last rules may now be carried out to the fullest extent in all our modern microscopes, by the application to them of the achromatic condenser, and by the use of the neutral tint, or blue glass, under the stage, to destroy the yellow colour of the illuminating rays. The chimneys of lamps also that are now made of glass of a light blue tint, as described at page 137, render essential service to the illumi-

nation by the nearly complete destruction of the yellow colour of the flame, and by the substitution for it of a bright white light.

CHAPTER III.

MICROMETER.

ONE of the most valuable adjuncts to a good microscope is an instrument termed the *micrometer*, which, as its name implies, is for the purpose of ascertaining the measurement of small objects; for not only is it highly desirable in microscopical investigations to have a means of estimating the exact size of any object under examination, but, in the present advanced state of science, accurate measurements alone oftentimes form the most valuable points of distinction, and from the earliest period of microscopical science, the want of some common standard for comparison has been greatly felt. Leeuwenhoek selected minute grains of sand, as nearly alike as possible, and arranging them in a line, counted the number which occupied the space of an inch: by comparing the subjects of his examination with these, he was enabled to form a rough estimate of their bulk. More modern microscopists have employed for the same purpose the sporules of the *Lycoperdon bovista*, or *puff-ball*. These, which are said to be so small as the $\frac{1}{35000}$ part of an inch, will only answer for the most minute structures; but for those that are larger, the sporules of the *Lycopodium* may be used, their mean diameter being about $\frac{1}{940}$ of an inch. Dr. Jurin* introduced into the field of view small pieces of silver or brass wire, whose diameter he had previously ascertained by coiling it round a cylinder, and observing how many breadths of the wire were contained in a given number of inches, or parts of an inch. Other substances, whose dimensions have previously been made known, such as hair silk and human blood, have all been suggested as applicable to the same pur-

* *Physico Mathematical Dissertations*, p. 45.

pose. As long ago as 1750,* Martin Folkes, then President of the Royal Society, described a plan of Cuff's, of placing a lattice of fine silver, or other wires, in the focus of the eye-glass of the compound body, the individual wires being distant from each other $\frac{1}{50}$ of an inch; these were crossed at right angles by others at the same distance apart, and so contrived as to divide the whole area of the field of view into squares, whose sides were just $\frac{1}{50}$ of an inch in length; and as the image of any object under examination is formed where the micrometer is placed, it follows that such image may be readily measured: this appears to have been the first application of a scale to a magnified image.

Benjamin Martin, also, about the same time † contrived a micrometer for his compound microscopes: this consisted of a screw having fifty threads in the inch, and made to revolve in the focus of the eye-glass; one end of the screw was pointed, and the other was provided with a hand, or index, which could be turned upon a dial, like that of a watch, whose circumference was divided into twenty parts; the value of each division, therefore, was $\frac{1}{1000}$ of an inch. The object to be measured was placed on the stage in the usual manner, and was so adjusted that the image of one of its sides should be, as it were, applied to the point of the screw when the hand of the index was at zero; the number of revolutions and parts of the same that may be made during the passage of the point of the screw to the opposite side of the object will give its dimensions.

The elder Adams employed an instrument of the same kind, which was clamped by a screw to the outside of the compound body, and a needle, acted on by a screw with fifty threads to the inch, was passed through a small hole in the side of the body, so as to be in the focus of the eye-glass; the value of each turn of the screw was known by an index, which pointed to a series of divisions on a circular plate fixed at right angles to the axis of the screw. To ascertain with ease a small part of an inch, a sectoral scale was contrived;

* Baker—*On Microscope*, vol. ii., p.

† *Micrographia Nova*, p. 10.

this consisted of two lines, which formed with each other an isosceles triangle, each of whose sides was two inches long and the base one-tenth of an inch; one side was divided into ten parts, and the transverse measure was such a part of the tenth of an inch as was expressed by the divisions, so that the transverse measure of the first division would be the tenth part of a tenth of an inch, or, in other words, the $\frac{1}{100}$. If the divisions were twenty in number, then the value of the same measure would be $\frac{1}{200}$ of an inch. Adams also contrived a micrometer for placing on the stage; it consisted of a few small silver wires, in the form of a lattice, the distance of one from the other being exactly equal to that of the diameter of the wire itself; the lattice was placed between two pieces of mica, and the object was placed upon the mica, and both it and the lattice were magnified equally. Various other contrivances have been had recourse to for effecting the same object, but they may all be classed under two heads:—first, into those micrometers that are applied to the magnified image of an object; and second, into those that are magnified at the same time as the object itself. It would, however, be useless to enter further in detail into the subject, as only a few of the old forms are now adopted, these being the stage micrometer, consisting of a number of lines accurately ruled on glass, metal, ivory, or mother-of-pearl, after the plan of those of the late Mr. Coventry, and the cobweb micrometer eye-piece of Ramsden; the divided object-glass micrometer, and many others equally good, being now but rarely employed with the achromatic compound microscope. The micrometers in general use at the present day are of three kinds, and may be designated as follows:—first, the stage micrometer; second, the micrometer eye-piece; and third, the cobweb or wire micrometer. The first, or stage micrometer, is placed in immediate contact with the object, and both it and the object are magnified together; whereas the two last are applied to the magnified image of the object, which, in practice, has been found the most available plan.

Stage Micrometer, invented by the late Mr. Coventry, consists of a piece or slip of glass, metal, ivory, or mother-of-

pearl, ruled with fine lines, by means of a diamond point, at some known distance apart, say from $\frac{1}{1000}$ to $\frac{1}{10000}$ of an inch, as shown by fig. 121; on this the object is placed, and it is

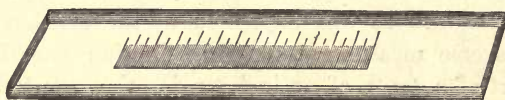

Fig. 121.

necessary that both it and the lines be seen at one and the same time: the number of lines which the object occupies will give the exact measurement. This method, however, is very inconvenient, and can only be effected with a single lens, or with a compound microscope of low power; for with higher powers the focal point is so precise, that the plane in which objects can be distinctly defined is almost a mathematical one, and the lines and the object, therefore, cannot be in focus, or be distinctly seen together; besides, if the object be immersed in a fluid, the lines will become indistinct from being filled with it, and thus the operation of measuring will be rendered almost, if not quite, impracticable. It is also inapplicable to opaque objects of any thickness, and even to transparent ones after they are mounted; but is of great use for other purposes, and will be again alluded to.

Eye-piece Micrometer.—This consists either of a positive or negative eye-piece, having a divided glass placed in the focus of the eye-lens: if the positive eye-piece is used, the divided glass is placed below the field-lens; but if the negative, then the point selected is between the two lenses. The positive eye-piece is the invention of Ramsden, and has been before



Fig. 122.



Fig. 123.

alluded to in pages 73 and 160. Mr. Ross, who employs it for his micrometers, adopts the form represented by the figs. 122 and 123. Fig. 122 exhibits the external appearance, and fig. 123 a section of the same:

it consists of two tubes, sliding one within the other; the external one has the divided glass screwed into its lower end, and the internal carries the two lenses, as shown in fig. 123. When this figure is compared with fig. 91, it will be seen that the field-lens is reversed; that is, its convex surface is towards the eye. The divided glasses are shown by fig. 124;

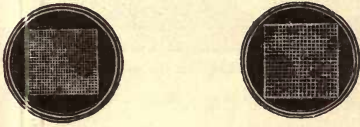

Fig. 124.

the lines ruled on them may vary from the $\frac{1}{25}$ to the $\frac{1}{100}$ of an inch apart; they are set in brass cells, by which they may be screwed into the lower end of the outer tube, so as to

be in the focus of the eye-glass. The value of the squares, with the different eye-pieces, is obtained by a stage micrometer. Mr. Ross now employs only one divided glass, and the values of the squares, with the different object-glasses, having been determined, are set down in a tabular form. Mr. Powell and Mr. Smith, following Mr. Tulley, place the micrometer, in the negative eye-piece, in the situation of the stop. Each of these plans has its peculiar advantages. The positive eye-piece gives the best view of the micrometer, the negative of the object. The former is quite free from distortion, even to the edges of the field; but the object is slightly coloured. The latter is free from colour, but is slightly distorted at the edges; in the centre of the field, however, to the extent of half its diameter, there is no perceptible distortion, and the clearness of the definition gives a precision to the measurement which is very satisfactory. The plan now generally adopted is that which was first recommended by Mr. George Jackson, in a paper read before the Microscopical Society, in 1840; since that time, he has improved upon the method of mounting the divided glass, and has furnished to the society a more lengthened communication, from which, by his permission, I have taken my description.

Short bold lines are ruled on a piece of glass; and, to facilitate counting, the fifth is drawn longer, and the tenth still longer, as in the common rule. Very finely levigated

plumbago is rubbed into the lines to render them visible; and they are covered with a piece of thin glass, cemented by

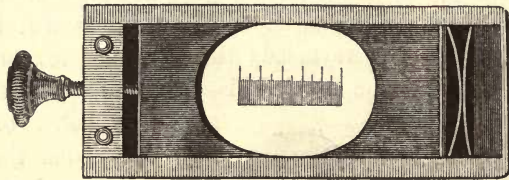

Fig. 125.

Canada balsam, to secure the plumbago from being wiped out. The slip of glass thus prepared is placed in a thin brass frame, as shown in fig. 125, so that it may slide freely; and is acted

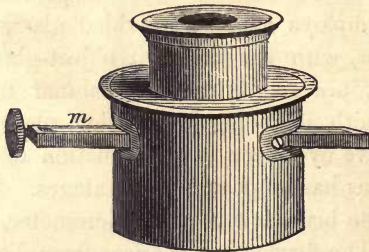

Fig. 126.

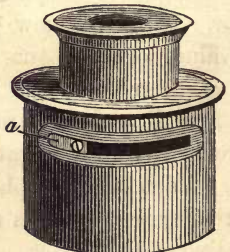

Fig. 127.

on at one end by a pushing screw, and at the other by a slight spring. Slits are cut in the negative eye-piece on each side, as shown in figs. 126 and 127, so that the brass frame *m* may be passed across the field in the focus of the eye-glass, the cell of which should have a longer screw than usual, to admit of adjustment for different eyes. The brass frame is retained in its place by a spring within the tube of the eye-piece. When the frame is not employed, an inner piece of tube *a* may be drawn across the slits, so as to prevent dust from getting between the glasses. The method of using this micrometer is as follows:—the object is brought to the centre of the field by the stage movement, and the coincidence between one side of it and one of the long lines is made with great accuracy,

by means of the small pushing screw that moves the slip of glass; the divisions are then read off as easily as the inches and tenths on a common rule. The operation, indeed, is nothing more than laying a rule across the body to be measured; and it matters not whether the object be transparent or opaque, mounted or not mounted; if its edges can be distinctly seen, its diameter can be taken. Previously, however, to using the micrometer, the value of the divisions should be ascertained with each object-glass, the mode of doing which will be subsequently explained more fully.

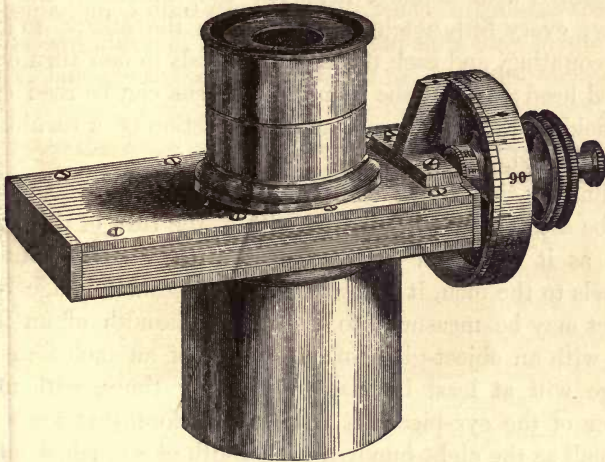

Fig. 128.

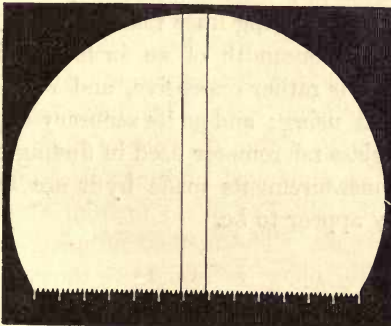

Fig. 129.

The cobweb micrometer, the invention of Ramsden, is represented by fig. 128; it is composed of a positive eye-piece (fig. 91), in the focus of the upper or eye-glass of which two very fine parallel wires, or cobwebs, are stretched across the field; one of these wires can be separated from the other by a screw, commonly provided with a hundred threads to the inch, and the head of which, as shown by fig. 128, is also divided into a hundred parts. The field of view, which is represented by fig. 129, is made flat on its lower border, by means of a comb, made of a thin piece of brass, whose edge is indented with notches, made by the threads of the same screw; every fifth notch is longer than the others, to facilitate counting, and each notch corresponds to one turn of the milled head; so that the number of turns can be read off in the field of the instrument, and the fraction of a turn on the divided head.

Thus, by this simple contrivance, the distance of the wires can be ascertained to the hundredth of the turn of the screw; and, as it has been stated that the screw has a hundred threads to the inch, it follows that the magnified image of an object may be measured to the ten-thousandth of an inch; but, with an object-glass of one-eighth of an inch focus, the image will at least be magnified eighty times, without the power of the eye-piece; it follows, therefore, that a quantity as small as the eight-hundred-thousandth of an inch should be appreciable by such an instrument; but in practice this has been found impossible, as no achromatic power has yet been made, capable of separating lines that are closer together than the one-hundred-thousandth of an inch. This micrometer, when well made, is rather expensive, and requires some considerable care in using; and as its accuracy depends entirely on that of the glass micrometer used in finding the value of its divisions, the measurements made by it are by no means so delicate as they appear to be.

ON THE MEASUREMENT OF MICROSCOPIC OBJECTS.

First.—With the stage Micrometer.—To effect this it is necessary to be provided with a strip of glass, mother-of-pearl, or ivory, on which lines are accurately ruled at a certain fraction of an inch apart, say from the $\frac{1}{100}$ to the $\frac{1}{1000}$ of an inch, as was done by the late Mr. Coventry and Sir John Barton. The most convenient form of micrometer, for all purposes, will be one divided into hundreds, and one of these divisions into ten parts, or thousands; every fifth line should be drawn longer, and every tenth still longer than the others, in order that the number of the lines may be the more easily read off. Those of glass are the best for transparent objects, and the mother-of-pearl, or ivory, for opaques; and, to make the lines more evident, finely levigated blacklead should be rubbed in to fill them up. The subject to be measured is to be laid on the glass, or mother-of-pearl, and both it and the lines must be viewed at one and the same time, with the lowest power that can conveniently be used; the number of the divisions occupied by the object will give the measurement required. *Example:*—Thus, suppose an object occupied ten of the large divisions, its linear measurement would then be $\frac{10}{100}$, which, if reduced to its lowest terms, would be the $\frac{1}{10}$ of an inch; if fifty, then it would measure half an inch; if fifteen divisions, then it would be $\frac{15}{100}$, or nearly $\frac{1}{7}$ of an inch. It follows, therefore, that an object to be measured in this way must be very thin and the power low, in order that it and the lines may be in focus at the same time. This micrometer answers better for the simple microscope than for the compound achromatic instrument, as in the latter the focus even of a low power object-glass is so exact, that but very few objects are so thin as to be seen at the same time as the lines. Most of the objects requiring measurement are those which must of necessity be examined in fluid; this will render the lines on the glass micrometer all but invisible, unless they are very boldly ruled and filled up with some opaque matter.

Mr. Pritchard supplies with his microscopes animalcule cages, on the upper surface of the bottom glass of which, lines are ruled from the $\frac{1}{100}$ to the $\frac{1}{200}$ of an inch apart; these can hardly be seen when the fluid containing animalcules is present, although they are very coarsely ruled; and, with objects of any thickness, all measurements are incorrect, in consequence of the rays of light from the object and the micrometer not being given off at the same angle; so that the object is referred to a point of the micrometer larger than it really is.

Second.—By the Micrometer Eye-piece.—In the description of this instrument, given previously in pp. 192-3, it was stated to consist of a positive or negative eye-piece in the focus of the eye-glass, of which a piece of glass, having short bold lines ruled upon its upper surface, was placed generally $\frac{1}{100}$ of an inch apart, with every fifth longer, and every tenth longer still, to facilitate counting; but it is not necessary that the number of lines in an inch be known, as long as they are equidistant; and let us take, in the first place, the negative eye-piece, as supplied with Mr. Powell or Mr. Smith's microscopes.

To find the Value of the Lines in the Negative Eye-piece Micrometer.—The micrometer set in its brass frame, as seen in fig. 125, is passed so far through the slits in the eye-piece, as that the lines may be seen to occupy the centre of the field of view, and to be in the focus of the eye-glass. The eye-piece having been placed in the end of the compound body, as far as it will go, the next step is to determine the value of the divisions of this eye-piece micrometer with each of the object-glasses. This is done by laying on the stage of the microscope a glass micrometer, divided, say into $\frac{1}{100}$ and $\frac{1}{1000}$ of an inch, and the lowest object-glass being screwed to the compound body, the lines on the stage micrometer are to be brought into focus; and either the eye-piece or the stage micrometer having been so turned as to bring the lines in both micrometers parallel, we must then observe how far the lines in each coincide, whether every third, fourth, fifth, and so on; and, for the sake of simplicity, let us suppose the one-

inch object-glass to be employed, and it having been noticed that every division of a hundredth of an inch in the stage micrometer coincides with ten in that of the eye-piece, it follows that the divisions or lines, in the eye-piece micrometer, were $\frac{1}{1000}$ of an inch apart; the stage micrometer may now be removed, and every object viewed with the micrometer eye-piece and the one-inch object-glass can be measured to the $\frac{1}{1000}$ of an inch. Should, therefore, one of the $\frac{1}{1000}$ of the eye-piece micrometer be divided into four parts, then every one of these divisions would be the $\frac{1}{4000}$. Again, if with another power it was found that $\frac{1}{1000}$ of an inch on the stage micrometer coincided with ten of the spaces on the eye-piece micrometer, then the value of each of the eye-piece micrometer divisions would be the $\frac{1}{10000}$ of an inch. It will be found in practice, when high numbers are being observed, that the stage movements are rather too coarse to bring the lines in the two micrometers accurately over each other; the small screw at the end of the brass, as shown in fig. 125, must then be employed. We have hitherto spoken only of the numbers in the eye-piece micrometer coming out even, but such is rarely the case; the chances are, that there will be a very minute variation between any two or more of both sets of lines. If it be not a matter of much moment to determine the value of the divisions accurately, and if no two lines coincide, the mean of a number of observations may be taken as an approximation to the truth; but by far the most desirable way to remedy the evil is to employ the draw-tube, before described at page 69; this, which must be graduated on one side, as shown in fig. 42, into inches and tenths, having been pulled out or pushed in, will be certain of making some of the lines in each micrometer agree.

The value of the divisions in the eye-piece micrometer should be found with all the object-glasses, and be put down in a tabular form, as follows; and, if the instrument be provided with a draw-tube, the table should include the extent to which it ought to be drawn out,

in order to make the value of the micrometer divisions even numbers:—

Object-glass.	Draw-tube.	Value of small divisions in parts of an inch.
1 inch.	$1 \frac{4}{10}$ inch.	1,000 of an inch.
$\frac{1}{2}$ ”	close.	2,500 ”
$\frac{1}{4}$ ”	$1 \frac{1}{10}$ inch.	5,000 ”
$\frac{1}{8}$ ”	$\frac{3}{10}$ ”	10,000 ”

It should be borne in mind that, when it is required to ascertain the value of the divisions in the eye-piece micrometer with the highest powers, the division into hundreds will occupy too much of the field of view, some smaller parts of an inch, such as the two-hundredth or five-hundredth, should then be used, and the number of the divisions corresponding to that quantity be multiplied by two hundred or five hundred, as the case may be.

To find the Value of the Divisions in the Positive Eye-piece Micrometer.—This instrument, before described at page 192, is used in the same manner as the above-mentioned. Mr. Ross, who always adopts this form in preference to the negative, does not employ the draw-tube with his microscopes. The micrometers, as shown in fig. 124, are ruled in squares, and one or more of them, of different degrees of minuteness in their ruling, may be employed; but it has been found in practice that divisions ruled about $\frac{1}{100}$ of an inch apart will suit nearly all the powers. The method of finding the value of the divisions, with each of the object-glasses, is performed by means of a stage micrometer, in the manner previously described. The positive eye-piece gives a much better view of the micrometer than the negative one; but the definition of an object to be measured is not quite so good. Mr. Ross generally rules his micrometers in squares; but Mr. Jackson prefers lines, on

account of the greater facility afforded for counting. As with the negative eye-piece micrometer, so with this, it becomes necessary to put down in a tabular form the value of each of the sides of the squares, with the different objects. The plan adopted by Mr. Ross is here shown. The upper line indicating the value of the divisions in fractions of an inch, the lower line the same value in a decimal notation.

	2-in.	1-in.	$\frac{1}{2}$ -in.	$\frac{1}{3}$ -in.	$\frac{1}{4}$ -in.
Value of each space in the Micrometer Eye Glass, with the various Object Glasses.	$\frac{1}{400}$	$\frac{1}{970}$	$\frac{1}{1900}$	$\frac{1}{4300}$	$\frac{1}{9000}$
	·0025	·001031	·000526	·0002325	·0001111

To find the Value of each Revolution of the Screw, or parts of a Revolution of the same, in the Cobweb Micrometer.—When about to be used, the cylindrical portion containing the eye and field lens is to be placed in the end of the compound body, in the same manner as an ordinary eye-piece, and a micrometer divided into hundreds and thousands, as employed with the other instruments, being placed on the stage, and its lines brought into the focus of the object-glass. The graduated head of the micrometer being set at zero, and the cobwebs exactly coinciding with each other, the milled head is now to be turned, and notice taken, how many revolutions, or parts of a revolution, are made before the cobwebs are opened sufficiently wide, so as to cover a certain number of the divisions of the image of the stage micrometer. It having been previously stated, that the screw employed to separate the cobwebs is provided with a hundred threads in an inch, and that the graduated circle in connexion with it is divided into a hundred parts, should it, therefore, be found that five revolutions of the screw cause the cobwebs to open, so as to cover ten divisions in that part of the stage micrometer divided into

thousands, it follows that one revolution of the screw would be equal to the $\frac{1}{500}$ of an inch, and one division of the graduated head would be $\frac{1}{100}$ of $\frac{1}{500}$, or $\frac{1}{50,000}$ of an inch. The comb at the bottom of the field of view, as shown by fig. 129, will indicate the number of the revolutions, as the teeth commence from the fixed cobweb. In those microscopes provided with a draw-tube, the divisions may always be brought out even numbers; but such will not be the case with all the object-glasses in a microscope not so provided, and the determination of the value of each revolution will then become a rather more complicated matter, as will presently be shown. The value of each revolution of the screw, with the different object-glasses, should be set down in a tabular form, as was shown in the case of the eye-piece micrometers.

Directions for the Use of the Eye-piece Micrometer.—If there be a draw-tube to the compound body, it should be adjusted according to the table shown at page 200, the object having been brought into the centre of the field, and the micrometer properly adjusted, so that the horizontal line be in the direction of the diameter to be measured. Read the measurement in the small divisions, and suppose that, with the half-inch object-glass, an object occupies seventeen of these; and it having been shown by the table at page 200, that the value of each division of the eye-piece micrometer, with the half-inch object-glass, was the $\frac{1}{2500}$ of an inch, this number must, therefore, be divided by seventeen, and the result will be the $\frac{1}{425}$ of an inch, or the diameter required to be found; or, should it be preferred to set down the diameter in decimals, then, by adding ciphers to the seventeen, and making it the dividend, and 2,500 the divisor, it may be shown that the diameter is .0068. The positive eye-piece micrometer supplied by Mr. Ross is used precisely in the same way as the above-mentioned instrument; but, there being no draw-tube, the value of the numbers of the glass micrometer cannot be altered in any way from those mentioned in the table; the squares must be counted as the straight lines are in Mr. Jackson's form, and the dimensions of any object ascertained precisely in the same manner as

before described,—viz., by dividing the value of each square, as given in the table, by the number of squares occupied by the object; or, if the decimal notation be preferred, by adding ciphers to the number of the squares, and dividing it by the value of one square, and the quotient will be the dimensions required.

To Use the Cobweb Micrometer.—Before an object is measured, it must be brought to the middle of the field; and, after the table has been consulted, which shows the value of each revolution of the screw, and of each division of the wheel affixed to it, the cobwebs must be examined, in order to see whether they both accurately coincide when the zero point of the graduated wheel is opposite the index. The screw being now turned, until the image of the object is, as it were, enclosed between the cobwebs, the number of turns and parts of a turn are both shown by the indices; the former by the comb at the lower part of the field of view, the latter by the division opposite to which the index points. It must, however, be borne in mind, that both with this micrometer and with those of the eye-piece form, several measurements of the same object ought to be made; and if there should be any difference between them, the mean of the two extremes should be taken as the correct one. The measurements made with the cobweb micrometer are said to exceed those of all the other forms of instruments; and that, with an object-glass of one-eighth of an inch focus, even a quantity as small as the eight-hundred-thousandth of an inch can be appreciated. This is, at least, ten times as delicate as is required; for Mr. Ross, in his experiments, preliminary to the constructing of his beautiful dividing-engine, found that, with the highest magnifying powers, it was impossible to ascertain the position of a line nearer than to the eighty-thousandth of an inch.

Measurements of an Object made by means of a Stage Micrometer and a Camera Lucida.—For this very valuable plan, we are indebted to Mr. Lister. By means of the camera lucida, a sketch of the object is first made; the microscope being fixed in the horizontal position, the object is then removed,

and a stage micrometer placed in the focus of the object-glass instead; a sketch of its divisions is also to be made on the same paper as the object itself was sketched on, and all the optical arrangements of the microscope unaltered. The object, therefore, and the micrometer being both magnified to the same extent, their images will consequently bear the same relation to each other as the bodies themselves. The method of effecting this operation is exhibited by the following figure:—In fig. 130 is shown how the rays of light coming from the eye-piece, or from any distant object, are reflected by the prism, in such a manner as to enter the eye, at right angles to their original direction; and as the image of an object is always referred by the eye to a situation in the same direction as that from which the rays entering the eye proceed, the magnified image of the object will be seen on a paper laid on a table beneath the camera, and can there be readily sketched. Supposing, in the present case, that the objects under examination be granules of starch, or even

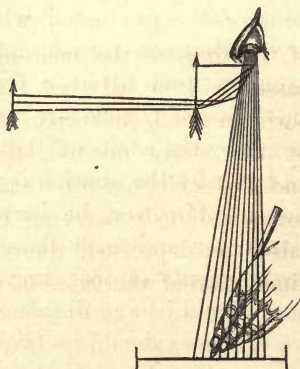

Fig. 130.

blood discs, these can easily be sketched in outline; when, therefore, the micrometer is substituted for the starch, its divisions or squares can be drawn over the starch granules, as shown by figs. 131 and 132, the former being squares of $\frac{1}{300}$ of an inch, the latter $\frac{1}{1000}$; and, as the value of the squares, or divisions of the micrometer, is known, the objects over which the lines are drawn can also be readily ascertained by the application of a pair of compasses; and, if necessary, the squares, as shown in figs. 131 and 132, can be further subdivided into four, so that the diameter of an object can be measured even to the fourth part of the quantity given by the lines on the micrometer. The whole field of view need not be covered with lines, as shown by the figures; but a

single square, or even the exact distance of any two or more

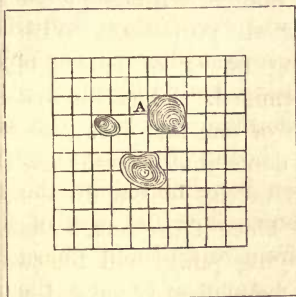

Fig. 131.

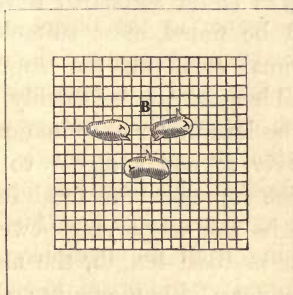

Fig. 132.

of the lines of the micrometer, together with a pair of compasses, will be all that is required. It must, however, be borne in mind, that when the size of an object is ascertained by the above method, the distance between the camera and the table must be always the same; if the end of the compound body carrying the camera were ever so slightly raised or depressed, there would be either an increase or diminution of the value of the squares of the micrometer.

CHAPTER IV.

ON THE METHODS OF OBTAINING THE MAGNIFYING POWER OF SINGLE AND COMPOUND MICROSCOPES.

THE method of estimating the magnifying power, either of simple or compound lenses, is to compare an object of known size, such as a micrometer, seen through them with the nearest distance that another object, also of known size, can be distinctly seen; this latter distance is termed the standard of distinct vision, and with it all the magnifying powers must be compared. All opticians of the present day adopt ten inches as a standard. Sir David Brewster adopts five inches,

in the old optical works, eight inches was generally employed as the standard; but, the number ten being a decimal, will be found most suitable for all purposes. With this decimal standard, the magnifying power of lenses, of any focal length, can be readily determined. Thus, for instance, if the lens under examination be of one inch focus, we have merely to add a cipher to the denominator of the fraction, which expresses the focal length of the lens, and the result will be the magnifying power. Thus, if the lens be half an inch in focal length, the magnifying power will be twenty diameters; if one quarter, then forty diameters; and if one inch, then ten diameters, and so on. When, however, the focal length of a lens is very small, it becomes a difficult task to measure accurately its distance of focus. In such cases, says Mr. Ross,* “the best plan to obtain the focal length for parallel, or nearly parallel, rays, is to view the image of some distant object, formed by the lens in question, through another lens of one inch solar focal length, keeping both eyes open, and comparing the image presented through the two lenses with that of the naked eye. The proportion between the two images so seen will be the focal length required. Thus, if the image seen by the naked eye is ten times as large as that shown by the lenses, the focal length of the lens in question is one-tenth of an inch. The panes of glass in a window, or courses of bricks in a wall, are convenient objects for this purpose. In which ever way the focal length of the lens is ascertained, the rules given for deducing its magnifying power are not rigorously correct, though they are sufficiently so for all practical purposes, particularly as the whole rests on an assumption, in regard to the focal length of the eye, and as it does not in any way affect the actual measurement of the object.”

In the preceding account, we have estimated the magnifying power in diameters, or according to the measure termed *linear*; but as every object is magnified in breadth as well as in length, it follows that, if it were drawn as broad as it is long, a very different idea of its measure would result:—

* Article “Microscope,” *Penny Cyclopædia*.

thus, suppose a , in fig. 133, to represent an object of its natural size, and that it be required to represent the same when magnified four times in length and four times in breadth, the square $b c d e$ will give such view; and if this be compared with the original object a , it will be seen that there are sixteen such squares contained in it. This measurement, which is rarely used, except to astonish the public, is called the *superficial* magnifying power, and is always

found by squaring the linear, or, in other words, by multiplying the linear by itself. The magnifying power of single lenses, like the value of the divisions in the different kinds of micrometer, may be set down in a tabular form, thus:—

Focal lengths in inches.	Linear Magnifying Power.	Superficial Magnifying Power.
2	5	25
$1\frac{1}{2}$	6.6	43.5
1	10	100
$\frac{3}{4}$	13.3	176.8
$\frac{1}{2}$	20	400
$\frac{1}{4}$	40	1600
$\frac{1}{8}$	80	6400
$\frac{1}{10}$	100	10000

To ascertain the magnifying power of the compound microscope, the method employed is the same as that proposed by Hooke, in his *Micrographia*, as long ago as 1667, and before described at page 4, it is thus accomplished:—Place on the stage of the microscope a micrometer either of glass, ivory, or mother-of-pearl, divided to some fraction of an inch ($\frac{1}{10}$ will answer the purpose for all the lower powers), and, at ten inches distant from the eye, hold a rule, divided into tenths of an inch, in a line parallel with the micrometer; a magnifier and eye-

piece being adapted to the compound body, the lines on the stage micrometer are to be brought into focus; if now the eye not employed in looking through the eye-piece be cast, as it were, down on the rule, the micrometer divisions, and those on the rule, will be seen at one and the same time; and, after a little practice, it will be found a very easy matter to count how many divisions of the rule are covered by two or more of the micrometer. Thus, for example, suppose that each division of $\frac{1}{100}$ of an inch occupies just one inch of the rule, the magnifying power will then be one hundred times, as $\frac{1}{100}$ of an inch is made as large as one inch; if the same divisions, either with another object-glass or eye-piece, correspond to one-and-a-half inch of the rule, then the power will be one hundred and fifty diameters; should, however, the divisions of the micrometer not correspond with even divisions on the rule, the magnifying power will not come out a whole number, and we must then set it down as such, or, if a draw-tube is present, then the number can easily be made even; thus, suppose that the $\frac{1}{100}$ of an inch of the micrometer coincides with nine-tenths-and-a-half of the rule, the magnifying power then will be ninety-five diameters; if nine-tenths and three-quarters of a tenth, then the power will be in fractions $97\frac{1}{2}$, or in decimals 97.5. The magnifying powers of the different object-glasses, with each of the eye-pieces, should, also, for convenience of reference, be set down in a tabular form. Mr. Ross supplies with his microscopes a table of the following construction, but having appended to

Magnifying Power of the Object-glasses with the various Eye-glasses.						
Eye-glasses.	OBJECT-GLASSES.					
	2 In.	1 In.	$\frac{1}{2}$ In.	$\frac{1}{4}$ In.	$\frac{1}{8}$ In.	$\frac{1}{16}$ In.
A	20	60	100	220	420	600
B	30	80	130	350	670	870
C	40	100	180	500	900	1400

it, that described at page 201, with the value of the divisions of the eye-piece micrometer with each of the object-glasses. For the use of those who have draw-tubes applied to their microscopes, another column might be added to denote the distances it must be drawn out, in order that the value of the micrometer divisions and the magnifying power may be set down in even numbers.

Several other methods, besides those now described, have been from time to time adopted to ascertain the magnifying power of the compound microscope; but as none are so accurate as that of Hooke, it has been thought unnecessary to describe them. The value of the divisions in the micrometer scale and the magnifying powers of the different object-glasses are, in most cases, supplied by the maker of the instrument—they should be always so; but for those who are anxious to work the subjects out for themselves, it is hoped that the preceding methods will not be deemed out of place.

The late Mr. Coventry and Sir John Barton were celebrated for ruling micrometers of extreme delicacy, some of these, still extant, have as many as ten thousand lines in an inch; Mr. George Jackson, a gentleman whose name has been so frequently mentioned in connection with the improvements in the mechanical arrangements of the microscope, has also paid considerable attention to this subject, and has succeeded in ruling ten thousand lines in an inch, and in crossing these at right angles with others precisely the same distance apart, so that a series of squares are formed, each having a superficial area of the one hundred millionth of an inch. These are very remarkable as specimens of skill, but are far too minute for all practical purposes.

In England, microscopists are in the habit of setting down the measurements made by micrometers either in inches, or in fractional or decimal parts of an inch; but in France, and some other parts of the continent, either a line or millimetre, and fractional divisions of the same, are employed for a like purpose. For the convenience of those who may wish to compare foreign measures of length with our own, the following tables have been drawn up, together with directions for

converting either English inches, or parts of an inch, into lines or millimetres, or these last into English measures.

Parts of an English Inch.

A Paris line	=	.088815	or	$\frac{8}{90}$	of an English inch.
A metre	=	39.37100	inches	English,	or 3.281 feet.
A centimetre	=	.39371	,,	or a little more than	$\frac{1}{30}$ of an inch.
A millimetre	=	.039371	,,	or a little more than	$\frac{1}{300}$ of an inch.

To convert Paris Lines into English Measure.

Multiply the numerator of the fraction $\frac{8}{90}$ by the number of Paris lines stated, or divide the denominator of the fraction by the same number, or multiply the number .088815 by the number of lines and parts of the same.

To convert Millimetres into English Measure.

Multiply the number .039371 by the number of millimetres and parts of the same, the quotient will be the equivalent measure in decimal parts of the English inch.

The line is often made use of in scientific works in this country; but as no two persons are agreed as to whether its value is the one-tenth or one-twelfth of an inch, it follows that, in all measures in which it is employed, the value attached to it should be stated; if the Paris line is the one adopted, neither the one-tenth or one-twelfth of an inch is its correct value, although the latter number comes nearest the truth.

CHAPTER V.

CAMERA LUCIDA.

THE camera lucida, before described at page 128, was invented by Wollaston in 1807. It consists of a four-sided prism of glass, as represented in section, by fig. 134, the sides and angles being similar to those shown by A B C D. The rays of light proceeding from an object M N, after being

reflected by the faces DC ; CB to the eye E will be

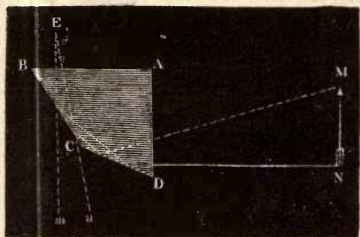

Fig. 134.

referred by an observer to $m n$, and an image of the object will be there seen, if a piece of white paper be placed for the rays to be projected on. The prism is generally set in a frame of brass, in the manner exhibited by fig. 88, all parts of it being covered over except the

side next the eye-piece and a small portion of the edge to which the eye is to be applied; the frame is capable of being adapted to either of the eye-pieces by a short tube. The prism itself has two slight adjustments, one to bring its upper face horizontal, and the other to make the image of the object fall flat on the paper on which it is to be drawn. A lens is generally placed under the camera, in order that the rays of light from the pencil employed in sketching and the object itself may be seen under the same angle. Several contrivances have been had recourse to, in order to simplify certain difficulties that arise in the use of this instrument; one of these plans is shewn in section by fig. 135, and consists of a mirror M ,

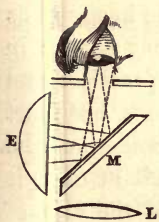

Fig. 135.

composed of a thin piece of dark coloured glass cemented to a piece of plate glass, inclined at an angle of 45° , in front of the first lens of the eye-piece E . The light escaping from the object, through the lens E , is assisted in its reflection upwards to the eye by the dark glass; and this, says Mr. Ross,* “effects a further useful purpose of rendering the paper less brilliant; and thus enabling the eye better to see the reflected

image.” If required, a double convex lens L may be placed beneath the mirror, as in the case of the prism. The polished steel disc, the invention of Sæmmering, before

* Article “Microscope.”

described at page 129, may be employed as a substitute for the camera, over which it is said to have some few advantages.

Method of using the Camera Lucida with the Microscope.—The first step to be taken after the object about to be drawn has been properly illuminated, adjusted, and brought into the centre of the field of view, is to place the compound body of the microscope in a horizontal position, and to fix it there. The cap of the eye-piece having been removed, the camera is to be slid on in its stead; if the prism is properly adjusted, a circle of white light, with the object within it, will be seen on a piece of white paper placed on the table immediately under the camera, when the eye of the observer is placed over the uncovered edge of the prism, and its axis directed towards the paper on the table. Should, however, the field of view be only in part illuminated, the prism must either be turned round on the eye-piece, or be revolved on its axis, by the screws affixed to its frame work, until the entire field is illuminated. The next step is to procure a hard, sharp-pointed pencil, which, in order to be well seen, may be blackened with ink round the point, the observer is then to bring his eye so near the edge of the prism that he may be able to see on the paper, at one and the same time, the pencil point and the image of the object; when he has accomplished this, the pencil may be moved along the outline of the image so as to trace it on the paper; however easy this may appear in description, it will be found very difficult in practice, and the observer must not be foiled in his first attempts, but must persevere until he accomplishes his purpose. Sometimes he will find that he can see the pencil point, and all at once it disappears; this happens from the movement of the axis of the eye; the plan then is to keep the pencil upon the paper, and to move about the eye until the pencil is again seen, when the eye is to be kept steadfastly fixed in the same position until the entire outline is traced. It will be found the best plan for the beginner to employ, at first, an inch object-glass, and some object, such as a piece of moss, that

has a well defined outline, and to make many tracings, and examine how nearly they agree with each other, and, when he has succeeded to his liking, he may then take a more complicated subject. If the operation is conducted by lamp-light, it will be found very advantageous not to illuminate the object too much, but rather to illuminate the paper on which the sketch is to be made, either by means of the lamp with the condensing lens, or a small taper placed near it. When the object is so complicated that too much time would be required for it to be completed at one sitting, the paper should be fixed to the table by a weight or on a board by drawing-pins. An excellent plan to adopt is to fix the microscope on a piece of deal about two feet in length and one foot in breadth, and to pin the paper to the same, there will then be no risk of the shifting of the paper, as when the wood is moved, both microscope and paper will move with it.

In all sketches made by the camera, certain things must be borne in mind; the eye, when once applied to it, should be kept steadily fixed in one position, and if the sketches are to be reserved for comparison with others, the distance between the paper and the camera should be always the same. A short rule or a piece of wood may be placed between the paper and the under surface either of the compound body or the arm supporting it, in order to regulate the distance, as the size of the drawing made by the camera will depend upon the distance between it and the paper. It is also very desirable, before the camera is removed, to make a tracing in some part of the paper of two or more of the divisions of the stage micrometer, in order that they may form a guide to the measurement of all parts of the object. Some persons cover the whole of the drawing over with squares, to facilitate not only the measurement, but in order that a larger or smaller drawing may be made from it than that given by the camera. It must be recollected that an accurate outline is the only thing the camera will give, the finishing of the picture will depend entirely upon the skill of the artist himself.

Uses to which the Camera Lucida may be applied.—Besides

the valuable assistance rendered to the draughtsman by this instrument, its application to micrometry is also of no small utility; the method before described at page 203 will answer for all purposes. If it be required to make a very large but accurate diagram of any microscopic object, a true outline of it may be drawn by following these directions. A large sheet of paper, attached by pins to a drawing-board, having been laid on the floor, and the microscope placed horizontally, with its compound body projecting as far over the table as possible, and the object and camera having been properly adjusted,

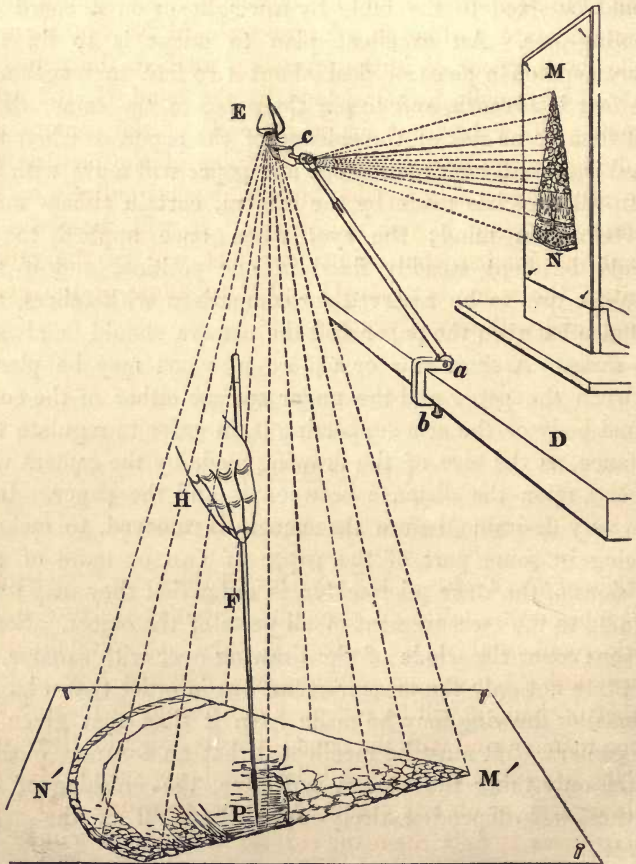

Fig. 136.

a pencil fastened into a long piece of light but hollow cane must then be provided, and the artist, either standing or sitting, and looking down through the camera, will see the image on the paper, and after a little practice will be able to trace its outline as easily as when the paper was placed on the table only a few inches below it. Another way of effecting the same end is shown in fig. 136, which is that of placing the tracing $M N$ made from the microscope by the camera as an object for another camera C , of the kind employed by artists for making sketches of landscapes, this being fastened to the table D by the screw b , and the object $M N$ set up in front of it, an accurate outline on a larger scale $M' N'$ can then be made on the floor, as in the preceding method; the pencil P , with a long handle F , being held by the hand H , the artist standing either in front or on one side of the camera, and applying his eye to it as at E . The size of the picture will, like all others made by the camera, depend entirely on the distance between it and the paper. It will, however, be found in practice, that about four feet will be the utmost limit of the space between C and P to allow of the pencil being used with any advantage.

CHAPTER VI.

ON THE POLARIZATION OF LIGHT.

Origin of the Term.—"If," says Sir D. Brewster,* "we transmit a beam of sun's light through a circular aperture into a dark room, and if we reflect it from any crystallized or uncrystallized body, or transmit it through a thin plate of either of them, it will be reflected and transmitted in the very same manner, and with the same intensity, whether the surface of the body is held above or below the beam, or on the right side or left, or on any other side of it, provided that in all these cases it falls upon the surface in the same manner, or,

* *Treatise on Optics*, page 157.

what amounts to the same thing, the beam of solar light has the same properties on all its sides, and this is true of light emitted from candles or any luminous bodies, and all such light is called *common light*." But if the same light be allowed either to fall upon a rhomb of Iceland spar, or upon a plate of glass at the angle of incidence of 56° , as was first discovered by Malus in 1808, it will become separated into two rays or beams, each having different properties on different sides; that is, in the case of the glass, supposing we hold another plate of glass over the first, it will be found that the reflected ray will pass through it when held in some positions and not in others; if the glass be turned round a quarter of a circle without altering its angle to the horizon, the light will be reflected in one quarter, transmitted in a second quarter, reflected again in the third, and so on until the circle is completed, when it will be again transmitted; that is, a beam of light has acquired the property of sides, on two of which it can, and two of which it cannot, be reflected; and as these properties bear some analogy to the poles of a magnet, a ray of light so modified is said to be *polarized*. In the case of the Iceland spar, the polarization is effected by refraction, but in the glass by reflection. In order to explain the polarization by reflection from glass, the apparatus represented by fig. 137 has been contrived; it consists of two tubes of wood

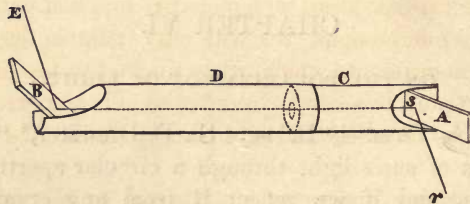

Fig. 137.

D C, having at one end a plate of glass A capable of being turned round an axis, so that it may form different angles with the axis of the tube; another tube, C a little smaller than D, carrying a similar piece of glass B, is made to fit into it, so that by turning either of the tubes, the two plates may be placed in any position in relation to one another.

If a beam of light rs be allowed to fall upon A at the polarizing angle of 56° , it will be reflected through the tubes and will fall upon the second plate B; if this plate be also placed at the angle of 56° , and the tube to which it is attached be turned round, so that when it occupies the position represented by the figure, the ray rs will be reflected to E; if the tube be again turned slowly round, the light will be found to pass through the plate, when it has arrived at a distance of 90° from the starting point; if the tube be turned again, the light will get more and more faint until another 90° are arrived at, when the ray will undergo total reflection, and so will the changes take place every quadrant until the starting point is again reached, the ray rs being alternately reflected and transmitted. For the purpose of polarizing light, various substances have, from time to time, been employed; amongst the most useful for the microscope will be found either glass, blackened on one side, or a bundle of thin glass plates, a crystal of Iceland spar, or a crystalline mineral termed tourmaline. It would be foreign to our purpose here to enter into any of the numerous theories that have been broached, to account for the above described phenomena, for these the reader is referred to the works that are specially devoted to the subject; but as one of the principal objects of this treatise is to teach those who are uninitiated in microscopic science, the use of the various kinds of apparatus supplied with the best achromatic microscopes, we will only take notice of those polarizing instruments which, when applied to the microscope, have been found necessary, in order to aid the observer in his investigations into the structure of organic and inorganic substances.

The polarizing apparatus most useful to the microscopist has been already described at page 104; it consists, as shown in figs. 56 and 57, of two prisms of calcareous spar, constructed after the plan of the late Mr. Nicol, of Edinburgh, who employed for the purpose a rhomb of the spar divided into two equal portions, in a plane passing through the acute lateral angles, and nearly touching the obtuse solid angles. The cut surfaces having been carefully polished were then

cemented together with Canada balsam, so as to form a rhomb of nearly the same size and shape as it was before the cutting; by this arrangement the two rays into which a beam of ordinary light passing through a rhomb of this spar would be separated, only one is transmitted, the other being rendered too divergent, hence it has received the name of the *single image prism*. Two of these must be provided, one to be adapted to the under surface of the stage, and termed the *polarizer*, as shown by fig. 55, whilst the other, called the *analyzer*, is placed above the eye-glass. To effect the same purpose, but not in so good a manner, some persons employ a bundle of glass plates as a polarizer, and a tourmaline as an analyzer; but the colour of the latter is often objectionable in the compound microscope, where everything that will diminish the brightness of the light and brilliancy of the colours should be avoided. It will be found that a tourmaline of a neutral tint forms an excellent analyzer, having one great advantage, viz., that when placed over the eye-piece, the field of view is not contracted as it is when a Nicol's prism is employed. "The best tourmaline to choose," says Mr. Woodward,* "is the one that stops the most light when its axis is at right angles to that of the polarizer, and yet admits the most when in the same plane."

In order to illustrate some of the most striking phenomena in polarized light in a very simple way, by the achromatic compound microscope, the apparatus consisting of two prisms and a film of selenite, as described at page 104, will be nearly all that will be required for the purpose, as well as for the examination of minute animal, vegetable, and mineral structures; we will, therefore, proceed at once to the application of the same.

Method of using the Polarizing Apparatus.—The polarizing prism represented by figs. 55, 56, and 57, having been adapted to the under surface of the stage, either another prism or a plate of tourmaline is to be placed over the eye-piece, or in the end of the draw-tube, as shown by fig. 64, and the light having been reflected through them by the mirror, the step

* *Familiar Introduction to the Study of Polarized Light*, page 31.

that next becomes necessary is to make the axes of the two prisms coincide; this is done by revolving either the upper or lower one, and noticing whether, in some positions, the light is completely cut off, and in others wholly transmitted; if the field of view is not entirely darkened twice during one revolution of the prism, the axes do not correspond; to remedy this, the compound body (if capable of being turned away from the stage, as in Mr. Ross and Mr. Powell's instruments,) must be shifted either to the right or the left, until this point is attained. If now a thin plate of selenite, or other doubly refracting crystal, be placed on the stage, and be brought into the focus of the object-glass, it will cause the light to pass through the prisms, and the selenite, according to its thickness, will present either a red or a green colour; if one of the prisms be now revolved slowly, we shall find that more and more light will be transmitted, but the intensity of the colours will be lost, and when a quarter of a revolution has been accomplished, the brilliancy of the colours will re-appear; but what was originally red will become green, and the green red. If the selenite be removed, and some very thin crystals of sulphate of copper, tartaric acid, or one of the other substances presently to be enumerated, be substituted for it, a most gorgeous set of colours will be seen; and as the prism is being revolved, the same alternations of reds and greens will take place as with the selenite. If, however, a piece of glass, with some perfect crystals of iodide of potassium or common salt upon it, be placed under the same conditions, neither the light or the colours will be seen; hence bodies may be divided into those that polarize and those that do not polarize: to the latter class belong the iodide of potassium and common salt just named. The primitive form of crystal of these substances is the cube, and it has been found, by experiment, that no perfect crystal of this system ever exhibits colour when placed between the prisms, and a pencil of light incident upon them is refracted always into a single pencil on its emergence; but by far the greater number of other crystalline bodies will divide the pencil into two, or, in other words, will doubly refract it; one of these last must, therefore, be chosen

to exhibit colours; but it happens that there is one part or axis of the crystal in which the property of double refraction does not exist, this is called the axis of [no] double refraction. In other crystals there are two such axes, and in some bodies there are certain planes along which, if the refracted ray passes, it experiences no double refraction: this is termed the neutral axis, and no colour will be produced around it when polarized light passes through the crystal in the direction of this axis; but whenever polarized light passes through the crystal, in the direction of the axis of double refraction, a series of beautifully coloured rings will be seen. In large crystals, such as rhombs of Iceland spar, certain angles must be ground down to a plane surface and be polished, in order to exhibit the rings; when this is accomplished, there will be found in some positions of the analyzing prism a black cross, with a series of rings around it, and in others a white cross, with the colours of the rings reversed. In those crystals having two axes of double refraction, a double system of rings will be seen. Nitre is a beautiful instance of this kind, and a transverse section of a prism of this substance, when ground down and polished, will, with polarized light, exhibit the double system of rings; but if the prism be ground in some other directions, colour will be produced; hence it becomes necessary, in order to exhibit the phenomena of colour, to have crystals cut either in the direction of the axis of double refraction, or in a plane inclined at certain angles to it. But when the same substances, in the state of solution, are crystalized on glass, it frequently happens that many of the crystals will be arranged with their axes of double refraction in the direction of the beam of polarized light; all such, therefore, will exhibit colours, as will those also in which the thickness of the crystal is not below a certain standard, this for selenite is the .00046 of an inch, the red colour is always produced by the thickest films, the violet by the thinnest. It must, however, be borne in mind that the red and green are always complementary to each other, or together make white light.

Some persons, at the suggestion of Sir David Brewster, employ a rhomb of Iceland spar for an analyzer, instead of a

Nicol's prism; this should be so thick (when the selenite is placed on the stage) as to separate the red beam from the green by double refraction; and in order to protect the rhomb from scratches, a plate of thin glass should be cemented to two of its surfaces; with this prism as an analyzer, and with one of Nicol's as a polarizer, a film of selenite of uniform thickness, and with a brass plate, three inches by one, perforated with a series of small holes, from the one-sixteenth to the one-fourth of an inch in diameter, a variety of interesting phenomena may be exhibited, as described by Mr. M. S. Legg, in the *Transactions of the Microscopical Society*.* If the brass plate be placed on the stage, with the smallest hole in the field of view, and an inch object-glass be employed as the magnifier, the rhomb, when placed over the eye-piece, will give two images of the aperture,

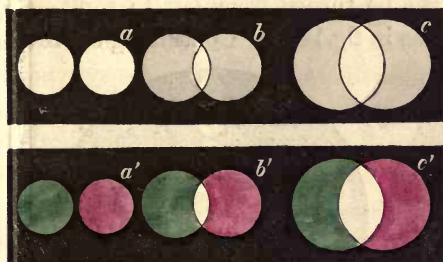

Fig. 138.

as in fig. 138, *a*. If the eye-piece be now turned, the images will describe a circle; if a larger aperture is brought into the field of view, the images will overlap, as shown in fig. 138, *b* and *c*.

If the Nicol's prism be now adapted to the under surface of the stage and the eye-piece revolved, it will be found that in certain parts of the revolution there will be two images, whilst in others there will be only one fig. 139, *abcd*. If now the film of selenite be placed underneath the brass plate, the apertures will be coloured red and green, fig. 138, *a'b'c'*, and if the eye-piece be revolved, at every quarter of the circle the colours will be seen to change alternately from red to green, and from green to red, fig. 139, *a'b'c'd'*. If the brass be again slid along so as to bring the two largest apertures into focus, the images will overlap, and where they overlap white light will be produced, as shown in fig. 138, *b'c'*. The experiments may be varied by

* Vol. II., Part II.

employing two double refracting crystals, placed one over the other, and by removing the Nicol's prism, but retaining the brass plate on the stage; two distinct images will then be

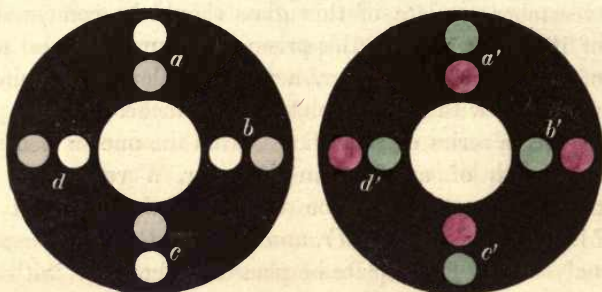

Fig. 139.

seen, but at twice the original distance from each other. If the crystal nearest the eye be turned from left to right, two faint images will appear, as in fig. 140, *a*. Continuing the revo-

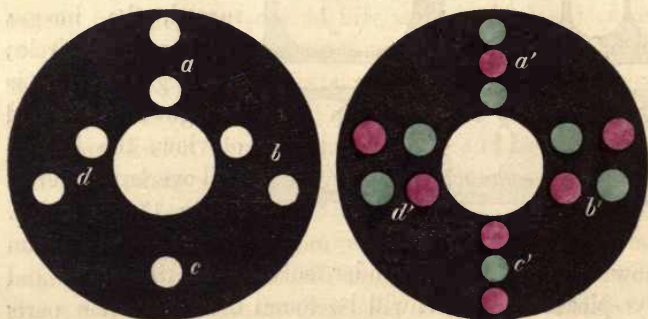

Fig. 140.

lution, four images will be equally luminous, and when the crystal has turned round 90° , there will be only two images of equal brightness; continuing the turn, two other faint images will appear; further on, four images of equal brightness, and at 180° they will all coalesce into one bright image *c*.

If a film of selenite be placed between the two crystals, we shall see three coloured images instead of two colourless ones, fig. 140, *a'*; of the three, the two outer may be green, the middle red. By turning the crystal nearest the eye, the middle image will gradually divide until the completion of the quarter of a

revolution, when four images will appear, as at b' , two being red, the other two green; revolve the crystal another quarter of a circle, the three images, as at c' , will re-appear, but with different properties—the two outer being now red, and the middle green; at another quarter four images will be seen, also with their colours reversed, as at d' , and at the completion of the circle, the original appearance will again occur.

These experiments of Mr. Legg are the same in principle as those first exhibited on a screen by Mr. Woodward, by the gas polariscope, the crystal having been placed within the focus of a lens of low power, and a tourmaline being used as an analyzer. Mr. Legg has successfully effected the same results by the achromatic compound microscope, and in order to afford an additional means of investigating these phenomena, he recommends the use of the erector, before described at page 110, by which the microscope is converted into a telescope of low power. When the Nicol's prism is used as a polarizer, the field of view will be too much limited for the action of the erector; in these cases it will be advisable to employ a bundle of thin glass plates, placed in such a manner that light may fall on them at an angle of $56^{\circ} 45''$, when the light reflected will be polarized, and a large field illuminated, but not with so much brilliancy as by the prism and concave mirror.

The usual mode of exhibiting microscopic objects by polarized light is to place them on the stage of the instrument with a Nicol's prism as a polarizer, adapted below the stage, and a similar prism above the eye-piece; in this way most crystalline bodies may be shown. Some few vegetable structures may also be exhibited in the same manner, amongst the latter may be enumerated the hairs on the leaf of the *Elcæagnus*, the siliceous cuticle of the *Equisetum*, and of some of the grasses, together with starch of various kinds, all of which are beautiful objects for the polarizing microscope. Many animal structures, such as feathers, slices of quill, horn, hoof, and other cuticular appendages, are best shown by placing a thin film of selenite or mica beneath them, by which they become intensely coloured; the selenite or mica should be of

unequal thickness, for, according to the different degrees of thickness, so will its colours vary. A list of those objects that will exhibit the most beautiful series of colours will be given in another part of the work. Mr. King, of Ipswich, has described, in the *Transactions of the Microscopical Society*,* a method whereby nearly all structures may be made to exhibit colour by polarized light; and as his account of the process cannot be well abridged, we will quote his own words. A Nicol's prism having been adapted to the under surface of the stage as a polarizer:—

“ Take for an analyzer a double image prism, of moderate separating power, and place it over the eye-piece of the instrument.

“ The field will then appear to be edged by two areas of less intensity than the centre, occasioned by the duplication of the circle of light.

“ Next put upon the stage a plate of selenite, which exhibits, under ordinary circumstances, the red ray in one position of the polarizing prism, and the green ray in another, and each arc will assume one of these complementary colours, whilst the centre of the field will remain perfectly colourless.

“ Into this field introduce any microscopic object; and, whatever its structure, it will exhibit the effects of polarized light with great intensity and purity of colour.

“ In this way many objects which, in the usual arrangement of the polariscope, undergo no change in colour, are made to display the most brilliant effects.

“ Sections of wood, feathers, *Algæ* and scales, are among the objects best adapted to this kind of exhibition.

“ By substituting selenite that shows a variety of colours, the effects are still more gorgeous.

“ The best power for the purpose, is a two-inch object-glass, the intensity of colour, as well as the separating power of the prism, being impaired under much higher amplification, although in some few instances, such as in viewing animalculæ, the inch object-glass is, perhaps, to be preferred.

“ This phenomenon,” he states, “ is attributable to the

* Vol. ii., Part ii.

double image prism separating the constituents of the polarized ray into two planes, and causing them to overlap each other, except at the edges where the light is analyzed; and whilst the combination of the complementary colours in the centre of the field produces again white light. Any object, therefore, placed in the white field, partakes of the characteristics of the selenite; one image being refracted into the plane which exhibits the green ray, assumes that colour, whilst the second image being refracted into the plane of the red ray, partakes of that tint. Should, however, the object be so large that actual separation of the images is not effected, the extremities and interstices only will be polarized, whilst the middle will remain dark, or present only its natural hue."

It may be here stated, that the film of selenite employed to give colour to objects, should be mounted between two glasses for protection; it may be even immersed in Canada balsam, in the same manner as an ordinary object. Some persons employ a large film mounted in this way between plates of glass, with a raised edge to act as a stage for supporting the object on, it is then termed the "*selenite stage*."

Cause of the Colours of Polarized Light.—In fig. 137 it was shown that when a beam of light reflected from a plate of glass, at the angle of $56^{\circ} 45'$, was received by another plate of glass at the same angle, it would be found (if this second plate were capable of being revolved) that in two positions in one revolution the light would be entirely stopped, whilst in two others it would be wholly reflected; in the microscope the same effect can be shown by two prisms, one either above the eye-piece or between it and the object-glass, and the other between the object-glass and the mirror. It has been stated before, that if a thin plate of a doubly refracting crystal were placed between the prisms (when in the situation that the transmitted ray of polarized light from the lowest prism was stopped by the upper prism), it would not only cause the light to pass through the first prism, but, according to the thickness of the plate of the crystal, so should we have either a green or a red colour, or some modification of the same, these colours being complementary of each other, or which,

together, would make white light. If a thick crystal were placed between the prisms, we should have no colour, but if a film of the same, we may have it either red or green; the reason of this is stated to be, that in the thick crystal the beam is split into two rays that are polarized in directions at right angles to each other; but in thin films of the same, the polarized rays are not at right angles to each other. From a very early period, philosophers have been employed in the investigation of the nature of light, and two principal theories have been advanced, one by Newton, who maintained that light is material, and is emitted by all self luminous bodies in minute particles; the other by Huyghens, who supposed that an elastic medium, called ether, fills all space, and occupies the intervals between the particles of all substances, and that luminous bodies excite vibrations in this ether, which spread by waves, in the same manner as those formed in water when a foreign substance, such as a stone, is dropped into it. This latter theory is the one now generally adopted, and has received the name of the *undulatory theory*. Light, as is well known, is made up of three colours, each colour being produced by a wave or undulation of a particular length; if all vibrate together, white light is formed, but if they are placed under other conditions, darkness or colour may result from the waves interfering with each other. If the difference of length between two waves be an even number of half undulations, the two will coincide and produce a colour equal in intensity to the two combined; but if the difference be an odd number, darkness will result. Let us now apply this principle to the selenite between the two prisms, and let us suppose the prisms to be arranged so that no light may be seen when the eye is applied to the eye-piece; the polarized beam, therefore, from the first prism not being able to pass through the analyzing prism, a plate of a double refracting crystal is introduced; this has the property of dividing the polarized beam into two coloured rays, which are polarized at right angles to each other; but at angles of 45° to the original ray, these falling on the analyzing prism, and being inclined somewhat nearer to its crystallographical axis than the polarized beam originally

was, some of its vibrations will pass through; but as these vibrations do not all arrive at the prism at the same time, colour is the result from slight interference in the undulations; and if, in the first case, the colour is red, then, as the prism is turned, the green will arrive at the same point of the crystallographical axis of the prism, and some of its undulations will also pass through and, by interference, produce a green colour. The red and green colours are, as has been before stated, complementary, or the one is what the other wants to form white light; if a double refracting crystal of Iceland spar be used instead of the Nicol's prism, it can be shown that where the red and green are super-imposed, white light results. But as this subject will be best understood by reference to a diagram, the author has selected the following from the valuable *Introduction to the Study of Polarized Light*, lately published by his friend, Mr. Woodward. In order to render the diagram more intelligible, it may be as well here to state that ordinary light is represented by a cross, which denotes that its vibrations are in planes, at right angles to each other, whereas, when one set of such vibrations only is shown, the light is said to be polarized. Mr. Woodward's description of the production of colour by polarized light being in itself so comprehensive, the author has been induced to copy it nearly verbatim.

Let A B C D, fig. 141, represent the rectangular vibrations

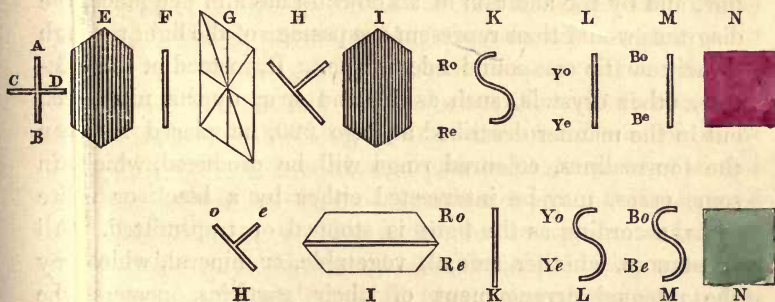

Fig. 141.

of common light; E a plate of tourmaline placed with its crystallographical axis in a vertical direction; this is called the polarizer; a F beam of polarized light obtained from A B C D

by the stoppage of plane CD; G a film of selenite of such a thickness as to produce red or green light; H the polarized beam F split into two planes at right angles to each other; I a second tourmaline or analyzer, with its axis in the same direction as that of E; by this all the vibrations of oe that are not inclined at a greater angle than 45° to the axis of the analyzer can be transmitted and again be brought together; K the waves $R^o R^e$ of red light, meeting in the same state of vibration, and forming a wave of red light of doubled intensity; LM the waves Y^o and Y^e and $B^o B^e$ for yellow and blue meeting together, with a difference of an odd number of half undulations, and thus neutralizing each other by interference; N the resultant red light.

In the lower diagram, fig. 141 may be seen what takes place by turning the analyzing tourmaline one-quarter of a circle. H represents the polarized beam split into two rays; I the tourmaline turned so that its axis is at right angles to that in the preceding figure; K the waves $R^o R^e$ of red light destroying each other by interference; LM the waves, $Y^o Y^e$ and $B^o B^e$ for yellow and blue, meeting together in the same state of vibration, and by their coincidences, waves of doubled intensity for yellow and blue light; N green light resulting from the mixture of the yellow and blue light respectively. By substituting Nicol's prisms for the two plates of tourmaline, and by the addition of an object-glass and eye-piece, the diagrams would then represent the passage of the light through an achromatic compound microscope. If, instead of the selenite, other crystals, such as Iceland spar, quartz, nitre, &c., cut in the manner described at page 220, be placed between the tourmalines, coloured rings will be produced, which, in some cases, may be intersected either by a black or white cross, according as the light is stopped or transmitted. All substances, whether animal, vegetable, or mineral, which, by the unequal arrangement of their particles, possess the property of double refraction, will, when placed between the prisms, exhibit colours varying according to the otherwise unappreciable difference of density of their various parts, and these differences may thus be distinguished and traced out

much more satisfactorily than by common light. "Should, however," says Mr. Woodward,* "the doubly refracting properties of the tissue be too feeble to produce a sufficient difference of colour, the effect may be considerably increased by placing the object on a plate of selenite of uniform thickness, for which purpose a thickness capable of producing a bright purple or light blue colour will be found to afford the most agreeable contrast, and, as a single plate, to be the most generally useful."

In the preceding description of the colours produced by polarized light, those of which mention has been chiefly made are the red and the green; it must not, however, be imagined that these are the only colours, for, in practice, it will be found that not only every colour of the spectrum, but every variety of tint of each of these primary colours will be produced by variations in the thickness of the doubly refracting substance, through which the polarized light passes; these tints may be classified into seven orders, as was done by Newton, when he ascertained the thickness of coloured plates, and particles of air, water, and glass. Selenite, from the circumstance of its splitting easily into laminæ, may be obtained of all thicknesses, and films of intermediate thicknesses, between $\cdot 00124$ and $\cdot 01818$ will give all tints of colour between the white of Newton's first order and the white arising from the mixture of all the colours. The same variety of tints may be produced by placing the films one over the other; for this purpose, Mr. Darker, who has paid considerable attention to the subject of polarized light, and to whose ingenuity we are indebted for some of the most beautiful of our apparatus for exhibiting certain phenomena, in connection with this subject, has devised the instrument represented by fig. 142. It consists of a plate of brass, four inches long, an inch-and-a-half broad, and one-fifth of an inch thick, having a piece of raised brass screwed to it, against which objects may rest when the microscope is inclined; in the centre of the brass plate, there is a hole, one inch in diameter, into which is fitted a ring of the same metal, with a shoulder on its under

* *Op. Cit.*, p. 25.

side to receive certain cells, into which plates of selenite are fitted; this ring is capable of being revolved either to the right or the left of a central index or dart, by means of an

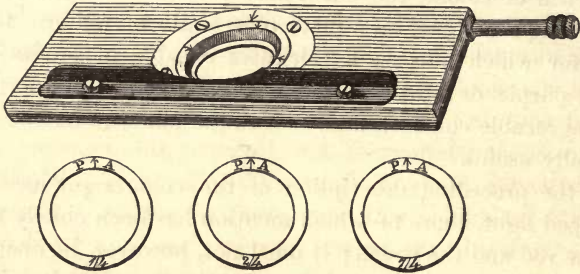

Fig. 142.

endless screw, turned by the small handle seen on the right side of the figure. $PA \frac{1}{4}$, $PA \frac{2}{4}$, $PA \frac{3}{4}$, represent three brass cells, into each of which are burnished two plates of thin glass, having between them films of selenite of different thicknesses. The dart at PA denotes the direction of the positive axis of the selenite, and the figures $\frac{1}{4}$, $\frac{2}{4}$, &c., denote the parts of a vibration retarded by each disc, which, by their super-position and variation in position, by means of the endless screw motion, produce all the colours of the spectrum.

Advantages of Polarized Light to the Microscopist.—The application of this modification of light to the illumination of very minute structures has not yet been fully carried out, but still there is no test of differences in density between any two or more parts of the same substance that can at all approach it in delicacy. All structures, therefore, belonging either to the animal, vegetable, or mineral kingdom, in which the power of unequal or double refraction is suspected to be present, are those that should especially be investigated by polarized light. Some of the most delicate of the elementary tissues of animals, such as the tubes of nerves, the ultimate fibrillæ of muscle, &c., are amongst some of the most striking subjects that may be studied with advantage under this method of illumination. It would be impossible, in a work like the present, to give a long list of objects that require the

aid of polarized light for their exhibition; every structure that the microscopist is investigating should be examined by this light, as well as by that either transmitted or reflected; objects mounted in Canada balsam, that are far too delicate to exhibit any structure under transmitted, will often be well seen under polarized, light; its uses, therefore, are manifold. Those who would wish to enter scientifically into this subject, should consult the works of Biot, Brewster, Herschel, and the excellent *Lectures* of Dr. Pereira; the *Familiar Introduction to the Study of Polarized Light*, by Mr. Woodward, may also be studied with very great advantage. The object of the author in the present chapter has been to show the nature of the apparatus employed, how it is adapted to the microscope, and the method of using it, together with as short an explanation as possible of some of its most important principles; the mode of preparing such objects as will best exemplify these principles will be fully described in a subsequent chapter.

CHAPTER VII.

GONIOMETER.

FOR the purpose of measuring the angles of crystals, whether microscopic or others, a very beautiful instrument has been invented by Dr. Leeson, and has been termed by him, a Double Refracting Goniometer. A full description of it has been given in the *Proceedings of the Chemical Society*, Part XXIII, of which the following is a transcript:—

“The goniometer, invented by the author, with a view to remove many of the difficulties incident to the instruments heretofore in use, is represented in figs. 143 to 151. Amongst the peculiar advantages of this instrument may be enumerated its capability of measuring opaque and imperfect crystals, also microscopic crystals, and crystals in the interior of transparent media. It is equally applicable to the largest crystals, and

will measure angles without removing the crystal from a specimen, provided only the whole is placed on a suitable adjusting stage. The instrument depends on the application of a doubly refracting prism, either of Iceland spar or of quartz, of such a thickness as will only partially separate the two images of the angle which it is proposed to measure.

“Premising that the goniometer may be either mounted as a separate instrument or attached to a microscope, it is proposed to describe it as when fitted to a body of the improved compound microscopes in common use. The same letters will be used for the corresponding parts in figs. 143 to 148, which represents the various parts of the goniometer fitted up as the eye-piece of a microscope, together with those of the adjusting stage to support the crystal which is intended to fix upon the traversing stage of the microscope.

“Fig. 143 is a perspective view of the goniometer, and fig. 144 is a section of the same. At *a* is an achromatic prism of

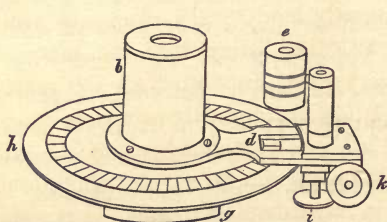

Fig. 143.

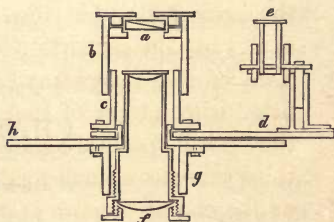

Fig. 144.

double refracting Iceland spar—a Rochon's prism of quartz may be substituted; *b* is a brass tube containing the prism, with a round aperture forming the cap of the eye-piece, and sliding stiffly on the tube *c* attached to the arm *d* carrying the vernier of the graduated circle *h*. At *f* is an achromatic eye-piece, either Huyghenian or positive, sliding stiffly or screwing into the tube *g* which fits into the tubular body of the microscope. If the crystal is large, and no magnifying power required, this eye-piece may be dispensed with; a single lens of long focus may occasionally be substituted with advantage. The vernier has a clamping screw at *i* and an adjusting screw

at *k*. A reading microscope, placed at *e*, is attached to the vernier. Fig. 145 is the adjusting stage to support the crystal whose angles are to be measured, and fig. 146 is a

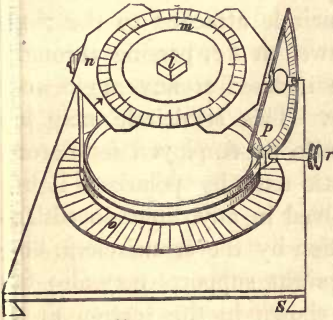

Fig. 145.

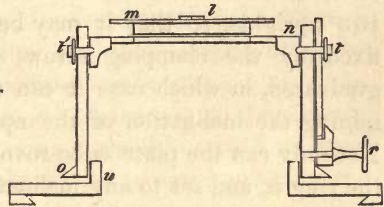

Fig. 146.

section of the same. The crystal may either be attached by Canada balsam or wax to a glass, or blackened ivory plate *l* dropping into the ring *m*, which again fits into the ring *n*, or the crystal may be conveniently held by the clamping arms in fig. 147, attached to a ring, also fitting into the plate *n*. Two of these arms have very small cups at their extremity fitted with a piece of India rubber or cork, by means of which they can be pressed against a crystal without bruising it. The third arm has a small fork at its extremity, which turns round on the end of the arm at *x* in any direction to suit the crystal.

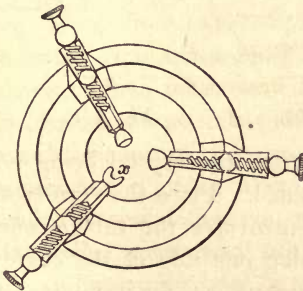

Fig. 147.

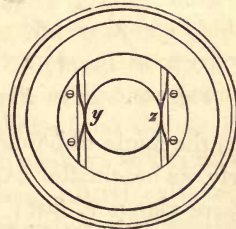

Fig. 148.

The arrangement of screws and guides shown in the drawing is for the purpose of sliding the arms to and from the centre

where the crystal is to be fixed. Fig. 148 is another ring fitting into n with two light springs to hold a slip of glass on which to fix a crystal when desired, or to carry one of the ordinarily mounted microscopic specimens.

“ p , figs. 145 and 146, is a semicircle attached to the ring n , which is centred on two screws, at $t t'$, passing through two uprights, so that it may be inclined at any angle and fixed by the clamping screw r . This semicircle may be graduated, in which case it can also be employed for determining the inclination of the optic axes by polarized light. Not only can the plate m be revolved in any direction within the ring n , and set to any inclination by the semicircle p , but the whole ring o carrying the upright supports may also be revolved around the short tube shown in the section at u upon the plate s which fits upon the traversing stage of the microscope. The ring o may also be graduated, if thought useful, and thus rendered convenient for investigations by means of polarized light.

“When a crystal, or any angle thereof, is viewed through the prism attached to the goniometer, two images thereof are produced by revolving the prism, which, with respect to each other, may be made to occupy various relative positions, as shown, for example, in figs. 149, 150, 151. Let $a b c$, fig.

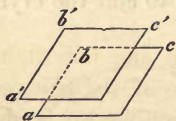

Fig. 149.

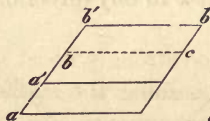

Fig. 150.

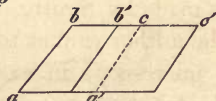

Fig. 151.

149, be the angle to be measured, the crystal being adjusted properly, as hereinafter explained. Place the vernier at zero, and there clamp it fast; then revolve the tube b containing the prism until the lines forming one side of the angle to be measured coincide in both images, as, for instance, the lines $a b, a' b'$, fig. 150; then release the vernier and revolve it on the graduated circle, until the two lines forming the other side of the angle $b c, b' c'$ also coincide, fig. 151. The amount of

rotation thus obtained is the measure of the angle, or its complement, according to the direction in which the vernier is moved. Instead of starting from zero, it is of course sufficient to take the difference of the readings in the two positions.

“ There are two descriptions of angles, the one sort being the plane angles produced by the lines forming the edges of the planes, the other sort being the angles representing the inclination of the planes themselves to each other.

“ When a plane angle is to be measured, it is necessary that the two lines or edges forming it should be both situated in a plane perfectly horizontal, that is perpendicular to the axis of vision. The stage, fig. 145, furnishes every facility for this adjustment, which may be known to be perfect by using a suitable object-glass and observing that every portion of both lines remains exactly in focus on traversing the stage.

“ When the inclination of two planes is to be measured, they must be so adjusted that their line of junction is parallel to the axis of vision, or, to use a familiar expression, they must be taken out of winding, as it is termed. A very little practice will satisfy the observer that these adjustments may be readily accomplished by the stage in question.

“ Similar adjustments may be effected, although somewhat more difficult, by using the forceps commonly sold with the compound microscopes, more especially the three-pronged forceps made by Smith.

“ The author cannot too strongly insist on the importance of the microscope in examining the surface of the planes of crystals subjected to measurement, convinced as he is that obliquity in many cases arises not only from conchoidal fractures, but also from imperfect laminae elevating one portion of a plane, and yet allowing a very tolerable reflection when measured by the reflective goniometer. Another source of error sometimes arises from not observing that the planes measured are those of maced or aggregated crystals, and thus furnish angles which would not exist in a distinct crystal.”

Mr. Ross has also contrived a very excellent goniometer; it is constructed somewhat on the same principle as the

micrometer eye-piece, shown at fig. 123, page 192, by placing a cobweb in the lower part of the outer tube in the focus of the eye-glass, instead of a divided scale, and having the upper rim of the same tube divided into 360° . By turning either the crystal or the cobweb, so that one of the sides of the former may lie in a line parallel with the cobweb, and having set the index at zero, or observing the degree it points to, and then bringing the cobweb in a line parallel with another side of the crystal, the number of the degrees passed over will give the angle required.

PART III.

MANIPULATION.

MANIPULATION.

CHAPTER I.

THE microscope, and all the apparatus necessary for the investigation of every class of object, having been fully described in the preceding pages, it remains now to point out the different methods by which these objects may be exhibited, as well as mounted and preserved for future examination. As this work is chiefly intended to afford information to those who are young in microscopical science, and who, therefore, cannot be supposed to be familiar with many of the methods employed in the preparation of the different kinds of objects, the author must be excused for entering somewhat in detail into a few of the most important processes, as it is requisite that the directions given should be sufficiently plain to enable even the most inexperienced manipulator to carry them into effect.

All structures intended to be viewed by transmitted light requiring glass of some form or other, either for their support whilst being investigated, or when permanently mounted, it becomes necessary first to allude to the best mode of cutting such glass into the proper shape by a diamond.

Diamonds for Cutting Glass.—The diamonds required by the microscopist are two in number, the plough or glazier's diamond, and the writing diamond. The former is necessary for cutting the thin plate or crown glass for slides, and for cells and boxes to mount objects in, whilst the latter is required for cutting the thin glass for covers, and for writing the names of the objects on the end of the slides. The plough or glazier's diamond is represented by fig. 152, and consists of a shaft or handle, and of an oblong piece either of

steel or brass, in which the diamond is set; this piece of metal is connected to the handle by means of a swivel joint which works in the end of a brass ferrule attached to the handle of the instrument. The handle is generally composed of wood or ivory, the upper part is round and slight, whilst the lower part is much larger, and flattened on two sides, for reasons presently to be assigned. The amateur, when taking a diamond in hand for the first time, must not be disappointed if he fail to cut a strip from a piece of glass: he may even persevere, and still some time elapse before he is certain of making a good cut—hence it has been thought that a few words of instruction on this point would not here be out of place. The diamond should be held in the hand thus:—The upper part of the shaft or handle should be placed between the fore and middle finger, and one of the square sides of the lower end pressed upon by the thumb, and the opposite square side by the fore-finger. The side of the oblong piece of metal in which the diamond is set should now be brought against the edge of the ruler, and by means of the swivel-joint it will readily accommodate itself to it. And supposing we wish to cut a strip from a piece of glass, we must first lay the ruler on the glass, in the position in which we wish the cut to be made; the diamond held as already directed must be placed against the edge of the ruler, at the spot

Fig. 152.

where we wish the cut to commence; and should the operator have never cut with the same diamond before, he should rest it on its point, and move it backwards and forwards upon it, making the upper end of the handle describe a curve, until the diamond marks or takes readily to the glass. When the right position is obtained, the diamond may be drawn carefully along the ruler to the opposite end of the glass, care being always taken that the pressure exerted on it be not great, and that the same degree of inclination of its

handle to the ruler be preserved throughout, else in parts the glass will be cut, and in others only scratched. A true cut will be known by being very faintly visible, and by a particularly musical sound being produced by the cutting, whereas a scratch is known by its jagged edges, and by the rough and harsh sound made whilst the diamond is passing: when the glass is held towards the light, it will be seen that the scratch is merely superficial; but the true cut, although faintly seen on the surface, will show that the glass is cracked for some considerable distance below it. When we try to separate the slip which has been cut with the diamond, we shall find that it easily breaks off, whilst the scratched portion will be with difficulty, if at all, removed. The operation of cutting, although at first sight very simple, will be found not to be so in practice. The best plan for the tyro is to procure a piece of soft glass, and make a number of cuts as near to each other as possible, and try how thin a slip can be broken off.



Writing Diamond.—The writing diamond is represented by fig. 153; it is not provided with a swivel, neither is the handle squared, but consists for the most part of a thin, tapering stem of ebony or ivory, and as it, like the glazier's diamond, will only cut or scratch in certain positions, it is requisite that the operator should ascertain this point, and when once found, a mark should be made on the handle, in order to show which part of it is to be held in front. Those diamonds having a portion of the handle squared on which to place the thumb or forefinger will be found to be by far the most convenient; but when the operator has once fixed upon the best writing point of the diamond, he may, if he chooses, cut out a place in the handle for the reception of the thumb or forefinger. There are two descriptions of writing diamonds, one in which an irregular stone has been ground or turned to a fine point, whilst the other is formed of a sharp-pointed fragment or splinter. The former is to be preferred, although its cost is considerably greater.

CHAPTER II.

ON CUTTING GLASS.

Glass.—The best kinds of glass for mounting objects upon, are those known in commerce as *thin plate* and *flatted crown*, both may be purchased either in sheets or cut up into slides ready for use; if the former be preferred, it should be free from holes and flaws, whilst, in the latter, veins and air bubbles must be avoided; should the operator wish to cut it himself, he must be provided with a diamond of the form represented in page 240, and with a piece of apparatus termed a cutting-board.

Cutting-board.—This is represented by fig. 154, it consists

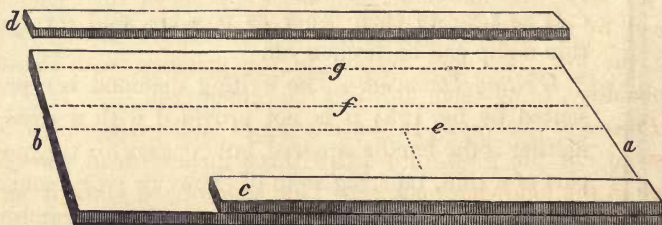

Fig. 154.

of a piece of mahogany or deal *ab*, about a foot or eighteen inches long by eight or nine broad, and three quarters or one inch thick; upon this, and close to one of the sides, is screwed a strip of similar wood *c*, about an inch broad and one-fourth of an inch thick, but not so long as the bottom piece by two inches; upon it may be marked lines, such as *efg*, to indicate the width of the more common sized slides. The rulers are generally made of the length of the board, and as broad as the sizes of the glass-slides required to be cut, minus the thickness of the setting of the diamond; the wood most suitable for them is from one-eighth to one-fourth of an inch thick; one of these rulers is represented by *d*. In all, the ends should be cut perfectly square, for a purpose presently

to be named. Now supposing we wish to cut the slides of the usual size, viz., three inches long by one inch wide, we must be provided with two rulers, the one not quite one inch broad, the other not quite three inches, as no diamond will cut close to the edge of the ruler, in consequence of its being set in the middle of a piece of steel or brass, therefore the distance of the cut, made by the diamond-point from the edge of the ruler, will be regulated by the thickness of the setting; and as no two are of the same thickness, it becomes necessary to have the rulers, at first, of the respective breadths of one inch and three inches, and then to have one edge planed, until the cut made by the diamond is exactly the right measure. When those who use plate-glass prefer having the edges of their slides either ground or polished, it is as well to keep the rulers of the exact size of the slide, viz., one of an inch and the other of three inches broad, by these the slides will be cut larger than is required, but the loss the edges sustain in the grinding will, in all probability, bring them down to the proper size.

Process of Cutting.—In the cutting of slides, it is advisable first to cut the glass into strips three inches broad, this is done in the following manner:—One edge of the glass, if not quite straight, is to be made so by cutting a thin strip off; this straight side is to be placed against the thin raised edge on the cutting-board, and pressed firmly towards it; the broad ruler is then to be laid upon the glass, and also pressed against the raised edge, and a cut, made with the diamond in the manner previously described; we shall now have a strip of glass three inches broad. The next step is to make one of its ends square, this may be done by laying the strip against the raised edge of the cutting-board, with one extremity extending a little beyond it, the broad ruler, being perfectly square at both ends, is now to be placed with one of these against the raised edge and a cut made, this will render the end of the strip of the glass square; this squared end is now to be brought against the edge of the cutting-board, and, with the narrow ruler, it can be cut up into as many slides of three inches by one as its length will admit of; when these are

placed in a bundle, they will be found to be all of one size, which would not be the case were any other plan adopted. The small strips cut off from plate-glass, which are not large enough for slides, should not be thrown away, as they will be found very useful in making cells or boxes. It will be noticed that slides of three inches by one have only been spoken of in the preceding description, of course any other sizes may be cut by the same process, by having rulers of the requisite breadth.

Edging the Slides.—All glass that has been cut with the diamond will present a rough edge, to obviate this, and at the same time to improve the appearance of the slide, the edges must be ground smooth, this is done by rubbing them on a perfectly flat plate of metal, with fine emery and water. As one of these plates will be found of great use for other purposes than that just mentioned, it will be as well here to speak of the best form to be adopted. Several metals will answer the purpose, but the best is a mixture of lead and pewter; cast-iron and brass, especially the former, will answer very well, but lead is rather too soft; in order to get the surface flat, it may be planed, or, if the plate be not very large, three of the same size should be procured; they may all be kept perfectly true by a process well known to most mechanics, this is nothing more than grinding one alternately against the two others, and these two against each other, whereby a perfectly flat surface may be always kept. If cast-iron is employed, three plates, about seven or eight inches in diameter, will answer the purpose exceedingly well. The process of grinding the edges consists in holding the slide in a vertical position on the plate, and rubbing it either round and round, or else backwards and forwards, until perfectly flat; if the edges require to be bevelled, the slide must then be inclined at an angle of 45° with the plate, and be rubbed in the same manner. The emery should be fine, and the slide dipped in clean water occasionally, and then wiped to see how the grinding proceeds. To receive the excess of emery and water, which is sure to escape over the side of the plate, a cloth may be placed around it, or, what is best, is to have the plate

fixed into a block of wood in the same manner as a hone. If the edges require to be polished, after having been ground, they may be rubbed upon a flat piece of wood covered with buff leather, that has been impregnated with putty powder, water being used in the same manner as with the emery. If a large quantity of slides are required, the process of grinding will be facilitated by employing a lapidary's wheel or mill, charged with emery; the polishing may also be done in the same apparatus by using a wooden wheel charged with putty powder. If the slides are intended to be covered with paper, the grinding of the edges may be dispensed with, as the paper will hide all inequalities of surface.

ON CUTTING THIN GLASS FOR COVERS, ETC.

The thin glass employed to cover microscopic preparations is manufactured only by Messrs. Chance, of Birmingham, it may be procured of various degrees of thickness, from the one-twentieth to less than the one-hundredth of an inch; being unannealed, it must, on account of its brittleness, be handled with care. For cutting it, the board described at page 242 for the thick glass may be used, or a smaller one, consisting of a piece of mahogany about eight inches long, three broad, and a quarter of an inch thick, with a raised edge, as represented at *c*. The lines *efg*, in front of the raised edge, should also be present to indicate the length and breadth of two slides of the size most commonly used, and to form a guide for cutting the covers. As it matters little if the covers are not cut exactly of the same size, one narrow ruler will generally suffice for all purposes.

The diamond to be employed must be the writing one, having a sharp point, but the pressure exerted ought to be slight, as the thin glass, from not being annealed, is apt to break with the slightest touch; should the operator, however, not be provided with a writing-diamond, the glass may be cut with a plough-diamond by the following means, viz., by laying it on a piece of plate-glass that has been wetted, this will fill up all inequalities and cause an adhesion between them, and, with a

little care, the diamond-point will cut it, but if the first stroke fail, the operation must be repeated until a scratch is made; as it often happens that, from the hardness of the surface of the unannealed glass, a plough-diamond will not readily mark it.

To Cut Circular and Oval Covers.—This may be done either by a machine in which a plane surface of wood, on which the glass is laid, is made to revolve either in a circle or oval underneath a diamond-point, or by the writing-diamond; in which latter case a model of the size of the cover will be required. In order to cut circles, the following plan may be adopted:—Discs of metal of various sizes should be selected, one of these being laid upon the thin glass, and pressed firmly down with the finger, the diamond is to be passed round the margin of the disc, care being taken that, in the passing round, it be made to revolve on its own axis, otherwise the beginning and end of the cut will not join, a little practice will soon overcome this obstacle. When a number of discs of the same size are required, it is advisable to have the thin glass cut into strips a little broader than the circles are to be, the circles when cut can then be readily separated from the surrounding glass; but should any difficulty arise, a few strokes made by the diamond through the largest and most attached parts, will readily cause their separation. Another plan is to select a set of sections of glass tubes of different sizes, and to lay one of them on the thin glass, the diamond may then be passed either on the outer or inner side of the ring, in the same manner as when the metallic disc is used. When oval covers are required, we may either use a model, cut out of card-board, or select some of the truest of the oval cells that are used for mounting preparations in, and proceed with them as with the metal discs and glass rings. Much of the thin glass used for covers is slightly curved, care, therefore, is required to select those pieces that are the flattest, especially when the covers are destined for cells containing fluid; if they are not flat, the gold-size, or other material employed to cement their edges, will be certain to run underneath them. When the edges of the covers, whether circular or otherwise, are not cut

sufficiently well to allow of the fragments being separated from them readily, but little pieces of glass are left behind, it will then be necessary to employ a fine file, this, when rubbed over the edges, will make them smooth, and any of the cements will adhere more firmly to them. For this purpose the cover should be held between the thumb and first finger, and only a small portion of the edge allowed to project above the fingers for the file to act on at a time, by these means there will be but very little risk of fracture.

CHAPTER III.

METHODS OF CEMENTING CELLS.

THERE are three principal methods of mounting microscopical preparations:—first, in the dry way; second, in some kind of preservative fluid, such as spirit and water, or Goadby's or other solution; and third, in Canada balsam. In the first method, all that is generally required is a slip of glass or a slide (as it is commonly termed), and a cover of thin glass; but, in the second method, when the object is of any thickness, the fluid requires to be contained in some kind of reservoir, this is most frequently made of glass, and is called by microscopists a *cell*; of these, various shapes and sizes will be found necessary, but as all require to be fastened to a slide, by means of some kind of cement, it will be as well here to describe the most approved methods of conducting the operation.

Method of Cementing Cells without Heat.—The thin glass, the tubular, the drilled, and all the other forms of cells presently to be described, may be fastened to a bottom glass or slide by means of one or other of the following cements, viz., a mixture of gold-size and lamp black, or gold-size and litharge or red-lead, or a solution of asphaltum in turpentine; in all these cases, the parts of the cell that are to be cemented must be simply painted over with a tolerably thick layer of one of the above cements, and then be laid on the slide, and

be put aside until the cement is sufficiently hard for the cell to be used ; this will often require many days.

Cementing Cells by Heat.—The most efficacious plan, however, is to employ one of two substances known in commerce as Canada balsam or marine-glue, both of which must be liquefied by heat, and, to effect this, a simple apparatus, such as a small plate of sheet-iron, supported in some way or other over a lamp, must be provided. The size of the iron-plate should be large enough to hold slides three inches long by one wide ; it can be supported in various ways ; if the plate be about five inches square, it may very well be heated, either upon the ring over a chemical argand lamp, or upon one of the rings of a retort-stand, and a spirit lamp used. By far the best plan is to have a piece of wrought iron about six inches long, two and a half inches broad, and one-eighth thick, as shown in fig. 155, with a small wire leg screwed into each

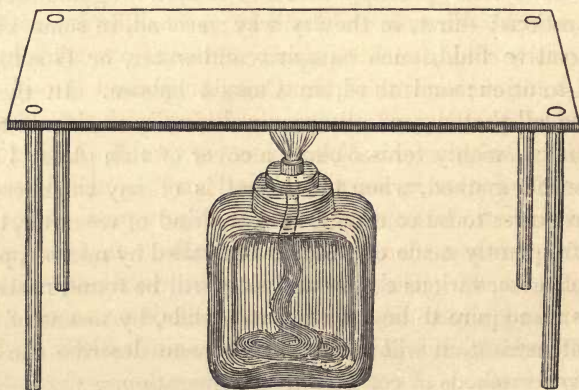

Fig. 155.

corner to support it, about three inches from the table, and under this, a small spirit lamp may be placed to heat it.

Whilst the plate is being made warm, the cell and the slide, to which the cell is to be cemented, are to be laid upon it ; and on the sides of the cell small pieces of marine-glue, cut either into lumps or shavings, are to be placed ; these must be watched, and as soon as they begin to melt, they may

be moved one towards the other, with a sharp-pointed instrument, so as to cover the whole of the surface which is to be cemented; as soon as this is done, and the glue is seen to boil, the cell may be taken up with a pair of forceps and turned over upon the slide, and when it has been adjusted to its right place, the cell may then be firmly pressed down upon the slide with a piece of flat wood, so that all the superfluous glue, with any air bubbles that are present, may be squeezed out. The cell may now be removed from the plate and placed upon a piece of wood; before it gets cold the superfluous glue may be scraped away easily with a small chisel, such as represented by fig. 156, or by a knife; but if this operation be left until the



Fig. 156.

cell is cold, the task then will be more difficult; as soon as the cell is cold, a small quantity either of a weak solution of potash, or even spirits of wine, may be poured into it, and all the small particles of glue removed first with the chisel, and, secondly, with a chisel-like piece of wood, having a thin piece of rag over it, so that the cell may, by these means, be freed both from the cement and from any greasy matter that may be present (care being always taken that the glass be not scratched). The cell may now be rinsed out with clean water and wiped dry, first with a cloth or an old cambric handkerchief, and finished with chamois leather; it is now ready for use.

When the glue has been heated too much, it turns black, becomes tough, and will not stick to the glass; when this has happened, it is better always to take away the cell, scrape off all the old glue, and begin afresh, than to attempt to cement it with glue that has been over heated and has lost its fluidity. As soon as the glue boils, then no time should be lost in laying down the cell in its proper place. Sometimes small black gritty masses are present in the glue; these should be removed whilst the melting is going on, as when they are left,

unless they can be crushed by pressure, they will prevent the cell from coming down flat on the glass, and often large air bubbles will appear when the pressure is taken off. There are many kinds of marine-glue in use, but the best for cementing cells is that known in commerce as G. K. 4, this melts at a temperature some few degrees higher than that of boiling water, the harder kinds get brittle by keeping, and their melting point is much higher. While the plate is warm, and all the materials are at hand, it is by far the best plan to cement a number of cells, all of which may be cleaned and put by ready for use, as it will be found in practice highly necessary to have several sizes in store, that an object may be mounted speedily, for many valuable things are laid by and forgotten when the trouble of making and cleaning a cell has to be gone through before the mounting can be accomplished.

To Cement Cells with Canada Balsam.—The iron plate, the spirit lamp, and the tools mentioned in the article on cementing cells with marine-glue, will all be as requisite for the Canada balsam as for the former material. The plate is also to be warmed, and the cells laid on it, as there described; but upon the sides of the cell some old but semifluid Canada balsam is to be placed, as soon as it shows the least symptom of boiling, which is known by the disappearance of all air-bubbles, it may be taken up with the forceps and laid upon the slide, pressed to get rid of the superfluous balsam, and then set aside to cool; the superfluous balsam may be removed with the knife or chisel, and the cell may be cleaned with a rag, dipped either into turpentine or ether. To get rid of these, the potash or alcohol may be substituted, and when the cell is rinsed out with clean water, and wiped dry with a rag and chamois leather, it is ready for use. Canada balsam is not so good for the cementing of cells as the marine glue, in consequence of its getting brittle by age; some considerable care even is required in handling preparations that have been mounted only a few years, as the least jar or bending of the slide to which the cell is cemented, is often attended with a separation of the balsam.

It should always be borne in mind that the heated slide to

which the cell has been cemented must not be touched with a damp hand, neither should it be laid on metal or anything wet, as the glass, when suddenly cooled, is very apt to crack. Should the upper part of the cell be uneven, it should be rubbed on the metal plate described at page 244 until it is perfectly level, as the success of the operation of cementing down a cover will materially depend upon this point.

CHAPTER IV.

METHOD OF MOUNTING OBJECTS IN FLUID.

ALL very delicate animal and vegetable tissues, to exhibit their structure clearly, should not be mounted in the dry way or in Canada balsam, but in some preservative fluid, such as spirit and water, Goadby's solution, or one or other of the fluids which will be presently enumerated.

The most minute structures, such as the vessels of plants, the muscular and other tissues of animals, requiring in all cases exceedingly high powers for their due exhibition, must of necessity be preserved in very thin cells, with a small amount of fluid.

The best method is as follows:—Take a slip of thin plate glass, of the size adopted by the Microscopical Society, viz., three inches long by one broad, or any other convenient size, and after having cleaned it thoroughly by washing with a dilute solution of caustic potash, to remove all grease, let it then be laid flat, and a drop of one or other of the preservative fluids presently to be enumerated be placed upon it; in this the object is laid, and after having been properly spread out with the needle point, it is ready to receive its cover of thin glass. This cover should be selected with care, and should be as thin and as flat as possible, and when freed from all grease by being rubbed with caustic potash, it should be wiped with a clean cloth or chamois leather, and when finished

should be held in the middle, not with the fingers, but with forceps. The next part of the process is to touch its edges slightly with one or other of the cements presently to be enumerated (the simple gold-size will be found to be the best, as it is most free from colour), the cover being held with the forceps, the brush, with a very small quantity of the gold-size, may be gently passed along each of its edges. The next thing to be done is to lay the cover upon the object; this is effected by dropping the cover gently upon the fluid, and pressing it lightly to exclude all the excess, and to leave only



Fig. 157.

a thin stratum intervening between the two glasses; the excess may be removed either by drawing it away by the sucking tube, fig. 157, or by small slips of blotting-paper. After this operation is finished, a thin layer of cement is to be placed where the edges of the cover come in contact with the bottom glass; when this is dry, another thin layer may be put on, until the angle between the two glasses is nearly filled up. The use of anointing the edges of the cover with the cement before laying it on the fluid is two-fold, first, to prevent its getting wet, and by that means hindering the cement from sticking, and secondly, all moisture being repelled by the greasy cement, the next layer applied will adhere more firmly. Care must be taken to exclude all air bubbles from between the cover and bottom glass, otherwise the cement will run in, especially when the bubbles are near the edge; should too much of the fluid have been drawn out from between the glasses, and an air bubble be left, it is then necessary to add a little more of the fluid at the edge where the bubble is, and it will then run in and occupy the place of the bubble, and the excess of fluid may be again taken away in the manner before described. Objects mounted in this way seldom keep very long, and when once an air bubble has made its appearance, it becomes necessary that a watch

should be kept upon it, lest the cement also run in and spoil the specimen. When an object possesses any appreciable thickness, it is by far the best plan not to mount it in this way, but to adopt one or other of the following methods, in all of which a small reservoir is employed to contain both the fluid and the preparation; this reservoir is termed a *cell*; various forms of these, which will be particularized as the thin glass cell, the concave, tubular, and drilled cells, with many others, here require separate mention.

In order to prevent the cement employed in the flat cell from running in to spoil the object, the author's late brother, Mr. Edwin Quekett, adopted the plan represented by fig. 158, which was to take a piece of writing paper, about

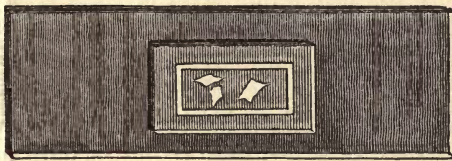

Fig. 158.

one-eighth of an inch smaller each way than the cover to be employed, and from the middle of this to cut out a square or circular hole sufficiently large to hold the object.

After the fluid had been placed on the slide, and the object deposited in it, this paper cell was also placed in the fluid, and when adjusted to the centre of the slide, the cover was laid on in the usual manner, the paper preventing the cement from running beyond it to obscure the object. Following out this principle, Mr. Darker has ingeniously contrived a cell of the form represented in plan by A B, fig. 159, and in section by C.

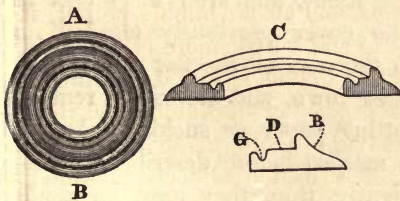

Fig. 159.

These cells are cast in glass of the size represented by A B, and, in order to prevent the cement from running in, the sides are constructed as shown by G D B. B being the outer margin of the cell, D a flat surface for the cover to rest on, and G a groove between it and

the cover to rest on, and G a groove between it and

the inner margin. These cells are cemented to the slides in the usual manner, either with marine-glue or asphaltum dissolved in turpentine, the method of cementing down the cover is the same as in the other forms, a small quantity of gold-size being laid on the flat surface on which the cover is destined to rest before the fluid is placed within the cell; should there be any tendency in the cement to run under the cover, it must first fill up the groove before it can get into the cavity where the object is. The under surface of this form of cell can be ground sufficiently thin to enable a quarter of an inch object-glass to view any object contained within it.

The Thin Glass Cell.—This is represented by fig. 160, and consists, as its name implies, of a piece of thin glass, such as is used for covers, about three-quarters of an inch square, out of which a round hole, varying from one-half to five-eighths of an inch has been drilled. In order to make this useful, it is to be cemented to one of the slides of plate-glass with marine-glue, in the manner previously described at page 248.

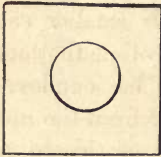

Fig. 160.

After the cell has been properly cleaned, as there directed, it is ready to receive the intended object, which is to be mounted as follows:—A small quantity of gold-size is to be placed upon the margins of the cell, and as much as possible wiped off with the finger (taking care that the size is wiped away from the hole of the cell and not towards it); the fluid in which the object is to be mounted must now be placed in the cell (and it is always a good plan to put in rather more than is used), and after the object has been properly arranged, the cover previously cleaned and anointed on its edges, as in the case of the flat cell, is to be laid on the fluid and pressed down, and the excess removed from its edges by the blotting paper or sucking tube, and the cement laid on in the manner before described. When these cells are not sufficiently thin, they may be readily made so by rubbing them down on the metal plate described in page 244, with some fine emery and water. It is a good

plan always to give them a rub on the metal, not only in order that they may be rendered flat, which they rarely are, but because a ground surface is calculated to give firmer hold to the cement than one which is polished.

The author prefers this form of cell to any other, even for the most delicate tissues, and both cell and cover can be made so thin, that an eighth of an inch object-glass can be used. The flat cell, however carefully prepared, is almost certain to leak after a time, and, from its containing such a small amount of fluid, a very short period will elapse before the object within it is found perfectly dry; but in the thin glass cell there is more fluid, and any leaking is made evident by the formation of an air bubble; when the bubble gets very large, the cover can easily be removed, and the object re-mounted without its having first been allowed to get dry.

The Concave Cell.—This consists of a slide of plate-glass, rather thicker than ordinary, in the centre of which a concave cell or pond has been ground out, and either left in the rough state or polished, it may be either of the form represented in fig. 161, or fig. 162; the method of mounting objects in it is

Fig. 161.



Fig. 162.

the same as in the flat cell, with the exception of a thin layer of the gold-size or other cement being placed around the margin of the depression, as in the case of the thin glass cell, and wiped off with the finger. The fluid is to

be placed in the concavity, and the cover dropped on as in the preceding descriptions, but the cover should be so much larger than the cell, as to leave a margin of one-eighth of an inch around it. This form of cell, when polished, does very well for many objects where accurate definition of the surface only is required; and, when unpolished, is most useful for thin opaque objects, such as pieces of injection, leaves of plants, &c., &c., that are too thick to be mounted between two flat pieces of glass. A very convenient and durable form of cell

may be made by spreading some old white lead, that has been ground in oil, on one of the slides that measure three inches by one, taking care to leave an aperture or pond in the centre a little larger than the object; the lead may be laid on of a thickness equal to that of the object. Spirit and water, or other fluid, is to be placed in the pond, and the object deposited in it; the thin glass cover, which should be as large as convenient, is to be put on obliquely, and pressed firmly down into the white lead, taking care to exclude all air bubbles. The author has objects in his possession quite perfect, which were mounted eight years ago. Mr. Wm. Valentine, who has adopted this plan for many years with complete success, uses a little trowel, of box or other hard wood, of the shape represented by fig. 163, to plaster down the white lead



Fig. 163.

and press the glass, and a more convenient instrument for the purpose cannot be devised. When Mr. Valentine first commenced this plan of mounting, thin glass was not to be met with; he was, therefore, obliged to use a stout piece of mica; with this his objects have kept perfect for many years. Mr. Holland, whose name has been frequently mentioned as the inventor of the triplet object-glass, has recommended* a cell of the form represented by fig. 164, as useful for many objects that require a high power.

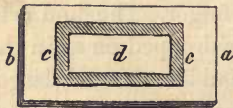

Fig. 164.

ab exhibits a glass slide, on which is painted, with white lead (worked up with one part linseed-oil and three of spirit of turpentine), a pond or cell *cc*, enclosing a space *d*. Glasses so prepared with cells of any size or shape must be allowed to dry before they are used. The method of mounting objects within this form of cell is thus described:—"A drop of fluid containing the object is placed

* Vol. xlviii., *Transactions of the Society of Arts*, page 123.

within the space *d*, and a piece of mica of the same size as the part painted dropped on the fluid; but care must be taken that the drop be not in sufficient quantity to touch the inner margin of the cement. That being accomplished, take some almond oil in a hair pencil, and pass it lightly and slowly round the edges of the mica: the oil will insinuate itself under it, and will surround the object without mixing with it. When the oil is cleaned off, a coating of the white lead may be laid round the edges of the mica, extending about one-tenth of an inch within and without it."

The two following methods of mounting very delicate objects, such as *Desmidiæ*, have been recommended by Mr. Thwaites.* The first consists in marking out on the glass slide a cell of the required shape with gold-size, thickened either with litharge, red-lead, or lamp-black: these materials are to be mixed together on a slab, and laid on the slide as soon as possible, as this mixture quickly becomes hard. In the second, where deeper cells are necessary, marine-glue is used: this must be melted and dropped upon the slip of glass, and flattened when warm with a piece of wet glass, and what is superfluous cut away with a knife, so as to leave only the walls of the cell; these, if they have become loosened, may be made firm again by warming the under surface of the slip of glass. The surfaces of these cells may be made flat by rubbing them on the metal plate with emery and water. The plan of laying down and of cementing the thin cover is the same as that for the flat and thin glass cell before described.

Mr. Topping prepares cells for receiving minute preparations in the following manner:—He takes a slip of glass and lays on it two thin pieces of mahogany of the size of the glass; each has a hole of the required figure cut in the centre; in one piece the hole is the size of the outer margin of the cell, in the other of the inner margin. These, when laid over the glass, afford the means of marking out with a writing diamond the space to be occupied by the cell, which must be filled up with japan. The glass is now to be transferred to an oven, the heat of which should be gradually raised to

* Ralfs' *Desmidiæ*, page 40.

prevent the japan from blistering; but if care be taken in this part of the process, a cell so constructed will resist the action of proof spirit.

When thicker objects, such as injections or other opaque animal structures, require to be mounted, it is necessary to have a much deeper form of cell than any of the preceding; these may be made of all depths and diameters, by having transverse slices cut from glass tubes, and may be denominated the *tube cells*; one of them is shown in fig. 165, and when cemented to a slide in fig. 166. The tube should be rather thick, at



Fig. 165.



Fig. 166.

least one-eighth of an inch, in order that the cells may hold firmly to the bottom-glass. These cells may be made of all diameters between the one-fourth of an inch and an inch-and-a-half—they may be even made larger, if required; the author has had some cut from stout bottles and from the necks of decanters, that are as much as two inches-and-a-half in diameter.

Some exceedingly good and useful cells may be made from glass which has been moulded or cast into rectangular tubes; slices cut transversely from these, of the shapes and sizes shown by the following figures, will be found the most convenient, figs. 167, 168, 169, being for the glass slides of one



Fig. 167.



Fig. 168.



Fig. 169.

inch in width, whilst fig. 170 is intended for the slides, which

are one inch-and-a-half or more in width. These cells are cheaper than those which are drilled in plate-glass, and are

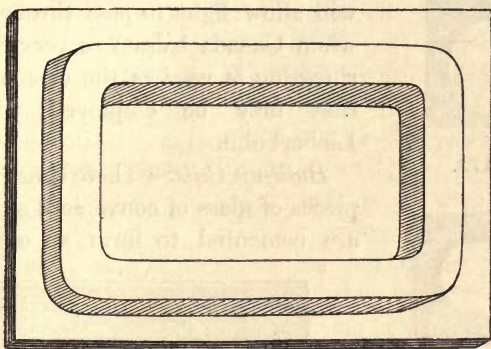

Fig. 170.

quite as neat in appearance. Fig. 171 represents one of this form cemented to a slide and ready for use.

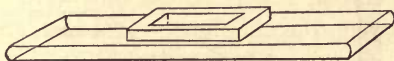

Fig. 171.

Drilled Cells.—These are composed of pieces of plate-glass of any convenient size, out of the middle of which either a circular or oval hole has been drilled, the depth of the cell depending in all cases on the thickness of glass used; when required to be very thick, two or more cells of equal size may be cemented together, either with the marine-glue or Canada balsam; figs. 172, 173, 174, represent three convenient shapes, and figs. 175, 176, 177, one of each cemented to a bottom plate of glass or slide; these cells have many advantages over others, as any number may be made of one thickness, they may also be made perfectly square outside, and yet the cavity or cell within may be either oval or circular, which is often desirable.

The method of cementing them to the bottom glass is the same as that for other forms of cells. Being made of plate-glass

they are very flat and of uniform thickness, which is not always the case with those cut from tubes, and from not being ground on their surfaces, they will allow light to pass through them, when Canada balsam or very thin marine-glue is used as the cement, hence they may be employed with the Lieberkuhn.



Fig. 172.



Fig. 173.



Fig. 174.

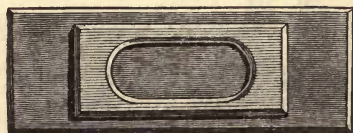

Fig. 175.

Fig. 176.

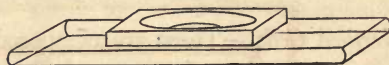

Fig. 177.

square cell. The simplest form, and one which will answer the purpose of either the thin glass cell, or the tubular or drilled cell, when these are not at hand, may be thus made. Take a piece of glass of the required shape and thickness, say one inch long and three-fourths wide, and mark out on it, with a writing-diamond or ink, the size of the cell you wish to make, as *e* in fig. 178, continue the lines to the edge of the glass as shown by dots at *a b c d*. Now, with a cutting-diamond, make four cuts in the direction of the lines *a b*, *a c*; *b d*, *c d*; reject the middle piece *e*; and cement the four outside pieces to the slide in the same manner as one of the other

forms of cell, taking care always to put the pieces in the order in which they were before they were cut off; this is known

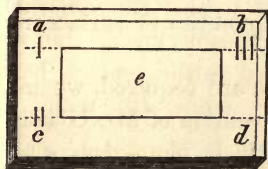

Fig. 178.

by making little marks or lines in each corner, so that, when the pieces are separated, one half of the mark may be on one side and the other half on the opposite, as seen in the above figure; this will serve as a guide to fit the pieces properly together, and when a little

marine-glue is placed between the joints, the four pieces will be held as firmly together as if they were a solid mass. Should, however, the pieces not be brought down to a uniform level, the cell may be rubbed on the metal-plate with emery, and be thus reduced to any convenient thinness. Cells made in this way of the thin glass answer uncommonly well, and, when properly cemented, will form an excellent substitute for any of the other kinds; they may be made of all thicknesses of glass, from that used for covers up to the thickest plate that the operator can cut slips from with the diamond.

Thicker cells, as represented by fig. 179, may be made

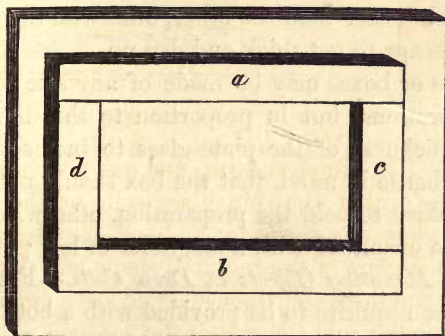

Fig. 179.

of four narrow strips of stout plate-glass, cemented together as in the preceding specimen, upon a bottom piece of thinner plate; but care must be taken that the ends of the sides *cd*, and the edges of *ab* be ground flat, and that the joints be

firmly cemented. Strips of plate-glass from one-eighth to half an inch may be obtained at the looking-glass makers, or may even be cut by the diamond, which will answer for this purpose uncommonly well, as all inequalities of surface may be ground down on the metal plate.

When much deeper cells than these are required, we must have recourse to the glass box, the invention of Mr. Goadby.

This consists of four pieces of thick plate-glass *a b c d*, cemented together upon a bottom piece or slide by their edges, as seen in fig. 180. The edges are ground flat, and the sides

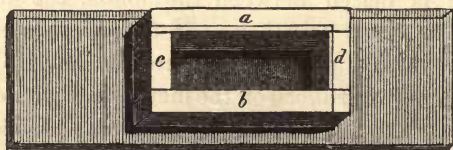

Fig. 180.

c d made rectangular; this form of cell is not so easily cemented as any of the preceding, and when the marine-glass is once melted upon the edges, the pieces should all be put together as speedily as possible, so that one part may not be made much hotter than the other, otherwise the glue, when overheated, is apt to get thick and dry up.

These cells or boxes may be made of any size to suit particular preparations, but in proportion to the dimensions so ought the thickness of the plate-glass to increase; it must, however, be borne in mind, that the box should not be deeper than is necessary to hold the preparation, otherwise the latter could only be examined with a magnifier of low power.

Method of Mounting Objects in Deep Cells.—For this purpose it will be requisite to be provided with a bottle and glass tubes of the shapes represented by fig. 181 and fig. 182. The bottle is required to contain the spirit or other fluid about to be used for mounting the preparation; it should be of the shape represented by *a*, fig. 181, having a wide mouth, into which is fitted loosely a cork *b*, with a tube *c* passed through its centre; the tube should not touch the bottom of the bottle.

The cell and thin glass cover having been properly cleaned, and the object prepared for mounting, the edges of the former

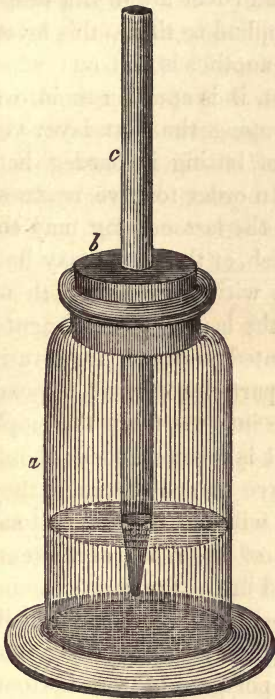

Fig. 181.



Fig. 182.

are now to be anointed with a small quantity of gold-size, the cell is then to be filled with the preservative fluid by means of the tube *c*; if any air bubbles are seen at the bottom of the cell, they should be touched with a sharp pointed instrument, and be conducted by it to the top, where they will burst, and so disappear. The preparation (which we will suppose to be a piece of injected mucous membrane) having been cleaned and soaked for a little time in a similar fluid to that in which it is now about to be mounted, must be placed in the cell, and moved about in the fluid, so that all air bubbles may be got rid of, the thin glass cover is then to be placed on, and all the superfluous fluid either drawn away by the sucking-tube, fig. 182, or by the blotting-paper, as pre-

viously described, the use of the bulb in the tube being to prevent the fluid from rushing suddenly to the mouth. When both the edges of the cell and cover are dry, a thin layer of one of the cements must be applied to them, this layer should be allowed to get hard before another is laid on; when much of the cement is used at first, it is apt to run into the cell, which may be avoided by keeping the first layer very thin, and adopting the precaution of letting it harden before the application of the second. In order to give neatness to the appearance of the mounting, the last coating may consist of black or red sealing-wax varnish, or the edges may be covered with bronze powder, or even with gold leaf, both of which will adhere if applied before the last layer of cement is quite dry. The object to be mounted and the preservative fluid should be kept as free from particles of dust as possible; to prevent the admission of these into the fluid, the employment of the bottle shown by fig. 181 is recommended; should, however, some foreign particles have gained entrance, they, in all probability, after a little time, will sink to the bottom of the bottle, where they will be out of the reach of the end of the tube, if adjusted as represented in the figure.

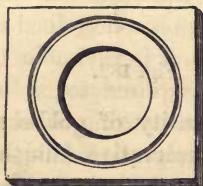

Fig. 183.

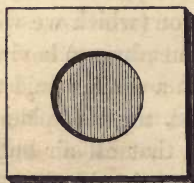

Fig. 184.

To prevent the cement from running into the cell, or the marine-glass from covering more than certain portions of the bottom of the same when fastened to a slide, Mr. Rainey has contrived the following forms. One of these, consisting of a plate of glass about one-eighth of an inch in thickness, and one inch square, with a hole through the centre, is shown by fig. 183; around the hole a channel or groove is made, the object of which, as in Mr. Darker's, shown by fig. 159, is the prevention of the entrance of the cementing material within it. Another form calculated to answer a similar purpose, is shown by fig. 184; in this the hole does not extend through the glass, and the bottom of it may be either

polished or rough; on the under surface of the cell there is a groove as in fig. 183, so that when marine-glue is employed to fasten it to a slide, the glue will be all kept outside the groove, and an object contained in a cell of this kind can, if required, be examined by transmitted light.

Whilst treating of the different forms of cells and boxes for containing large preparations that require the aid of the microscope for their due exhibition, it may be as well here to allude to the method employed by Mr. Dennis, the manufacturer of these boxes for Mr. Goadby and others, to render them better fitted to withstand the expansive power of the fluid they contain; for this purpose he has found it necessary to strengthen the joinings of the sides and ends by what he terms angle-pieces; these are slips of plate-glass, ground into a three-sided prismatic shape, which are cemented to the inside of the box, so as to fill up all the angles made by the sides and bottom, and the ends and sides, and likewise to strengthen the joints on the outside by cementing strips of plate-glass over them, in order to prevent the sides from bursting outwards. Although this is a tedious process, the operator, nevertheless, will be well repaid for his trouble by the greater durability of the work.

The method of cleaning the inside of the box, and the putting on of the cover, is the same as has been described in the smaller cells; to get rid of air bubbles, it is advisable to pour into it much more fluid than is required to fill it, the excess will escape at the sides, and if the pouring be kept up for a few minutes, all the bubbles and foreign bodies in the liquid which may have been washed from the preparation will be removed. The cement employed for the cover by Mr. Goadby was gold-size and lamp-black, but Mr. Dennis adopts the following plan:—In the covers of large boxes he drills a small hole, and fits a cork into it, and places the preparation in the cell with sufficient fluid to cover it, but not enough to reach within half-an-inch of the top. He then cements on the cover with marine-glue by means of a hot iron, and fills up the box with the preservative solution through the hole; by a little shaking all air bubbles can be

got out, the box should now be allowed to remain a few days, and when no more bubbles make their appearance, the cork is put in and cut off level with the top of the cover, and a thin piece of glass is cemented over it to keep it in its place. The whole of the joints of the box are now cemented with marine-glue, and the cover, being fastened on with the glue, is held much more firmly than by any of the other more liquid cements.

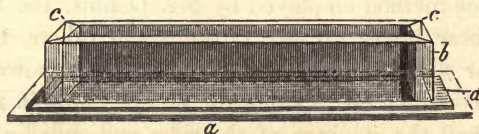

Fig. 185.

A small box *ab* with mitred sides *cc*, and strengthened both with angle pieces in the inside and strips on the outside *d*, is represented by fig. 185; this will be found to be a much more durable kind than that shown by fig. 180. If the preparation to be mounted in one of these boxes be required to be kept in the middle of the box, or if it be necessary that any part of it should be spread out for its better display, the plan adopted by Mr. Goadby is to secure it with fine pieces of silk or China twist; for this purpose he employs loops of strong silk, that are fastened to the bottom or sides of the box either with marine-glue or Canada balsam, to these the fine pieces of silk attached to the preparation may be tied; short loops may be cemented to any part of the inside of the box by means of a piece of glass and a loop, of the size shown in fig. 186. A



Fig. 186.

small quantity of marine-glue placed under the glass when it and the loop have been properly adjusted, can be readily fixed by the application of a hot iron; to make the glass lie more evenly, a groove may be filed in it sufficiently large to contain the end of the loop, and to prevent the silk from being scorched during the operation of cementing, it may be covered by another piece of glass, on which the heated iron should not be placed.

CHAPTER V.

ON CEMENTS.

THE cements employed to fasten down the covers of cells and boxes, for containing microscopical preparations mounted in fluid, are of many kinds, the most useful of them being as follows:—

Japanners' Gold-Size.—This consists of a mixture of boiled linseed-oil, dry red-lead, litharge, copperas, gum animi, and turpentine; the first and last ingredients being its principal constituents, it can be purchased at most shops where varnishes are sold; but as its drying properties increase with its age, it is necessary that it be two or three years old before it is employed. It should be laid on with a camel or sable-hair pencil, and be kept in a wide-mouthed or other vial, closely corked. A thin coating should be laid on at first, and when this is dry, another rather thicker. If the gold-size be very thin, a small quantity of lamp-black or litharge may be mixed with it on a slab by means of a palette knife, and as this mixture very soon dries, it should be used quickly. The brush employed with either of the above cements may be cleaned with turpentine.

Sealing-wax Varnish.—This is made by dissolving sealing-wax of any colour in alcohol, it having previously been broken into small pieces. This cement is not so good as the gold-size, in consequence of not sticking readily to damp surfaces; but it forms an excellent material for giving a shiny coloured coating as a finish to the mounting of an object. It is laid on with a small brush, and should be tightly corked to prevent the spirit from evaporating; the brush may be cleaned with alcohol. Some persons prefer shell-lac to sealing-wax for a cement; but it will be found to be rather too brittle; the method of using and of keeping it is the same as in the case of the sealing-wax.

Asphaltum.—This, which forms a very good cement, is made by dissolving either Egyptian or other asphaltum in boiling

linseed-oil or in turpentine; it answers very well for the first coating, but has not sufficient body, unless mixed with some solid material, to form the entire mass of cement around the covers of objects; it is of a fine black colour, and as such will serve for the last or finishing coating. A solution of this substance in turpentine will make a good cement for fastening cells to the glass slides, instead of the marine-glue or Canada balsam; having this advantage, that spirit may be employed as the preservative fluid without injury to it.

Canada Balsam.—A solution of this substance, either in ether or turpentine, evaporated to such a consistence as is sufficient to allow of its being laid on with a camel's-hair pencil, has been recommended by Dr. J. W. Griffith as a very good substitute for the gold-size; a mixture of lamp-black and white hard varnish, when laid on immediately, he also recommends as a good cement.

Marine-Glue.—This most useful cement, the invention of Mr. Jeffery, is composed of a mixture of shell-lac, caoutchouc, and naphtha; many kinds are made, but that known in commerce as G K 4 is the best for microscopic purposes, a solvent for it is supplied at the manufactory,* and will be found of great service to those who wish to construct any of the larger kinds of cells or boxes. When about to be used, the glue must be cut into thin slices and laid on the glass, and heated until it begins to boil; or a hot iron may be placed on one of the surfaces of the glass until the same effect is produced; if any gritty particles are present, they must be removed. To ensure a firm connection between two surfaces of glass, both must be well warmed, otherwise the glue will stick to one and not to the other. The excess may be removed readily before it is quite cold by means of the chisel described at page 248, and all trace of the remainder by the employment of caustic potash, care being taken that none of the latter be left in contact with the glue, as it is apt to insinuate itself between the two cemented surfaces, and cause their separation in a short space of time.

Electrical Cement.—A very useful cement for some purposes

* Commercial-road, Limehouse.

hereafter to be described, is made by melting together ten ounces of resin, two ounces of bees'-wax, and two ounces of red ochre; to these may be added a teaspoonfull of plaster of Paris; this cement is generally employed for fastening brass or wood to glass, in all kinds of electrical apparatus; it must be used when hot, and can readily be fashioned into any shape before it gets quite cold. Another very excellent but less brittle cement is made by melting together two ounces of black resin, one ounce of bees'-wax, and one ounce of vermilion; this will be useful for making the thin flat cells, as described at page 257, as well as for many other purposes.

Several other cements will be required occasionally by the microscopist, viz., a thick solution of gum arabic in water, to which a small quantity of essential oil has been added, to prevent it from fermenting and becoming sour; also, the same powdered and dissolved in acetic acid or distilled vinegar; as a substitute for these, the liquid sold by Messrs. Ackermann as *diamond cement* will be found of great value, both as a cement and as a fluid for mounting some kinds of objects in. Mastich varnish will also be found useful for cementing opaque objects to discs of cork or leather, or to any of the other kinds of surfaces on which they are intended to be mounted.

White-lead, ground in linseed-oil, will be required for making the cells described at page 256; this should be old but free from all rough particles; it may be mixed up on a slab with a small quantity of gold-size, and if a little litharge be added, it will dry more readily. In all cases where any of the above described cements are used, it should be borne in mind that too much should not be laid on at once, a thin coating at first, and a thicker when the first is dry.

CHAPTER VI.

ON PRESERVATIVE FLUIDS.

THE preservative fluids, like the cements before described, require to be varied according to the nature of the structures they may be employed to conserve; thus, for instance, a solution of salt, alum, and corrosive sublimate in water, that will keep most fleshy substances, will destroy others that contain bone; hence it becomes necessary to select a different fluid for each of these structures, and of all the various kinds that have hitherto been employed, with the single exception of spirit, there is no one kind that is universally applicable; for large preparations proof spirit will answer every purpose; but as this is rather too strong for most of the cements used by the microscopist, it has been ascertained that for all delicate structures there are certain proportions of alcohol and distilled water that will be sufficient to preserve them, and will not act in any way either on the marine-glue, gold-size, or asphaltum. The following fluids will be found the most generally useful.

Spirit and Distilled Water.—In the proportion of one ounce of alcohol 60° above proof, to five of distilled water, a fluid may be made that is capable of preserving not only injections, but the elementary tissues both of animals and vegetables, but all the colours of the latter will be destroyed.

Acetate of Alumina.—This, when dissolved in distilled water in the proportion of one ounce of the former to four of the latter, will preserve even very delicate colours, and when injected into the blood vessels of animals, is said to prevent decomposition, and forms the so called *Gannal process*, employed very much on the Continent for the preservation of animal structures on a large scale.

Goadby's Fluids.—The first of these, and the one for which Mr. Goadby was rewarded by the Society of Arts, consists of four ounces of bay salt, two ounces of alum, four grains of corrosive sublimate, and two quarts of boiling water; these

ingredients are to be well stirred, and the solution very finely filtered. These proportions form a strong fluid, but if necessary a much larger quantity of water may be added without any diminution of its preservative qualities. Another kind consists of three pounds and a half of bay salt, seven grains of corrosive sublimate, and six quarts of water; this fluid, from containing no alum, is not so liable as the former to act on such structures as shell and bone. Another kind, called the *arsenical solution*, is made by mixing together two drachms of arsenious acid, three pounds of bay salt, and six quarts of water; to dissolve the arsenic, it should be boiled with a portion of the water in a tin saucepan. All the above fluids should be carefully filtered before they are used.

Solution of Creosote.—Creosote does not readily mix with water; but if in a very minute state of division, it may be suspended in it: one way of getting a solution is to mix it with water in a retort and distill; the water will come over highly charged with it. Mr. Thwaites, of Bristol, recommends* a fluid into which creosote enters as an ingredient for the purpose of mounting preparations of algæ; it is made as follows:—

Mr. Thwaites' Fluid.—To sixteen parts of distilled water add one part of rectified spirits of wine and a few drops of creosote, sufficient to saturate it; stir in a small quantity of prepared chalk, and then filter: with this fluid mix an equal measure of camphor-water (water saturated with camphor), and, before using, strain off through a fine piece of linen. For the same purpose Mr. Ralfs recommends the following, viz., bay salt and alum of each one grain, to be dissolved in an ounce of distilled water. Mr. Ralfs† also informs us that Mr. Sidebotham employs distilled water alone for mounting delicate specimens of algæ in; and when the last coat of cement is nearly dry, he applies a fine bronze with a camel's-hair pencil.

Glycerine.—This fluid (the sweet principle of fats and oils), lately recommended by Mr. Warington for preserving delicate animal and vegetable tissues, has many advantages over

* Ralfs' *Desmidieæ*, page 40.

† *Op. Cit.*, p. 42.

other fluids, not only in keeping the green colours of infusoria, but, as it evaporates very slowly, it may be employed in cells without so much care being necessary in the cementing of their covers. It is miscible with water in all proportions; the most convenient strength for use will be one part of glycerine to two of distilled water: if made weaker than this, confervæ will readily grow in it when exposed to the air; but not when sealed up in cells. If pure glycerine be employed, it will act on the marine-glue, and from its highly refracting properties, many delicate structures will be entirely lost in it, as in Canada balsam. The best glycerine is procured in the manufacture of lead plaster (the emplastrum plumbi of the Pharmacopœia); it also remains in great abundance after the formation of soap; but in this latter case it always is mixed with some free alkali, which renders it unfit for use.

Chromic Acid is useful for mounting some very delicate preparation; it has been employed by Mr. Bowman and Mr. Brücke to preserve the vitreous humour of the human and other eyes, in order to detect its real structure. Chromic acid may be procured in the crystalline state, and should be dissolved in so much water as will render the tint of the solution a pale straw colour. A much weaker solution than this will keep most animal tissues.

Salt and Water.—A solution made in the proportion of five grains of salt to an ounce of distilled water will answer for keeping very many animal and vegetable structures; it was first recommended by Dr. Cook more than twenty years ago. We are told that Mr. J. T. Cooper,* in the course of a series of experiments to determine the best fluid for preserving coloured tissues, also found that salt and water, to which acetic acid had been added, succeeded extremely well for this purpose; such a mixture will also answer for most minute vegetable tissues. The great objection to the use of all saline fluids is the growth of confervæ which takes place in them; this may, in a great measure, be avoided by the addition of a few drops of creosote, or a small quantity of camphorated water.

* *Microscopical Journal*, vol. i., p. 184.

Naptha.—This, when mixed in the proportion of one part to seven or eight of water, will make a good preservative solution; the author, by accident, having placed in water some portions of skin to macerate, that had been coarsely injected with a material into which naptha entered rather largely as an ingredient, was surprised to find them perfectly free from decomposition even after the lapse of many weeks; the water was impregnated with naptha, and the specimens were in excellent condition, having undergone little or no change.

General Directions.—It may here be stated, that for all large specimens, such as injections, the spirit and water, or Goadby's first solution, may be used; and for others, either the creosote or glycerine solutions, as those containing saline matter, when placed either between glasses simply, or in the thin glass cells, are apt to crystallize slowly, and interfere with the objects that are mounted in them. Goadby's solution, containing both salt, alum, and corrosive sublimate, will keep animal structures that have been injected with size and vermilion exceedingly well; but those in which the vessels are filled with flake-white will have that substance destroyed in a few hours; in these cases either the arsenical or the spirit and water only should be employed. The glycerine fluid, when kept for some time, is apt to become mouldy, it should, therefore, be mixed in small quantities, and then only a few hours before it is required. When objects are to be mounted in either of the above fluids, it must be laid down as a rule that they should have been soaking for some hours in the same fluid, or in a fluid of a similar kind; this should be more particularly attended to when the preparation has to undergo dissection in water previous to its being mounted. It has often happened to the author to find a preparation that had been dissected in water, and mounted in a cell in spirit and water immediately after, completely covered over with small air bubbles in a few hours, from the slow admixture of the two fluids. With Goadby's solution it does not so often happen, but with this a white sediment will be sometimes deposited in the bottom of the cell when the preparation has been soaking in spirit for some time previously. When the

operator has more than one specimen of a rare kind, he should not confine himself to mounting them all in one fluid, but should try such others as in his opinion may be likely to succeed; a note of this should be made at the time on the glass slide, and the date of the mounting also placed thereon; such records will be of great service as guides to future operations.

CHAPTER VII.

METHOD OF MOUNTING OBJECTS IN CANADA BALSAM.

Preliminary Directions.—Before any object is mounted in Canada balsam, it is necessary to see that it is perfectly clean and free from all traces of moisture. Those specimens that are likely to be moist should be carefully dried, or if they be of such a nature that neither water nor spirit will injure them, the best plan is to give them a good wash in water, and then to put them into proof spirit. After this they may be taken out and laid in a proper position for drying, which will take place much more speedily and effectually with the spirit than with water. Other structures that are greasy may be cleaned in the same way by the employment of sulphuric æther; this latter plan is especially applicable to the cleaning of hairs of animals that are to be mounted either in the dry way or in Canada balsam. Entire insects, or parts of the same, may be cleansed by putting them to soak in warm water, and by agitating them in it; by this means most, if not all, of the dust and dirt will be washed off; they may then be placed in spirits of wine, and at any convenient time laid between glasses to dry. A more common plan before mounting them in the balsam, especially if they should be very opaque, is to allow them to soak for a time in turpentine, and as this is perfectly miscible with the balsam, they may be taken from one and put into the other, at the convenience of the operator, without the trouble of drying. The

turpentine renders every part of them more transparent in two ways; in the first by lessening refraction, and in the second by dissolving fluids and substances of a greasy nature and taking their places.

When very thin and transparent objects are required to be mounted in balsam, they become so indistinct, that their true structure cannot be made out, hence some mode of making them dark becomes necessary; this may be effected in two ways, either by charring or dyeing; in the case of vegetable matter, the charring is readily done by placing the specimen between two plates of glass, and holding them over the flame of an argand or spirit lamp until the specimen assumes the proper tinge; it may then be taken out and placed in balsam, and mounted in the usual manner. Some structures, especially those of an animal nature, will not bear the charring process; to these the dyeing only is applicable, and may be effected by soaking them for a time in a decoction of fustic or logwood, after which they may be taken out and dried. A weak tincture of iodine may be employed for the same purpose.

Necessary Apparatus.—The things necessary for mounting preparations in Canada balsam are as follows:—

Some clear and tolerably fluid balsam, the whiter the better; also, some that is older and thicker.

A pair of wooden forceps to hold the glass slides.

A pair of fine-pointed forceps.

A pointed instrument, or, what will answer the purpose, a needle fastened into a wooden handle.

Glass slides, with covers of thin glass of the required size.

A small solar oil or a spirit lamp.

Canada Balsam.—This excellent material was first suggested by Mr. J. T. Cooper, and employed about the year 1832, by Mr. Bond, an ingenious preparer of microscopic objects, the first notice of it in print appears in a small book published by Mr. Pritchard, in 1835, entitled *A List of Two Thousand Microscopic Objects*. The older anatomists were in the habit of using varnishes of different kinds to cover their injected preparations, which, in course of time, became hard

and transparent; the objects belonging to the microscopes described in page 16 are thus coated. Mr. Pritchard* gives the first account of mounting objects in a fluid which subsequently became hard and rendered the mounting permanent; this is said to have led to the employment of Canada balsam for the same purpose. It will be found convenient to have two kinds of balsam, one in a very fluid state, the other much older and thicker; these should be kept in wide-mouthed bottles that can be sufficiently closed to prevent all dust from getting in. The best vessels for the purpose are small glass jars with flat rims, upon which a circular piece of plate-glass may lie perfectly level. The balsam is taken out of these by a small glass rod, which should be of a sufficient length to lie across the inside of the jar obliquely, so as to be covered up with the balsam; the jar should not be more than half full, the rod will then be sufficiently uncovered to allow of its being handled without soiling the fingers, a point that should be particularly attended to.

Wooden Forceps.—For this very useful instrument we are indebted to the ingenuity of Mr. Julius Page; in the upper part of fig. 187 is shown its application to the holding of a slide,

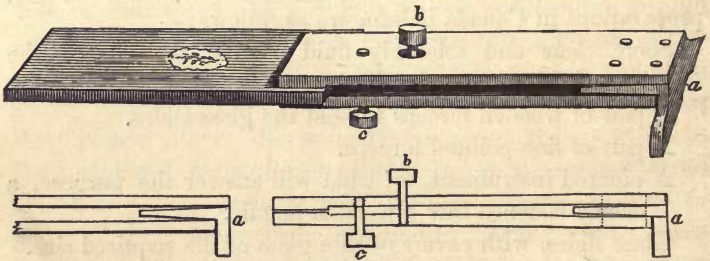

Fig. 187.

whilst in the lower part of the figure is seen a section of it. The entire instrument is composed of wood, with the exception of the end piece *a*, which should be of brass. For holding small slides it should be of the same size and shape as that shown in the figure; but for the larger slides, viz., those three inches long and one inch-and-a-half broad, it should be

* *Microscopic Cabinet*, p. 230.

much stronger; the two flat plates or blades consist of laburnum wood, and are of equal dimensions. *a* represents a piece of brass, bent at right angles; the inner part is wedge-shaped, and the two pieces of laburnum are firmly rivetted to it, and by this wedge the ends of the blades are brought more accurately together. The opposite ends of the blades are cut in the manner shown in the lower figure in order to hold the slide firmly, whilst two wooden studs *b c* serve to separate the blades one from the another. When these studs are pressed, the blades open, and a slide can then be placed between them. The method of using the forceps is as follows:—After a slide has been cleaned and made ready to receive the Canada balsam, it is to be placed in the forceps, and after the balsam has been dropped on, the slide may be warmed over the spirit lamp, and should it now require cooling, the forceps may be placed on the table for the purpose; the piece of brass *a* and the stud *c* form the supports by which the slide is kept perfectly horizontal, and at the same time raised some little distance above the table itself.

Metal Forceps.—For the purpose of handling delicate objects that are to be mounted in balsam, the metal forceps figured at page 119 will be found very convenient, or any of the others presently to be described with the dissecting instruments; in use they are certain to get balsam about their points, this should be cleaned off by allowing the points to soak for a short time in turpentine. No forceps employed for taking up delicate structures should have teeth at their extremities, but should be ground to as fine points as possible, as the teeth are apt to mark the specimens that are held by them.

Needle Point.—For the purpose of destroying air bubbles, or moving about the preparations after they have been placed in the balsam, and for various other uses, a needle fastened into a handle of wood will answer; but an instrument constructed after the plan of that shown in fig. 188 is much better still,

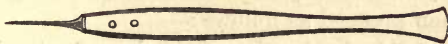

Fig. 188.

This, like the forceps, is certain of being coated with balsam, all of which may be removed either by heat or turpentine. The broad end of the handle will serve for pressing down the glass cover. By this instrument preparations are adjusted to their proper situations in the balsam, air bubbles are drawn away from the neighbourhood of the object; or, if necessary, they may be burst by touching them with the point when slightly warmed.

Spirit or Solar Oil Lamp.—For heating the balsam a small lamp is required; this may be either such a one as is represented by fig. 189 to burn spirit, or one constructed on the solar principle to burn oil.



Fig. 189.

The former is by far the best, as then there is no fear of blackening the balsam, which sometimes happens with oil; but the chance of this is diminished by the employment of a solar lamp, supplied with a glass chimney that extends three inches or more above the flame. In some cases the iron plate described at page 248 for cementing cells will be useful for melting the balsam; but care must be taken in the application of the heat, lest the balsam be made to boil after the specimen is placed in it, especially if it be a portion of a soft animal tissue; if, however, it be some hard structure, that heat will not injure, a little boiling will be of no consequence.

An old knife, with a tolerably flat edge, that may be warmed in the spirit lamp, will be very useful for scraping away superfluous balsam. A small bottle of turpentine and a still smaller quantity of sulphuric ether are also necessary, the former will be in constant requisition.

To Mount Sections of Wood.—These must be well dried before they are put into balsam, especially such as have been cut from green wood; very transparent sections should be charred or dyed brown by one of the methods before described: we must then proceed as follows:—

To Mount Sections of Wood.—These must be well dried before they are put into balsam, especially such as have been cut from green wood; very transparent sections should be charred or dyed brown by one of the methods before described: we must then proceed as follows:—

The glass slide having been wiped perfectly clean with a linen rag or chamois leather, may be taken hold of at one end

by the wooden forceps, and be slightly warmed over the lamp, and a small but sufficient quantity of Canada balsam placed upon it; the glass is to be slowly warmed again, until all trace of air bubbles in the balsam has entirely disappeared; it may now be put aside for a moment or two, and when the balsam is sufficiently cool, the section may be deposited in it, and be adjusted to its proper place by the needle point. If there are no air bubbles, the cover previously warmed on its under surface may be laid upon the balsam and be carefully pressed flat with the end of the handle of the needle-holder, to squeeze out all the superfluous balsam, care being taken to preserve the section, if possible, in the middle of the slide; it will be seen whether, in pressing the cover, the section keeps in its place, or shifts from one side to the other, the pressure must then be so contrived as to keep it in the middle; this may often be managed by moving the cover first to one side then to the other, until the section is brought to the centre of the cover, and the cover to the middle of the slide; when this is accomplished, the slide may be put aside to cool in a horizontal position. But supposing that numbers of air bubbles are present, the balsam must be made to boil; the air bubbles will then be seen to go from the centre to the circumference, where they mostly burst; if not, the slide may be turned over (with the balsam downwards) upon the flame of the lamp, and the heat then being applied directly to them, they will speedily disappear. When the balsam is too fluid for the slide to be turned over and heated, the bubbles may be got rid of by drawing them with a clean needle point away from the centre towards the circumference, that they may be out of the field which the thin glass will cover; the needle point is then to be made warm in the lamp and the bubbles touched with it, when they will burst and disappear as in the former methods.

Should the balsam be too hot when the section is put into it, the latter will probably curl up and numbers of small air bubbles arise; when this is the case, time will be saved if the section be removed and placed either in turpentine or ether, and a fresh slide taken, new balsam put on it, and the process gone over again, instead of using balsam with an

infinity of small bubbles in it. Should the slide on which the balsam has been boiled not be wanted again immediately, it may be placed in a convenient vessel with some turpentine, which will dissolve all the hard balsam, and the slide will be perfectly cleaned and ready for use again in a few days.

Some persons keep their Canada balsam in a tin vessel that can be warmed so as to melt the balsam; a small quantity of this may be taken out when fluid and dropped upon the object previously arranged upon the slide; this plan is attended with little or no risk of air bubbles. The cover should be warmed on its under surface before it is laid on the balsam, and, if necessary, a small amount of heat may be applied to the under side of the slide to make the balsam flow more readily.

Animal Structures.—When animal structures, such as parts of insects or injections, have to be mounted, the heating of the balsam must be carefully managed, and the balsam itself be very fluid to commence with; it should be sufficiently warmed to expel all air bubbles, and, when nearly cold, the object should be placed in it, and covered over in the usual way; if the heat be great, the object is sure to curl up, and bubbles appear in all parts; it will most likely be rendered useless, as no manipulation, however carefully applied, will restore an overheated specimen of animal structure to its former beauty.

It often happens that opaque objects, such as the elytra of beetles, and thick pieces of injection, require to be mounted in one or other of the cells described in page 258; when this is the case, it becomes necessary to use very fluid balsam for the purpose; but not such as has been thinned previously with turpentine, as the author has found by experience that although the cells be carefully covered over, without any trace of air bubbles, these will, nevertheless, appear in a few days; and he has ascertained that they are caused by mixing turpentine with the Canada balsam to make it more fluid; for although they have all the appearance of bubbles of air, that have either gained entrance from without, or have escaped from the preparation itself, they are not really such, but are little vacuities in the balsam, occasioned by the turpentine not freely mixing with it at first, but after a time

doing so; and as the two when united occupy less space than when separate, these little vacuities are the result. Hence it becomes necessary, when objects are mounted in cells with Canada balsam, that the balsam should be new and very fluid, and that before the cover is put on, the balsam should be allowed to remain in the cell with the object for some hours, or even days, if necessary, so that all air bubbles may rise to the surface and burst; when this has taken place, the cover having been warmed on its under surface, may be laid upon the balsam and pressed in the usual manner, in order to exclude all that is superfluous. If the balsam, however, has been thinned with turpentine, the chances are that the vacuities will appear, and to remove them it becomes necessary to take off the cover and fill up the cell with fresh balsam, which may be avoided if attention be paid to the above directions.

In warm weather the vacuities become small, or may even disappear entirely; but when winter approaches they will reappear, and according to the amount of cold, so will the vacuities increase in size.

Fossil Infusoria, &c.—These, together with spicula of sponges and objects of a siliceous nature, which have been dissolved out by acid from a calcareous or other matrix, may be very easily mounted in balsam without air bubbles by pursuing the following plan:—If the objects should be in fluid, a small quantity of the sediment in which they are contained may be taken up by one of the tubes shown at fig. 75, and placed upon a number of slides, and each slide examined by the microscope; those containing good specimens should be laid aside for mounting, whilst the others may be cleaned off. If one of the slides fixed upon for mounting be held over the lamp, the fluid will speedily evaporate and leave the objects behind; whilst this is going on, the needle-point may be used to stir and keep them from collecting together; and so large a space should be made on the glass as not to exceed the size of the thin glass cover; the objects should be all kept as nearly as possible within this space, and not be allowed to get near the outer margin. Should many impurities be present with the infusoria, they will be almost certain to collect

at the margin of the fluid as it evaporates. The cover in these cases should be only so large as to reach nearly to the margin. The ring of impurities may be scraped away after the cover is fixed on, the whole field being then left perfectly clean.

When all the fluid has evaporated, the balsam may be used as follows:—A small drop of it having been placed upon the slide on one side of the spot where the objects are, this is to be heated until all air bubbles have disappeared; the slide is then to be tilted to allow the balsam to run down over the infusoria, the cover previously warmed is to be laid upon it and pressed, and the object finished in the usual manner.

When objects of a cellular nature have to be mounted, if they are such that heat will not much injure, they may be boiled in the balsam, otherwise numbers of air bubbles will be left in the cells, and the true structure cannot then be satisfactorily made out; the extra degree of heat will expand the air, and cause it to make its escape, whilst the balsam will occupy its place. Some objects of a tubular nature, such as the tracheæ of insects, are much better seen if air be contained in the tubes, they will then exhibit the spiral fibre in their interior; but a tracheal tube filled with balsam does not show the fibre at all, in consequence of the balsam having rendered all the parts so transparent. Small insects, such as fleas and parasites of animals generally, when not over heated in the balsam, exhibit remarkably well the ramifications of the tracheæ; but those which have been soaked for a long time in turpentine, or have had the air expelled from the tubes by heat, do not exhibit the spiral markings at all, unless under polarized light, when they again may be rendered visible. These points show the necessity of attending to the management of the heating of the balsam; when air is to be got rid of, the heat must be high, and when the air is necessary to be preserved, the use of turpentine must be avoided, the heat of the balsam must be as low as possible, and the mounting accomplished quickly, in order that the air may not have time to expand very much.

Foraminifera, &c.—Certain chambered shells, of the order

foraminifera, and many of the siliceous loricæ of infusoria, that also have cavities in their interior, are very difficult to mount in balsam, so as to get rid of all the air from their interior, even boiling will not always answer; for this purpose the aid of an air pump or exhausting syringe will be necessary. Mr. Matthew Marshall, who has paid considerable attention to this subject, employs a very strong square copper vessel, provided with a stop-cock; into this boiling water is poured, and it is then placed upon the plate of an air-pump, the slides containing the objects from which the air is to be abstracted are laid upon the copper vessel, the heat of which is sufficient to keep the balsam very fluid; the receiver is then to be placed upon the pump plate and exhausted; air will soon be seen to make its escape in bubbles from the objects and from the balsam, and when again it is admitted into the receiver, the bubbles will disappear, and the balsam will be found to have run into all the cellular parts of the objects, and to occupy the place the air originally did. Should all the air not be got rid of by the first exhaustion of the receiver, the operation may be repeated until the desired effect is produced. The air-pump is also extremely useful for mounting objects on a large scale without air bubbles; several of these being placed between glasses, and secured in their proper places by string or fine wire, may be placed upright in a tin vessel containing balsam liquefied by heat; the vessel (as soon as the objects are adjusted) is to be placed under the receiver and exhausted, the air confined between the glasses, as well as that from all parts of the object, will escape, and the hot balsam will occupy its place. When the balsam has penetrated every part, the slides may be taken out and laid in a horizontal position, and when cold are ready to be cleaned off as follows:—

Cleaning Balsam from the Slides.—For this purpose an old knife, some rags, together with turpentine and a small quantity of ether will be required. If the balsam be very fluid, it may be wiped off with a rag dipped occasionally in turpentine; but if rather hard, the flat-bladed knife, warmed in the spirit-lamp, will readily remove the greater portion, whilst the turpentine rag and a thin sharp knife will clean off the

remainder. Some persons scrape away every particle of balsam from the edges of the cover; the author, however, prefers leaving a little there, which he cuts in a sloping direction, at an angle of about 45° , as he considers that a little embankment of this material tends to secure the cover more firmly to the slide, and to prevent the ingress of air. Objects that have been mounted for some time in balsam should be handled with care, as they are very easily damaged, even in being wiped, and a sudden blow or jar is nearly always attended with a partial separation of the balsam; this is known by the appearance of coloured bands or rings from the thin film of air that has gained entrance between the glasses. When this has happened, heat should be applied both to the cover and slide, and as soon as the balsam is melted, the cover should be firmly pressed down until the rings have entirely disappeared. The risk of this accident will be materially lessened if the slides be coated with paper. Ether is the best solvent of Canada balsam, but the cost of it prevents its frequent use; in some delicate operations, however, it is indispensable.

Other points particularly to be attended to in the mounting of different classes of objects will be alluded to in the part of the work devoted to the description of the mode of preparing them; the rules above laid down will, however, be applicable to by far the greatest majority of objects, and only certain modifications of these will require separate mention.

CHAPTER VIII.

METHOD OF MOUNTING OBJECTS IN THE DRY WAY.

MANY very delicate structures, when placed either in fluid or in Canada balsam, lose several of their most striking characters; these should be mounted dry. Amongst them may be mentioned sections of teeth and bone, and of some kinds of wood, hairs of animals, scales of butterflies, and other insects, all of which may be best examined in this condition. Various

methods have been practised from time to time; one of the oldest, perhaps, was that of enclosing the object between two circular pieces of talc, which fitted into a hole cut out of wood or ivory, and were kept there by a ring of brass wire; four or more of these holes were made in one strip of ivory, and the name given to it was a *slider*; this plan is now only adopted with the inferior microscopes, and has given place to others more generally useful.

First Method.—A thin plate-glass slide having been selected and cleaned, the object is to be laid upon it, and over this is placed a cover of very thin glass, a little larger each way than the object; the plan of securing the cover is as follows:—If a very liquid cement were used, it would immediately run between the glasses and obscure the object; therefore if gold-size be selected, it should be the oldest and toughest. Thick sealing-wax varnish has less tendency to run in, but the best cement of all will be found to be that described at page 269, as being used for electrical purposes; this, when made warm in a ladle, can be laid on with a brush, and afterwards made very smooth with a piece of iron wire heated in the spirit lamp, and when cold can be trimmed off in any way by a knife; as soon as the angle between the cover and slide is filled up, the cover may be more securely fastened down by employing the gold-size or one of the liquid cements; either of these, besides adding to the strength of the first coat, may be employed as the colouring agent, and so improve the appearance of the mounting as well.

Second Method.—Many persons adopt the plan of fixing the cover to the slide by means of paper pasted over both, a small hole is cut out of the centre of the paper for the object to be examined; it has, however, been found in practice that all preparations so mounted are very liable to the growth of *confervæ* about them, occasioned by the moistening of the paper by the employment of paste or other cement. A preparation mounted after the manner of that first described, with cement round the edges of the cover, will look very neat, and be rendered much stronger by the addition of paper, especially such as that employed by Mr. Topping and others for the

purpose; or that of which a specimen is given at the end of a recent publication, entitled *Microscopic Objects*.

Test objects are generally mounted with a very thin glass cover, that is kept on with paper; a much better plan, however, has been lately contrived by Mr. W. S. Gillett, whose skill in these matters is so well known. In mounting the siliceous loricae of *Navicula hippocampus* and *angulata*, the scales of the *podura* and other insects for test objects, he has found it necessary to employ, not only the thinnest kind of glass for covers, but for the bottom plates as well; as it becomes of the greatest importance that the lens employed with the achromatic condenser should be of high power, and be brought, therefore, as near the object as possible, the two best plans adopted by Mr. Gillett may be here described. In the first, two square pieces of the thinnest glass, of unequal size, having been provided, the object is to be placed upon the under surface of the smaller square, which is intended to form the top or cover, a small piece of wax is now to be applied to each corner, and the top may then be laid upon the bottom piece, the wax serving to keep the two glasses together. Two thin pieces of some kind of close grained wood, three inches long, one wide, and about one-tenth thick, as shown at figs. 190 and 191, are also to be provided. Fig. 190 *ab*



Fig. 190.

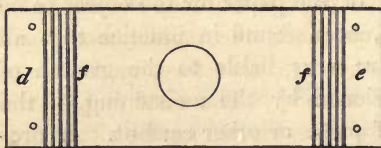

Fig. 191.

represents the outer surface of one of these; in the middle there is an aperture, half-an-inch or more in diameter, whose margin is bevelled off, as shown at *c*. Fig. 191 *de* exhibits the inner surface of the corresponding piece, and at *ff* are seen five cuts made in it with a saw, which do not quite go through the wood;

between these two slices the thin glasses containing the object are placed, and the two pieces of wood are firmly fastened

together by four very short brass screws, the saw cuttings allowing the two opposed surfaces of the wood to be brought into close apposition at the ends; a section of an object so mounted is represented by fig. 192, in which *ab* exhibits the



Fig. 192.

pieces of wood, *c* the squares of thin glass having the object between them, and *ff* the saw cuts which allow the ends of the wood to be brought into close approximation by the screws. The other plan of mounting is shown in fig. 193, *gh*



Fig. 193.

represents a wooden slide similar to that shown by fig. 190, having a hole about half-an-inch in diameter cut out of the middle; the upper surface of this hole is flat, but the under surface is very much bevelled away at *ee*; upon the flat surface the two plates of thin glass, with the object between them, are laid; these are kept in proper position by a layer of paper *ii*, which covers the whole of the upper surface of the wood, and as much of the thin glass as may be required. Mr. Gillett has improved upon the first plan of mounting by introducing between the two plates of wood at each end a strip of metal a very little thicker than the two thin glasses; the saw cuts are present, but the screws are applied between the strips of metal and the thin glass, and not near the ends, as seen in fig. 192. The strips of metal keep the ends of the wood open, and the screws pinch the middle more firmly down on the thin glasses; they are, therefore, more securely fixed than by the former method. The wood employed for the purpose of making these slides should not be either cedar, wainscot, or any other of the kinds that are continually giving off some volatile matter, but should be some close-grained wood that has no smell whatever. In the preceding description it was stated that the thin glasses were kept together by

a little piece of wax at each corner; if necessary, however, Canada balsam may be employed to mount many of the specimens, such as several of the species of *naviculæ* that are used as tests, the balsam having the great advantage of rendering the risk of fracture much less frequent. When thicker objects, such as sections of bone, teeth, or wood, require to be mounted dry, some thin form of cell should be employed; this may be made out of writing-paper, or card-board, by selecting a piece of the same size as the cover about to be employed, and cutting out a hole in it of the shape required, and cementing this to a slide by sealing-wax varnish; when the spirit has evaporated and the cell is firmly fixed to the glass, a coating of the same cement may be employed to cover the entire upper surface of the cell, and to thoroughly saturate the paper. When this coating is dry, the cell is fit for use; the object being laid in it, the thin glass cover may be put on by first touching the edges of the cell with some very thick sealing-wax cement, and then dropping the cover on it; the cover will be held in its place by the varnish, and the slide should now be put away until the varnish is dry, when another small quantity of the same material is to be applied round the edges of the cover, but not enough to run far under it; as soon as the last coat is dried, then another may be laid on until the cover is firmly fixed. Cells may also be made of the electrical cement, described at page 269, for the reception of thin objects, by painting it on the slide in the shape required. The object being placed within a cell so formed, may be fixed down by making the edges of the cover sufficiently hot in a spirit lamp to melt the cement when it is laid upon it. Should this be ineffectually performed, a small heated wire applied to the glass or to the cement will readily accomplish it. If such a cell as this does not look neat, the slide may be covered with paper, with a hole in it sufficiently small to hide all appearance of the cement. Gutta percha rolled out into sheets, and cut out with a knife or with punches of the required size, may also be employed as a substitute for the paper; but it is difficult to make it stick to glass unless some solvent of it be used as the cement. Even the small elastic

bands made of vulcanized India-rubber will answer for thicker objects, or the glass rings or cells that have previously been described to contain objects mounted in fluid, will all do equally well for such as require to be mounted dry.

Mr. Darker's Method.—Objects, such as sections of wood, that do not require a high power for their examination, may be mounted in a very neat way after an excellent plan first practised by Mr. Darker. The following description, abridged slightly from that given in a recent work, entitled *Microscopic Objects*, will convey a good idea of the method to be adopted for this purpose:—“Two slides of equal size being selected, the edges of each should be bevelled off on the metal plate, as represented by fig. 194, so that when they are put



Fig. 194.

together, a groove or channel is formed, as shown at *b* in the figure. The surfaces having been cleaned, the bevelled parts are to be coated with a thin layer of sealing-wax varnish; when this is dry, a label, if required, may be gummed to the bottom slide, and then the objects may also be laid on it; if it be necessary to keep them in place, the smallest possible quantity of gum may be applied to one corner; the top plate is now to be laid on the specimens, one of the edges is then to be heated in the flame of a spirit lamp, and the groove filled with sealing-wax, as shown at *a*; when one edge is done, the others are to be heated in the same manner, until the entire groove is filled with the wax, which thus acts two purposes, one to keep the slides together, and the other to prevent the access of air. The excess of wax may be cleaned off from the edges by rubbing them upon sand-paper laid on a flat board, until they are smooth; if bright edges be required, they may be passed quickly through the flame of the spirit lamp. It must, of course, be borne in mind that all objects mounted in this way should be made perfectly

dry before they are sealed up. The author, some years ago, was presented with a collection of sections of wood by Mr. Darker, which have not only kept in their places, but are as perfect and as free from conferva as when they were first received. They are all labelled after a very excellent plan, viz., by having the generic and specific name on one side of the label, and the popular on the other.

CHAPTER IX.

MOUNTING OPAQUE OBJECTS.

OPAQUE objects may be mounted in various ways:—on discs, on cylinders, on glass slides, or in cells.

On Discs.—The discs consist of circular pieces of some soft material, through which a pin is passed; they may vary in diameter from a quarter to one inch; one kind may be conveniently made by glueing together two pieces of card-board, with a piece of rather thick chamois leather between them, and then cutting out with a punch discs of any required size. Through the chamois leather a long but strong pin is to be passed in the direction shown by fig. 195; the discs may be made black with lamp-black (that sold in shops in the moist state in little oblong saucers will be found the best); or with lacker in which lamp-black has been mixed; in this latter case they should be warmed either before the lacker is applied or afterwards, to dry it. The felt which is used as gun-wadding, or the pellets that are sold already cut out for guns, may be substituted for the card-board and chamois leather, or even leather itself may be used with advantage.



Fig. 195. Transverse slices of small phial corks are very good, but to make them look well, they should have their cut surfaces covered with black paper, which renders their manufacture rather more troublesome.

Upon these discs the objects are to be cemented ; this may be readily done either with some thick lamp-black or with the lacker and lamp-black, both these cements having the advantage of being of a dull black, and not of a shiny aspect as gum or as sealing-wax dissolved in spirits of wine, which, on this account, are objectionable, the darker an object is, the more dark ought the disc to be ; white discs should be avoided, as they reflect the light and interfere with correct definition. Objects may be placed upon

both sides of the discs, or one side may be occupied by a number for the sake of reference, and this side may be either left white or black ; if black, the number may be put on in white, or a printed one with a white margin may be used. Five different ways of mounting objects on these discs are shown by figs. 195-6-7 ; in the first, where

the objects are thick, they may be simply cemented to the disc ; in the second is seen a plan which answers very well for the capsules of mosses, viz., to glue a small piece of cork to the lower surface of the disc, and to attach the little stems of the capsules to this, they can then be arranged in the best way for viewing their mouths ; in the third and fourth way the same thing is shown, but a small circle of cork is employed instead of a larger piece. And in the fifth is exhibited the method of mounting, so that the side of the object as well as the front may be examined.

When it is necessary that both sides of an object should be viewed, a disc, an inch or more in diameter, may be used, out of which a small disc has been punched, as shown by

fig. 198, but not exactly in the centre ; through the broad part the pin is passed, and the object may be cemented to one of the sides, or what is better, if it can be managed, is to separate, by means of a penknife, the chamois leather from



Fig. 196.

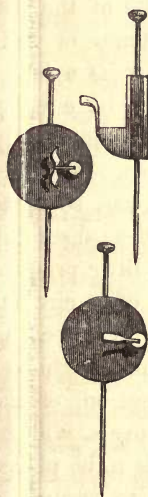

Fig. 197.

one of the cards, and into this fissure to place the object, the application of a little cement being required to keep it there. Supposing the object to be a portion of fern, this plan will enable an observer to view both sides of it, or even look through it, and if at any time the disc were laid flat on the



Fig. 198.

table, the object would be preserved from injury by being situated in a plane intermediate between the two outer sides. Supposing very small discs are required, Mr. George Jackson has devised an excellent method, whereby with pins and black sealing-wax some useful ones may be made in the following way:—Take a long pin and slightly warm it in the middle, then take a stick of black sealing-wax and melt it in the flame of a candle or spirit lamp; having put a small quantity upon the middle of the pin, hold the latter either in the flame of the lamp or near it, and as the wax melts revolve the pin on its axis; if this be done rather quickly, the sealing-wax will be equally distributed about the pin, the pin then should be immediately removed from the flame, and be placed upon a piece of glass, and the wax pressed upon by another piece of glass, so as to convert the globule into a flat disc. Upon these discs the objects may be mounted in the usual way. A little practice will enable a person to make them easily, and of a circular figure; they may be also made of an oval shape by spreading out the wax on the pin, and being careful that the thicker part of it occupies the centre of the pin, and not one of the ends, otherwise irregular shapes, and not true ovals, will be the result. The ground upon which the object is to be placed is necessarily shiny, but it can easily be made to assume a dead black hue by scraping it with a knife. Discs so made are very durable, and have a neat appearance.

On Cylinders.—These may be made of cork, wax, or ivory, of the shape represented by fig. 199; the pin may be passed either through the long or the short axis of the cylinder; so that an object may be mounted on the ends of the latter, or

on the side of the former. Gutta percha, which is now coming into use for lathe bands, and may be obtained of nearly any size, can be cut into lengths of half-an-inch or more, and a pin heated to a temperature a little above that of boiling water may be readily passed through them, and when cold will be fixed very tightly.

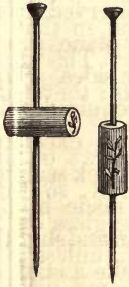

Fig. 199.

On Slides.—This is most easily done by punching out from black paper little circles from the one-fourth to one inch in diameter; these may be stuck either with gum or paste upon the ordinary sized glass slide, as shown by fig. 200; upon these black discs the objects may be fixed with any of the cements before alluded to, and in the same manner as on those of card-board or leather. They possess this great

advantage, that they may be arranged in a cabinet with other objects, which cannot be done with those on the pins; but



Fig. 200.

they are very liable to be injured materially by dust and dirt, and only small shells or objects that cannot be damaged by wiping with a camel's-hair pencil, ought to be mounted in this way.

In Cells.—For this purpose it will be found convenient to use cells not exceeding half-an-inch in diameter, or the size of the largest dark stop; they may be cut from large barometer tubes of any required thickness, and are to be cemented to the slides with marine-glué in the usual manner. After the cell has been cleaned and the cover and object selected, some black sealing-wax varnish, rather thick, may be dropped into the bottom of the cell; upon this the object may be laid, the varnish will serve a two-fold purpose; first, as a cement to keep the object in its place, and, secondly, as a stop to prevent the transmission of light. When the sealing-wax has become hard, the cover may be laid on; this can be effected in one of

two ways, either by the plan recommended for the thin dry cells, or by putting a layer of old gold-size upon the walls of the cell, and allowing it to get nearly dry, then laying on the cover, and after the lapse of a day or two, when the size has become hard, filling up the angle between the cover and cell with gold-size laid on in several thin coatings, so that it may not run in and interfere with the object. This plan will be found highly advantageous for most objects; they may be well seen with the Lieberkuhn; the black cement acts as a stop or dark well, and the small size of the cell allows of the light being readily transmitted on all sides of it, so that no stop under the stage will be required. The glass cover does not at all interfere with correct definition, unless the light be thrown upon it very obliquely, when some pencils must necessarily be reflected; but with the vertical light from the Lieberkuhn, nearly as much will pass through as if the cover were not present. The elytra of the diamond and other beetles which still exhibit their rainbow hues when placed in Canada balsam, can be well seen when mounted in this manner; but those objects which require the light to fall upon them at very oblique angles to show their play of colours, must be mounted on discs with the pin, by which means they can with facility be turned in every direction and, so display their resplendent tints.

When Canada balsam is used for mounting the specimens, the precautions mentioned in page 280 must be attended to; the balsam must be very fluid, but not made so with turpentine, and the cover must not be put on until all the air bubbles have disappeared, otherwise the little vacuities there alluded to will occur after the lapse of a few weeks or months.

A very convenient mode of mounting opaque objects in

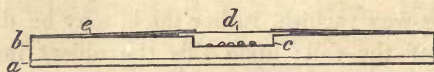

Fig. 201.

cells is shown in section by fig. 201, where *a* represents an ordinary glass slide, to which is attached a thin piece of maho-

gany *b*, having a cell *c* bored out in its middle by means of a centre-bit; the hole should not extend through the entire thickness of the wood, but about half way, as shown at *c*; the objects fastened to a disc of paper or card may be secured to the bottom of the cell by means of one or other of the cements previously described, and a cover of thin glass *d* having been placed over the hole, may be firmly fixed there by one of the cements or by a layer of paper *e*, gummed to it and the mahogany in the manner described at page 285.

Mr. Julius Page has made some very excellent cells of the flattened tin wire employed by cabinet-makers for inlaying, by bending it into a square or round shape upon a bar or cylinder of wood; these he fixes to the slide by marine-glue or other cement, using a large quantity on the outside of the cell to form an embankment, and to prevent the gold-size employed in the fastening down of the cover from entering the cell where the two ends of the wire are brought into contact. Cells so made will answer as well for preparations mounted in fluid as for those that are dry, tin being a metal on which few of the preservative solutions will act.

In Pill Boxes.—The author's late brother, Mr. Edwin Quekett, adopted a plan for mounting opaque objects, which answered exceedingly well; this was to select some small but well made pill boxes, and to glue to the bottom, or to the side or cover, a piece of cork, of one or other of the shapes repre-

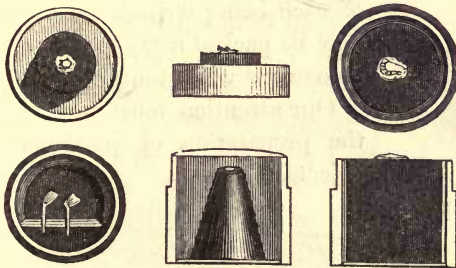

Fig. 202.

sented by fig. 202. In the first three are seen cylindrical pieces glued to the cover, in the fourth is shown a semicircular

piece fixed to the side, and in the fifth and sixth a cone and a cylinder attached to the bottom of the box, all of which plans will be found useful for different kinds of objects.

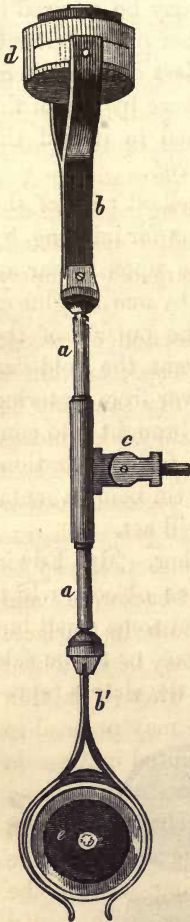

Fig. 203.

In order to hold these boxes, he employed a pair of forceps of the shape represented by fig. 203. *a* is a piece of steel wire, having at each end two pieces of main spring *b b'*, those at *b* have two semicircular pieces of brass rivetted to them to embrace the box as shown at *d*, whilst at *b'* the springs are bent as there represented, in order to hold the cover or the bottom of the box in a horizontal position. The wire *a* slides through a short piece of spring tube attached to a joint *c*, below which is a pin for connecting the instrument to the stage of the microscope, as in the case of the other forceps described at page 113. Mr. Jackson has also adopted the plan of mounting opaque objects in pill boxes; but he makes a hole in the bottom of each, by means of which he fits them on a sharp-pointed pin attached to the ordinary forceps. Objects so mounted possess many advantages: they are preserved from dust and injury, and the names of each being written on the cover, they may be packed away in drawers and easily recognised when required.

Our attention must now be directed to the preparation of particular classes of objects.

CHAPTER X.

TO MAKE SECTIONS OF BONE AND TEETH.

THE apparatus required to make sections of bone and teeth will be as follows:—A fine saw, such as is used for cutting metal; two or three flat, safe-edged files, one of them very finely cut; a small hand-vice; two hones of the water of Ayr stone; strips of glass, two-inches-and-a-half long, and half-an-inch broad; some old Canada balsam; a small bottle of sulphuric ether; and a strop of buff leather, charged with putty powder.

The first thing to attend to in making a section of recent bone, is to select a part perfectly free from grease; as thin a section as possible is to be cut from it by the fine saw, and be made flat, and at the same time further reduced by means of the file. If the section be not very brittle, it may be held by the hand-vice, and being rested upon a flat piece of wood or cork, may be brought by the file nearly to its proper degree of thinness. If one hone only is at hand, the section may be laid upon it with some water, and be rubbed backwards and forwards by a finger pressed upon it, until both its surfaces have acquired a certain amount of polish; it may be examined from time to time by the microscope to see when it is thin enough, and when this point is arrived at, we may proceed to polish it; if the section is intended to be mounted in Canada balsam, a great amount of polish is not necessary; it may then be simply rubbed upon a strop of buff or chamois leather, until the desired effect is obtained; if, on the contrary, the section is to be mounted dry, the polishing should be carefully attended to, a buff leather strop, with putty powder and water, must be employed, and the section rubbed upon it until a perfect polish is procured. The excess of putty powder about the specimen may be removed by repeated washing. If the operator be provided with two hones, the section may be quickly made very thin by rubbing them one upon the other with the section between them; when

sufficiently thin, it may be polished in the above described manner. Should, however, the section be brittle, we must have recourse to a different method, to effect its being ground on the hone without fracture. For this purpose, as thin a section as possible having been removed by the saw, it is first to be filed and then rubbed down on the hone, and be polished on one side only. The section is next to be dried, and then cemented to one of the narrow strips of plate-glass with Canada balsam; in order to effect this, some old balsam should be procured, and a small portion laid upon the centre of one of the flat surfaces of a strip of plate-glass, which is then to be heated until the balsam is melted and many of the air bubbles have disappeared; the glass may then be removed from the flame, and when it has become slightly cool, the section, with its polished surface downwards, is to be placed upon the balsam, and pressed firmly down until the balsam is quite cold, care being taken that the entire surface of the section be in contact with the glass. A good deal of the superfluous balsam may now be cut away from the sides of the section, sufficient being left to hold it firmly to the glass; if it be very thick, the file may be used to reduce it at first, and then it may be brought down to a proper degree of thinness by the hone; as the grinding is being proceeded with, the section may be from time to time examined by the microscope, and when it has been found to be thin enough, this surface also may be polished on the buff leather in the same way as the one first described. The next step is the removal of the section from the glass; this is readily effected by dropping the slip of glass into the stoppered bottle containing ether, which, in a very short space of time, will dissolve all the balsam, when the section will drop off; it may then be removed from the ether, and when dried is ready for being permanently mounted. It will now be seen why a slip of glass of a particular length and breadth was recommended in the onset, it has many advantages over either longer or shorter strips; in the first place, if the section should be thicker on one side than the other, the glass can be tilted a little, so that the side which is the thickest may be rubbed the most, and in a short time an

uniform degree of thinness will be obtained; secondly, it is by far the best plan to keep ether in a bottle with a stopper not much exceeding half-an-inch in diameter, as in larger bottles the stoppers seldom fit so nicely as to prevent evaporation; into the small bottles the slips of glass previously described will readily drop, and the ether need not more than half fill the bottle, for so long as it reaches as high as the section, the desired object will be obtained; when, however, the stock is reduced so low that it will not reach the section, one end of the slip of glass may be cut off with a diamond, and only a small quantity of ether will then be necessary.

If it be required to make sections of fossil bones that are far too hard to be cut with a saw, the apparatus employed by the lapidary must be had recourse to; this consists of a thin iron wheel, the edge of which is charged with emery, or with diamond dust; after the section has been cut, it is then to be cemented to a piece of glass and polished on both surfaces, the material used for the cutting being a fluid known as oil of brick. The ordinary wheel employed by the lapidary runs horizontally, and is turned by the hand; an apparatus of the same kind, but used by the jeweller, consists of a small steel or copper disc, turned by a foot-wheel; one or both of these will be required by those who wish to devote much attention to the structure of fossil bones and teeth. It is usual to mount such sections on pieces of plate-glass, without any covering of Canada balsam or thin glass over them; if they have a polished surface, their structure can be admirably made out.

When it is necessary to examine the bone cells of fragments of fossil bone, small chippings only are required; these may be procured by striking the bone with the edge of a small hammer, then carefully selecting the thinnest of the chips, and placing them at once without any grinding in Canada balsam.

Mounting Sections of Bone.—The next process is that of mounting the sections; this may be done either in the dry way, as described in page 288, in a thin cell in fluid, or in Canada balsam. If the section is very thin and transparent, and well polished, it ought to be mounted either in fluid or

dry ; if not, then the Canada balsam may be had recourse to. The method of doing which is as follows:—After having placed some thin Canada balsam on a slide of the required size, it must be heated until it boils; it may then be laid aside for a moment to cool, when the section, having been previously made dry, is to be placed in it; if the balsam is too cold for the section to sink into it, a little more heat must be applied, and as soon as the balsam is again fluid enough, the section may be embedded in it; should the heat be such as to cause air bubbles to appear, it will then be desirable to remove them before the thin glass cover is laid on; this may be done in two ways, either by drawing them from the field in the neighbourhood of the object with the pointed instrument, or by heating the balsam again, so as to make it boil; when the bubbles are all removed, the thin glass cover, with its under surface warmed, may be laid upon the balsam, and pressed down so as to exclude at the same time all the air bubbles and all the superfluous balsam. In some cases the author has found that sections of bone, which have been laid in balsam and heated until the balsam has boiled, exhibit their intimate structure more beautifully than they did before the extra heat had been applied. When a section is put into very liquid balsam, the bone cells very soon become filled, which makes the structure indistinct; hence it is better to mount all bones in the dry way or in fluid, except those which are of a very dark colour, and have their bone cells and canals filled with earthy matter. All sections of recent and greasy bones should be soaked in ether for some little time before they are mounted; this dissolves the grease, and makes the bone cells and their canaliculi much more distinct.

Fragments or chippings of fossil bones may be put into balsam without any grinding; and as it generally happens that in such bones all the cells and canals are full of earthy matter, it does not matter if the balsam have been made to boil; it is, perhaps, the better plan that this should be done, as it makes the intercellular tissue more transparent, and the bone cells, therefore, can be seen more distinctly.

It may be as well here to state, that the sections should, if possible, be made in two or more directions; thus, for instance, if the specimen about to be examined be a portion of the shaft of a long bone, we should cut the first transversely and the other two longitudinally; one of the latter may extend through the medullary cavity, and the other merely through the outer or periosteal surface. The scales and thin plates of bone of fishes will rarely require more than grinding down on the hone; if the surface of the scale be enamelled, as in the *Lepidosteus*, the inner surface only may be rubbed down on the hone, and the outer left with its natural polish of enamel on it, the ground surface may be cemented to a slide by Canada balsam, and the enamelled will then require no covering either of thin glass or of balsam, but be kept in the same manner as the fossil woods before described. In order to obtain a perfect notion of the structure of bone, one or more sections should be soaked in dilute muriatic acid to get rid of the earthy matter, and others in caustic potash to destroy the animal matter; these should be mounted in fluid, and will be found very instructive.

To make Sections of Teeth.—The teeth of fishes not being supplied with a layer of dense enamel, may be cut in the same way as ordinary bone with a fine saw, and then be rubbed down between the hones, and polished in the usual manner; but those of nearly all the higher mammalia being coated more or less with enamel of flinty hardness, will require a much greater amount of labour to be expended on them.

The saw best adapted for cutting through the enamel is that used for iron and brass; even this will often become blunt before the cutting is completed. It will be almost in vain to indulge in the hope of making more than two longitudinal sections of one tooth, this can only be effected by cutting it down through the middle, and after cementing the cut surfaces to a plate of glass, to reduce them to the proper degree of thinness by the file, and finish them on the hones. The lapidary's wheel will be found much more useful for teeth than for bone, as a wheel charged with diamond dust will speedily cut through a thick layer of the hardest enamel.

The operation of laying sections of teeth in the thick balsam should be carefully performed, as the enamel very readily separates from the dentine or ivory; the grinding and polishing should also be carried on with care to prevent the separation. The sections, like those of bone, should be made in two directions, one transverse and the other longitudinal, and if the structure of the enamel require to be examined, an oblique section will be found very instructive, although very difficult to make.

To Mount Sections of Teeth.—These may be mounted in the same way as the sections of bone; an examination by the microscope will serve to determine whether any particular specimen should be placed either in fluid or balsam, or be preserved dry; the latter plan will, however, be found on the whole to be the most satisfactory, but in this case the section should be well polished. Dark coloured fossil teeth will be well exhibited in balsam, and may even be boiled in it if necessary, as the tubes of the dentine are in most cases filled with earthy matter.

CHAPTER XI.

TO MAKE SECTIONS OF SHELL AND OTHER HARD TISSUES.

FOR this purpose nearly all the apparatus described for making sections of bone and teeth will be required. By far the most important instruments, however, will be found to be the file and the hone. Shell, although generally much softer than bone or tooth, is, nevertheless, very brittle, and thin sections require to be handled with very great care. The best plan of proceeding is to make a portion flat on one surface, and polish it first on the hone and then with putty powder, and to cement this surface to the slide on which the section is intended to be mounted by means of Canada balsam,

the file may then be employed to reduce its thickness, and the hone to finish it; the section should be examined from time to time by the microscope, to see when it is thin enough, and, if required, the slide may be placed either in ether or turpentine to dissolve away the old balsam without separating it from the slide; but should the specimen be very brittle, it should be allowed to remain on the slide on which it was ground, and after having been made as clean as possible, some new balsam may be dropped upon it, and a cover of thin glass laid over it in the usual way; but if the section be sufficiently strong, it may be removed by ether from the slide, and be mounted in balsam as a fresh object; the latter plan will be found the neatest and best, provided it can be accomplished without injury to the specimen. When it is required to investigate the arrangement of the animal matter in any section, it should be subjected to the action of dilute muriatic acid; this is termed by Dr. Carpenter the *decalcifying process*; such specimens, after soaking in water to get rid of the acid, may be mounted with fluid in the thin glass cell. The structure of many shells of the oyster kind can be very well made out by selecting some of the thinnest of the flakes or laminæ found near the outer margin of the valves of the shell; these, after having been washed and dried, may be mounted in Canada balsam in the usual manner. Some shells, also, of the genus *Pinna*, that exhibit a prismatic structure, will separate readily into prisms; these may also be mounted either in fluid or in balsam without any further preparation. The most difficult shells to cut are those whose structure is *nacreous* or pearly—the ear shell, *Halotis*, is the best example of this kind; these, however, will yield to the file and hone; sections of them should be decalcified, and it will then be seen (as was discovered by Dr. Carpenter) that the splendid hues which this tribe of shells presents are due to the plication of the animal membrane. Amongst the shelly tissues may be mentioned the spines of the Echinodermata, the tegument of the Crustacea, and the bone of the Cuttle fish. All these may be prepared in the same manner as shells, by the file and the hone, with the exception of the last, which may be cut

sufficiently thin with a very sharp knife. The spines of the Echini, after having been cut transversely with a saw, and then ground down and polished, form some of the most beautiful objects for a microscope of low power; considerable difficulty will, however, be found in getting a section perfect and at the same time very thin. A portion of the shell of a crab, taken from one of the large claws, also forms a most interesting object; but the author would refer those who wish to obtain a knowledge of these beautiful structures to the very valuable papers of Dr. Carpenter in the *Reports of the British Association for the Advancement of Science*, where he will also find accurate representations of the most remarkable kinds.

To make Sections of hard Vegetable Tissues.—The dense structures which compose the stones of some of the pulpy fruits, such as the peach, apricot, plum, and cherry, are beautiful objects for microscopic investigation; they resemble in a very striking manner the osseous tissues of animals, and like them require to be cut into thin slices, in order to exhibit their true characters. The principal instruments required for this purpose will be the saw, the file, and the hone; those stones that are tough, such as the cherry and plum, can be easily made thin; others that are more brittle will demand some care in their preparation, whilst some few, as, for instance, the ivory nut, are so hard, as even to require the aid of the cutting-machine or the lapidary's wheel for their reduction to a proper degree of thinness. The method generally employed to make sections of these hard tissues for the microscope is very similar to that of bone before described, viz., to cut as thin a slice as possible with the saw, then to reduce this nearly to the requisite thinness by the file, and finish it with the hones; as all these tissues are more or less of a dark colour, they will be best displayed in balsam, therefore the process of polishing on the buff leather with putty powder may be dispensed with. The development of some of the hard tissues may be very well seen in the scales of the cone of firs; these may be readily cut in the machine employed to make sections of wood presently to be described, and may be

mounted in balsam in the usual manner. Another form of hard tissue may be procured by maceration from the pear tribe; this is known to botanists as *gritty tissue*, and should be mounted in fluid, as the balsam makes it too transparent.

To prepare Siliceous Skeletons of Vegetables.—In all plants known as grasses, silica or flint is more or less abundant; its presence may be recognised in many ways, but heat and nitric acid are the agents generally employed to separate it from the other less durable substances with which it is intimately connected. Silica forms a coating to the stems of grasses; it is even found in small masses or concretions in the stems of the bamboo, and is then known by the name of *tabasheer*. The attention of microscopists was first directed to the siliceous skeletons of certain parts of grasses by the Rev. J. B. Reade, in the year 1835; the specimens first examined by him consisted of the husks and parts of the stem of the wheat and oat; they were prepared by subjecting these parts to a very high temperature in a platinum crucible, whereby all the carbonaceous matter was burnt off, and an ash of silica was left; this was removed and mounted in Canada balsam, when a perfect cast even of the most minute vegetable structure in flint was found on microscopical examination. One of the most beautiful specimens for exhibiting the arrangement of silica in its stem is an *Equisetum*, sold in the oil and colour shops under the name of the *Dutch rush*; it is used by the cabinet-makers as a substitute for sand or glass paper, for rubbing down the inequalities in the surface of wood; this is best prepared by cutting the stems into short pieces, and boiling them in strong nitric acid in a tall vessel; copious fumes of gas will be given off as the carbon is being removed, the vessel should then be laid aside for a time, and more acid added when the effervescence has ceased; if the specimen be not immediately wanted, it may be kept in the acid until the perfect removal of all the other constituents has been effected. A portion of this plant, when well prepared, should be perfectly free from all foreign matter, and after being thoroughly washed, may be mounted either in fluid, in balsam, or even dry. In balsam it forms a beautiful object for polarized

light; but in fluid, its true nature is best exhibited. The *paleæ* or *bracts* of a grass, known as the *Festuca pratensis*, exhibit a beautiful arrangement of silica without any preparation by acid; they can be shown dry as opaque objects, and for the purpose may be cemented to one of the discs described at page 290; or, if preferred, may be mounted in fluid, and then examined by transmitted light. But the *paleæ* of the wheat and oat, which are known as *chaff*, from being more opaque and less abounding in silica, will require either the aid of acid or of heat to exhibit the arrangement of it in them.

CHAPTER XII.

ON MAKING SECTIONS OF WOOD.

FOR this purpose we must be provided with an instrument termed the *Cutting machine*, which consists of a plate of metal, on which a knife or razor is made to slide, and the wood to be cut is firmly wedged into a triangular or other tube, and is raised above the surface of the tube by a very fine screw, as high as the thickness of the section required. The first instrument of this kind was invented by Adams, about the year 1770, and was subsequently improved by Mr. Cumming; it is described and figured in the microscopical essays of the younger Adams, and is of the same kind as that employed by Mr. Custance, "who was unrivalled," says Adams, "in his dexterity in preparing and accuracy in cutting thin transverse sections of wood." In subsequent times other instruments have been contrived for the same purpose, some provided with knives that moved circularly, others with knives fixed in a strong frame-work of metal, whilst, in not a few, the cutting was performed by a razor of the ordinary kind, or one ground perfectly flat on one side. A very excellent machine for this purpose, which the author has been in the habit of using for many years, and can, therefore, strongly recommend, is shown

in fig. 204; it consists of a block of Spanish mahogany, into which are fastened four strong brass pillars that support a flat table of the same metal, eight inches long, three wide, and

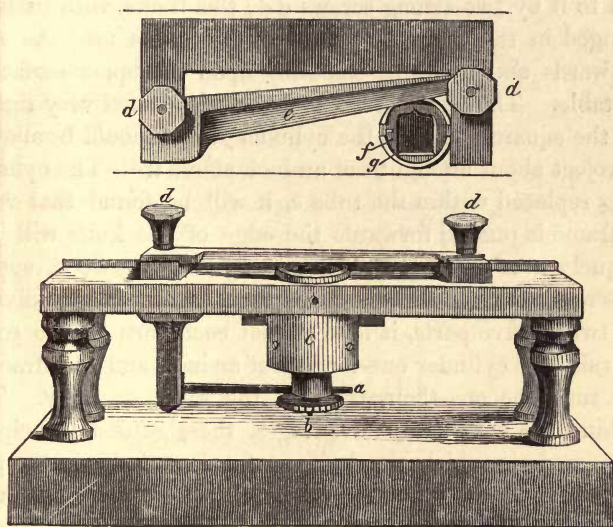

Fig. 204.

three-tenths of an inch thick, having a raised edge screwed to one of its sides; to the under surface of the middle of this table, and nearly close to the opposite side to that having the raised edge, is screwed a stout tubular piece of brass *c*, which passes through the table and projects about a quarter of an inch above its upper surface; into this tube is fitted accurately a cylindrical piece of brass *f*, having a hole *g* about five-eighths of an inch square, extending throughout its entire length. This cylinder is capable of being raised by a screw with forty threads in the inch, the head of which *b* is divided into twenty-five parts; the divisions are cut so deep, that a thin wedge-shaped piece of steel may be pressed firmly into any of them by the spring *a* with which it is connected; this contrivance answers two purposes, one as a micrometer for determining how high the cylinder must be raised to cut the finest section, and the other for preventing the screw from being moved.

A strong brass frame, of the shape shown in the upper part of the figure, and of nearly the same thickness as the table, has a knife *e*, ground perfectly flat on its under surface, firmly fixed to it by two strong screws *dd*; this frame, with its knife arranged in the manner seen in the figure, is made to slide backwards and forwards smoothly upon the upper surface of the table. The wood about to be cut is driven very tightly into the square hole *g* in the cylinder *f*, and should be allowed to project about an eighth of an inch above it. The cylinder being replaced within the tube *c*, it will be found that when the frame is pushed forwards the edge of the knife will pass obliquely over every part of the surface of the wood, and as the screw has forty threads in the inch, and its head is divided into twenty-five parts, it follows that each turn of the screw will raise the cylinder one-fortieth of an inch, and each fraction of a turn the one-thousandth of the same quantity. This machine has very many advantages, these consist principally in the mode in which the knife is fixed, and also in the plan of the wood about to be cut being firmly supported on all sides by metal, but in such a manner as to keep the latter without the reach of the knife, the screw being so short as not to be able to raise the cylinder quite as high as its edge. In most machines of this kind the knife rubs upon the brass, by which the cutting edge is liable to injury, and the wood is not driven tightly into a cylinder, but is raised out of it by the screw, consequently it cannot be kept so firmly against the cutting edge, which will be found very inconvenient when hair and such other soft structures require to be securely wedged up before sections of them can be made.

Mr. Topping has contrived a very convenient and useful form of cutting-machine on a plan represented in section in fig. 205.* A B is a flat piece of mahogany, seven inches long, and four wide, to the under surface of which is attached, at right angles, a piece G, of the same size as A B. D represents a flat plate of brass, four inches long, and three wide, screwed to the upper surface of A B; to the middle of this plate is

* This machine, together with a knife, can be obtained of him at the low price of sixteen shillings.

attached a tube of the same metal E I, three inches long and half-an-inch in diameter, and provided at its lower end with a screw F, working in a nut, and having a disc K exactly

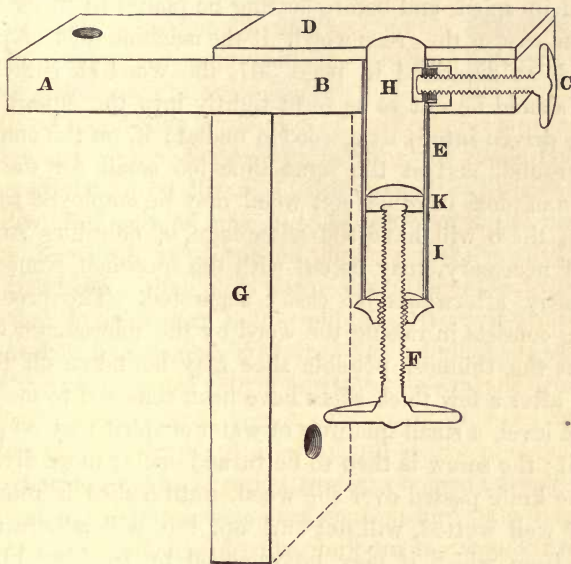

Fig. 205.

adapted to the bore of the tube; this disc is connected with the upper end of the screw, and is moved up or down by it. C is another screw connected with a curved piece of brass H, which is capable of being carried to the opposite side of the tube by it. The piece of wood about to be cut is put into the tube E, and is raised or depressed by the screw F, whilst, before cutting, the curved piece of metal H should be firmly pressed against it by the screw C. This instrument is to be fastened to the edge of a bench or table, where it may be always kept ready for use. The knife to be employed may be one constructed for the purpose, or a razor ground flat on one side will be found to answer very well.

Method of making Sections.—If the wood be green, it should be cut to the required length, and be immersed for a few days in strong alcohol to get rid of all resinous matters. When

this is accomplished, it may be soaked in water for a week or ten days, it will then be ready for cutting. If the wood be dry, it should be first soaked in water, and afterwards immersed in spirit, and before cutting be placed in water again, as in the case of the green wood. If the machine to be employed be such as described in page 307, the wood (if sufficiently large) should be cut so as to fit tightly into the square hole, and be driven into it by a wooden mallet; if, on the contrary, it be round, and at the same time too small for the hole, wedges of deal or other soft wood may be employed to fix it firmly; these will have the advantage of affording support, and, if necessary, may be cut with the specimen, from which they may afterwards be easily separated. The process of cutting consists in raising the wood by the micrometer screw, so that the thinnest possible slice may be taken off by the knife; after a few thick slices have been removed to make the surface level, a small quantity of water or spirit may be placed upon it; the screw is then to be turned one or more divisions, and the knife passed over the wood, until a slice is removed; this, if well wetted, will not curl up, but will adhere to the knife, from which it may be removed by pressing blotting paper upon it, or by sliding it off upon a piece of glass by means of a wetted finger; the plan the author generally adopts, is to have a vessel of water by the side of the machine, and to place every section in it, those that are thin can then be easily separated from the thick by their floating more readily in the water, and all that are good, and not immediately wanted, may be put away in bottles with spirit and water, and preserved for future examination. If the entire structure of any *exogenous* wood is required to be examined, the sections must be made in at least three different ways; these may be termed the transverse, the longitudinal, and the tangential; or, as they are sometimes called, the horizontal, vertical, and tangential; each of these will exhibit different appearances, as may be seen by D E F in fig. 206. At A is shown part of the stem of a coniferous plant, and a transverse section of a portion of the same magnified at D; in this is exhibited the zones *a a*, indicating the

annual growth of the stem and the radiating lines *bb*, termed the medullary rays. A vertical section B, through the pith,

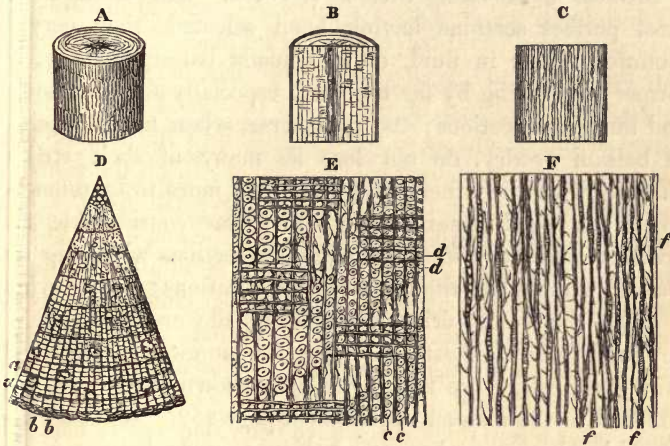

Fig. 206.

will exhibit the medullary rays, that are known to the cabinet-maker as the *silver grain*; and at E, which is a magnified view of a part of the same, may be seen the woody fibres *cc*, with their dots *dd*, and the horizontal lines indicating the medullary rays cut lengthwise; whilst at C, which is the tangential section, and F a portion of the same magnified, the openings of the medullary rays *ff*, and the woody fibres with vertical slices of the dots are exhibited. Very instructive preparations may be made by cutting oblique sections of the stem, especially when large vessels are present, as then the internal structure of the walls of some of them may oftentimes be examined. The diagram above given refers only to sections of a *pine*; all *exogenous* stems, however, will exhibit three different appearances, according to the direction in which the cut is made; but in order to arrive at a true understanding of the arrangement of the woody and vascular bundles in *endogens*, horizontal and vertical sections only will be required. Many specimens of wood that are very hard and brittle may be much softened by boiling in water; and as the cutting-machine will answer for other structures besides wood, it may here be

stated, that all horny tissues may also be considerably softened by boiling, and can then be cut very easily.

Methods of Mounting Sections of Wood.—The thinnest and most perfect sections having been selected, they may be mounted either in fluid, or in Canada balsam, or dry, the former plan being by far the best, especially for the vertical and tangential sections; the transverse, when mounted either in balsam or dry, do not lose so many of their striking characters as the others, and this is the more to be remarked when the wood has been kept for some considerable time previously in a dry state. Vegetable sections will keep very well in almost all the preservative solutions; on the whole, perhaps, the weak spirit and water and the creosote fluid will be found to be the best; they may be mounted either in the thin glass cell, page 254, or in that shown at fig. 158, page 253, and in the manner described at page 252. If the sections be dark, they may be mounted in Canada balsam in the manner described at page 278; but if they become too transparent when immersed in it, they should be first charred by being placed between two plates of glass, and subjected to the heat of an argand lamp until they turn brown, or they may be dyed with tincture of iodine, or in a decoction of fustic or logwood. Transverse sections may be mounted in this way, as they will stand the process of charring very well; but all the other kinds, especially those that exhibit large spiral vessels and dotted ducts, are best mounted in fluid. If the sections are to be mounted dry, they may be prepared in the manner before described at page 284, or they may be placed between two glasses, with bevelled edges, that are filled up with sealing-wax after the plan of Mr. Darker, before described in page 289; in all these cases, particular attention should be paid to the sections being properly dried before they are placed between the glasses, otherwise fungi are apt to grow from them.

Chippings of Wood.—An excellent method of exhibiting the medullary rays, and some of the larger vessels of the harder woods, is by making small chippings of them, or by tearing short pieces of wood in halves lengthways of the grain,

after the beginning of a split has been made by a chisel or a knife; these should be mounted on discs as opaque objects, and examined with a magnifying power from one hundred to two hundred diameters, the Lieberkuhn being employed as the illuminator.

Sections of Horns, Hairs, &c.—These may be made with the cutting-machine in the same manner as those of wood; all the very tough kinds, such as the horn of the rhinoceros, will be easily cut after having been boiled for a short time in water; they should be placed in the machine and cut whilst warm, otherwise the boiling will have no beneficial effect. If the specimens be too small to be cut to fit the hole in the cutting-machine, they may be firmly wedged up by pieces of wood. For the purpose of making sections of the porcupine's quill, the spines of the hedgehog, those of certain fish, and some of the larger kinds of whiskers and hairs, the author has adopted with success the plan of making holes in a block of soft wood, and of driving short pieces of them into the holes, as if they were so many nails; the block is then placed in the machine, and slices cut from it in the usual manner; the hairs, from being well supported on all sides, will not shrink from the edge of the knife, but will be as easily cut as the wood itself. The sections of the hairs may readily be separated from the wood by laying the wood on a piece of glass with water, and pressing them with a blunt pointed instrument, or tearing the section from around them. The substance known as *whalebone* may also be readily cut in the machine; in order to exhibit its structure in the best manner, the sections should be transverse like those of hair. The upper and solid parts of the horns of the antelope, ox, and other ruminants may also be cut in a similar way. Human and other hairs that are far too slender to be sliced separately, may be cut in a mass in the following manner:—If the hairs be made into a bundle, and be all dipped together into some thick glue and dried, the bundle will become as solid as a piece of wood; this may be cut into lengths and wedged firmly in the machine, when transverse sections of the same may be very easily made; these should be removed from the knife and mounted in

Canada balsam with as little separation as possible. Tendons, portions of elastic tissue, and other firm animal structures, when dried, may also be cut in the same manner as the specimens of wood and horn, but, unlike them, they will be found to exhibit no important internal arrangement.

All sections of horny tissues, if of a dark colour, should be mounted in balsam; they form, with very few exceptions, beautiful subjects for polarized light, besides exhibiting, in some instances, a remarkable disposition of their pigment; and in the case of human hair, transverse sections are valuable, as proving the cellular arrangement of the interior, which has been a matter of dispute with microscopists from the earliest times.

CHAPTER XIII.

ON THE DISSECTION AND PREPARATION OF VEGETABLE AND ANIMAL STRUCTURES.

By far the greater number of the wonderful and highly interesting structures which it may fall to the lot of the microscopist to examine, are not presented to him in a simple and isolated form, but are more or less combined with other tissues from which they require to be extracted or separated by a process termed *dissection*; this may be divided into two branches, one in which the subject is large and all its parts perfectly tangible and visible to the unassisted eye, whilst in the other the aid of the microscope and of very delicate instruments is requisite for its due performance; the first is called *coarse* or *rough*, the second *minute anatomy*; in both, certain cutting and other implements are necessary, which here demand our attention.

Dissecting Forceps.—In addition to the forceps already described at page 119, two or three other kinds will be necessary for the purposes of dissection: of these the most useful are represented at A in fig. 207; they should be com-

posed entirely of steel, and be at least five inches in length. They may be denominated the *straight* and the *curved*; of the first kind, or that shown at A, two pairs will be required, one

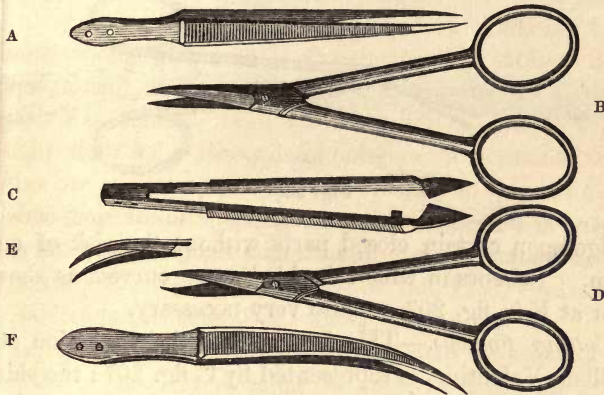

Fig. 207.

having the extremities broad, and the other sharp pointed; if large dissections be undertaken, a still stronger pair, with the extremities broad, and made rough like a file, will also be necessary. In dissecting under the microscope, the curved pointed pair shown at F will be found most convenient. In all these instruments the points should fit accurately together, sometimes those that are very sharp are apt to cross; this may in a great measure be prevented by having the branches wide at the base where they are rivetted. The points may be sharpened on a hone, and a magnifier employed to examine if they fit closely together. Those that are provided with notches at the end should have them alternate, that is, the hollow of one should be filled up by the elevation of the other, without which bodies will slip from between.

Scissors.—The scissors required by the microscopist are similar to those used by the surgeon, the handles should be straight, and the ends of both blades either sharp pointed, as shown at B in fig. 207, or one may be blunt and truncated; these last should be bent as in fig. 208; they will be found exceedingly useful for cutting open tubular parts, such as the

imentary canal of animals, when they are laid in a horizontal position in one or other of the troughs presently to be described; the blunt end serving to move aside or gradually

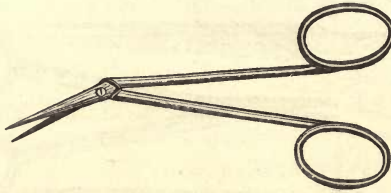

Fig. 208.

wedge open certain closed parts without the risk of cutting them. Scissors in which the blades are curved, as shown at D or at E in fig. 207 are also very necessary.

Cutting Forceps.—This instrument, the invention of Mr. William Valentine, is represented by C fig. 207; the sides are rivetted at the end, as those of the ordinary forceps, but the cutting part consists of two scissor-shaped blades, which overlap each other, and are prevented from crossing over too far by a small steel pin, the blades are bent at an angle with the sides, and by this means the instrument can be very conveniently employed for dissecting under a lens of half-an-inch focus. An instrument constructed somewhat after the same principle as the above, is known as the *Microtome*, the invention of M. Straus Durckheim; it consists of two sides, like a pair of dissecting forceps, but each terminated by a scissor-shaped blade, arranged so that its cutting edge is perpendicular to the broad surface of the side; in order to prevent the blades from opening too wide, a screw with a fly nut is attached to one blade, and the other moves freely upon it; the screw is also provided with another nut situated between the blades, the latter may be adjusted so as to prevent the blades from being closed beyond a certain point, whilst the former serves to regulate the space that the blades may be kept open by the spring. The sides are not rivetted together as in the dissecting forceps, but are united by a hinge-joint, in order that they may be separated for the purpose of sharpening the blades.

Spring Scissors.—These are represented by fig. 208, and

consist of a pair of very small scissors, whose blades are kept open by a spring *a*. One of the handles is attached to a

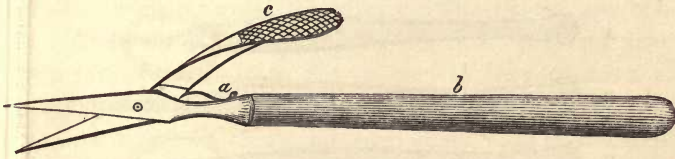

Fig. 209.

slender shaft of wood *b*, whilst the other is curved as at *c*, in order to be pressed upon by the thumb or fore-finger in the act of cutting. With an instrument of this kind, Swammerdan is said to have made all his finest dissections.

Method of Sharpening Scissors.—This may be effected by opening the blades and noticing the angle at which the edges have been previously ground, and placing them on the hone at the same angle, and rubbing them backwards and forwards, always keeping them at the same inclination; a few strokes will generally suffice for the purpose, and the blades need not be separated one from the other, provided the hone to be employed (which should be that known as Turkey stone) have a flat side that will allow of the whole of the cutting part of the blade to be rubbed upon it.

Scalpels.—The name of scalpel is generally given to the small knives employed in dissections, each consists of a blade firmly rivetted, as shown in fig. 210, into a flattened handle of ebony or ivory, which is made thin and spatula-like at its extremity. The blade may be of various shapes; those shown by A B C D E F in fig. 210, will be found most generally useful, some of them, such as B D E being formed for dissecting small animals, where the point of the blade is almost the only part employed, whilst A and F are more fitted for making long incisions in larger animals, and C for both these purposes, and for transverse sections of soft parts as well. In the absence of these, the scalpels employed in the medical schools may be used; these, however, are, generally speaking, far too large for all purposes; the small instruments

contrived for operations on the eye will be found much more suitable, and a case of the latter will be a good substitute for the greater part of the instruments above described.

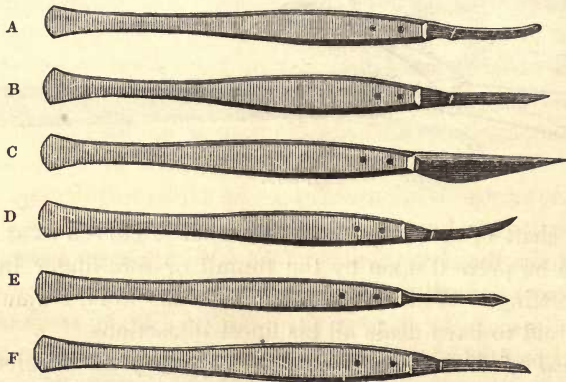

Fig. 210.



Fig. 211.

Valentin's Knife.—One of the most frequent operations in microscopical investigations is the making of fine sections; for this purpose the scalpels before noticed, or a razor may be employed, but for large substances that are soft like the liver, spleen, and kidney, the *double-bladed knife*, the invention of Professor Valentin, may be used with advantage. This, as represented by fig. 211, consists of two double-edged blades, one of which is prolonged by a flat piece of steel to form a handle, and has two pieces of wood rivetted to it for the purpose of its being held more steadily; to this blade another one is attached by a screw; this last is also lengthened by a shorter piece of steel, and both it and the preceding have slits cut out in them exactly opposite to each other, up and down which a rivet *a*, with two heads, is made to slide, for the purpose either of allowing the blades to be widely separated or brought so closely together as to touch; one head of this rivet is smaller than the hole in the end of the

slit, and can be drawn through it so that the blade seen in the front of the figure may be turned away from the other in order to be sharpened or to allow of the section made by it being taken away from between the blades. The blades are constructed after the plan of a double-edged scalpel, but their opposed surfaces are either flat or very slightly concave, so that they may fit accurately to each other, which is effected more completely by a steady pin seen at the base of the front blade. When this instrument is required to be used, the thickness of the section about to be made will depend upon the distance the blades are apart; this is regulated by sliding up or down the rivet *a*, as the blades, by their own elasticity, will always spring open and keep the rivet in place; a cut is then to be made by it, as with an ordinary knife, and the part cut will be found between the blades, from which it may be separated either by opening them as wide as possible by the rivet, or by turning them apart in the manner before described, and floating the section out in water.

Dissecting Needles.—These instruments differ but slightly in shape from scalpels; they are of two kinds, the *straight pointed* and the *curved*, one of the former is shown at fig. 188, page 277, and one of the latter by fig. 212. Both of these

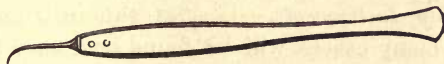

Fig. 212.

forms can be made sharp on a hone, and with either of them and a delicate pair of forceps, many very excellent dissections of small subjects, such as insects, may be made; when used in pairs, they will be found very serviceable in separating or tearing asunder delicate animal and vegetable tissues under the microscope; for this purpose a pair of the curved form will be found most convenient. As substitutes for the instruments just described, various kinds of *needle-holders* have been contrived, three of the best of these are shown in fig. 213; in all, needles of various shapes and sizes can be held firmly—

in the first and third the needle is secured by a sliding ring, and in the second by two screws; in the first and third also

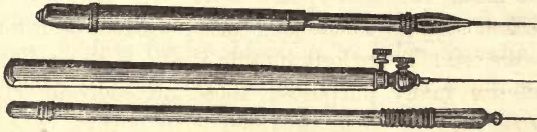

Fig. 213.

the handle is hollow to contain needles, but in the second it is solid. When needles are employed, they may be curved by making them red hot in the flame of a spirit lamp, and after they have been bent to the proper shape, they may be hardened again by heating them a second time, and dipping them in cold water or tallow. The needles selected should not be very long, as they are apt to be too springy; in these cases they should not be allowed to project far beyond the holder. Their points may be ground very sharp, or be made with a cutting edge like a scalpel, by means of a Turkey stone. These instruments are sometimes employed for mounting objects in balsam, as described at page 277; but a more common kind will on the whole be quite as convenient, and less trouble will be required in keeping them clean.*

Non-cutting Instruments.—Besides the instruments above mentioned, many others will be found necessary for the purposes of dissection; these consist principally of troughs or vessels for holding the subjects to be dissected, of blocks of wood for supporting the same, of corks loaded with lead, and of supports for the arms and wrists, termed *rests*; pins of various kinds, braces, a pair of pliers, an old scalpel or two, and a small syringe will all be occasionally required.

Troughs.—As most delicate dissections are conducted under water, some form of vessel, made either of metal, earthenware, or glass, should be employed. These may be of various sizes,

* All the various kinds of cutting instruments employed for dissecting may be obtained of Mr. Thomas Weedon, Surgical instrument-maker, No. 41, Hart-street, Bloomsbury, whose ingenuity, as displayed in their construction, is so very well known.

from a foot to two inches in length, and of a proportionate breadth and depth, if made of metal, tin, or zinc, well japanned should be used; the shape should be such that the bottom may give firm support to a loaded cork. Various descriptions of earthenware troughs are kept on sale in shops, that will answer very well for many purposes; these are certain kinds of square soap dishes, some provided with covers, others not; saucers of various sizes, small covered jars, in which potted meats, pomatum, and substances of a like kind are kept, will be found very useful occasionally. Convenient troughs may also be made of pieces of stout plate-glass, cemented together by marine-glue; their edges should be ground flat, so that another piece of plate-glass may be laid on to form a cover. Those troughs that are white in the inside may be made black with sealing-wax varnish, but in these spirit cannot be employed. The most convenient sizes for troughs in which injections are to be examined under the compound microscope, are three inches square and one inch deep, or three inches long, two inches wide, and one inch deep; much larger sizes than these cannot be well supported on the stage-plate. When small objects are necessary to be dissected by transmitted light, some of the cells described at page 260, may be employed, the plate-glass will allow the light to pass through readily. Mr. Pritchard supplies with his microscopes some little brass troughs, with glass bottoms; these can be fixed to the stage-plate by a bayonet catch, and will be found exceedingly useful.

Loaded Corks.—These consist of flat pieces of cork, of various degrees of thickness, that are covered over on their under surfaces with sheet-lead of sufficient weight to make them sink in fluid. The lead may either be cemented to the cork, or it may be cut a little larger than it, and folded over the edges rather loosely, so that when the cork is expanded by the fluid, it may not rise up in the middle. If a loaded cork is not at hand, its place may be supplied with a plate of the required size, kept steady by flat weights of lead. Some persons employ plates of wax, or some of the same substance melted into the bottom of the trough, as a substitute for the

loaded cork, but the pins do not hold in it very well. Mr. Goadby has described* a plan of securing insects about to be dissected by a mixture of white wax, flake white, Venice turpentine, and hogs'-lard; into this, when melted in the bottom of the trough, the insect was placed, and when the mixture became cold, the insect was fixed in the position required. The subject about to be dissected may be attached to the cork by pins, or some thin braces of cork, with a pin at each end, may serve to confine any part too tender either to receive a pin or that would be injured by it. Small hooks, made out of pins, needles of various sizes, and spines of *Cacti*, will all be found of essential service for the purpose of securing delicate animals to the cork.

Rests.—These consist of two inclined planes of deal or other wood, as shown at *ab*, in fig. 214, for the purpose of supporting the arms and wrists of the dissector. They may be made of the following dimensions, viz., eighteen inches long, six inches wide, and one inch thick; the upright piece to support the raised end should be about six inches high. If the trough in which the dissection is placed be large and steady, the uprights may be dispensed with, and then two plain pieces of wood resting on the sides of the trough will answer equally well. Blocks of wood, of various sizes, will be required to elevate the troughs to a particular height for dissection. The pliers will be useful for bending the pins and pressing them firmly into the cork, and the small syringe will be necessary for washing away particles of fat or other loose kinds of tissue that may be found in the interior of small animals.

* *Transactions of the Society of Arts*, Vol. L., Part ii., page 111.

CHAPTER XIV.

METHOD OF DISSECTING VEGETABLE AND ANIMAL TISSUES.

Vegetables.—The process of dissecting vegetable tissues is much more easy and less complicated than that of animals, the chief operation in the former being the separation of the woody and vascular parts from the investing cellular ones; this is effected by the combined operations of macerating and tearing, little (if any) absolute cutting being required.

For the purpose of dissecting spiral vessels, and particular kinds of woody fibres, either of the simple microscopes before mentioned will suffice; of these, perhaps, that of Mr. Slack, described at page 56, will be the best; but that of Mr. Powell, figured at page 52, or those of Mr. Ross, at pages 59 and 61, when provided with the arm rests, will be found nearly as convenient. A good idea of the structure of a plant may be known by sections made in various parts and directions by the machine, described at page 307; but the individual cells or vessels must be dissected away from the enveloping tissues before their true nature can be properly understood. The process consists of making these tissues very soft by maceration, in order that they may easily be separated from others that are more durable; the maceration should be carried on in water, which, for the purpose, should not be changed (however offensive it may become) until the parts dissected are clean enough to be mounted, as the addition of fresh water will retard the macerating process. Supposing the objects to be dissected out to be spiral or other vessels, and that by maceration the surrounding parts are soft, a portion containing the vessels must be laid either in a glass trough, or on a glass with some water, and placed upon the stage of the microscope, one part being held with the forceps, whilst another pair of forceps, or a dissecting-needle, is employed to separate all the cellular tissue from the vessels; sometimes two of the needles may be used for the purpose instead of the forceps. As soon

as the whole or any of the vessels have been sufficiently cleaned, they may be placed in some fresh water, and the process of dissection repeated until they are fit for mounting, which should be done in fluid in a thin glass or other suitable cell. When the vegetable matter is very tough, and the vessels firmly aggregated together in bundles, as in the edible rhubarb and asparagus, they may be easily separated after boiling; this plan will also answer very well for leaves that are very thick, and from which the cuticle can only be dissected with difficulty. Dilute muriatic acid may also sometimes be employed as a macerating fluid; but if the parts are subsequently to be dissected, the vegetable matter should be well washed before the steel instruments are used, otherwise they will be liable to become rusty. In such plants as the rhubarb, and various species of cactus, in which oxalate of lime abounds in stellate crystals, termed *raphides*, caustic potash may be employed to decompose the vegetable tissue; and, to save time, the potash may be heated, and, after sundry washings in boiling water, the crystals may be obtained perfectly clean. The cuticle of the leaves of many plants may be very easily removed after a little maceration; a small portion may be seized by the forceps and torn off; much larger pieces may be frequently stripped off by means of a scalpel and the thumb, the cuticle being first raised by the former, then firmly kept upon the blade by the latter, and torn in the direction in which it is most abundant. The cuticle of the *Pelargonium* tribe will be found amongst the most beautiful.

Animal Tissues.—For this purpose all the apparatus described under the head of dissecting instruments will be required. In the invertebrate series, the process resembles very much that of vegetables; after having laid open the body, the various parts may be separated or unravelled by means of the forceps and the dissecting needles, but in the higher or vertebrate series, the scissors, scalpels, and the other cutting instruments, will be in frequent demand. It would be impossible in a treatise like the present to give a code of rules applicable to all kinds of animals, but our remarks must be confined to those most generally useful to the microscopist, as full directions for

coarser dissections will be found in works devoted especially to the subject.

The dissections in which the microscope is most frequently employed, are those of the nervous system, either in small animals or in minute parts of the larger ones; for this purpose, either of the simple forms, especially that of Messrs. Powell and Lealand, described at page 52, will be found useful. The subject to be dissected may be securely fixed to a loaded cork, and be placed in a trough containing water, as shown at *c* in fig. 214; where also are represented at *a b* the two inclined

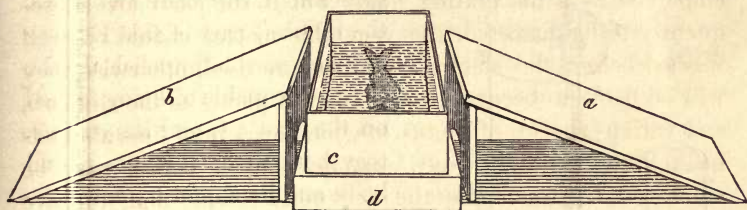

Fig. 214.

supports for the arms, termed *rests*; these, as described at page 322, consist of two inclined planes of deal or other wood, placed one on either side of the trough in which the subject to be dissected is contained, and giving firm support to the arms and wrists of the operator. If the trough be a shallow one, it may be raised on a level with the *rests* by one of the *blocks*, as shown at *d*. The microscope is to be brought over the trough, and the subject adjusted to the focus, an inch or a two-inch magnifier may be employed, or even higher, according to the delicacy of the dissection; if the subject be very minute, it may be placed in a small trough, and be dissected upon the stage of such microscopes as those represented by figs. 36-7-8, and 9. These instruments will be found particularly useful in the preparation of muscular and nervous fibres, and objects of a similar kind, previous to their examination under higher powers. The compound microscope, when provided with the *erector*, described at page 109, will answer very well for many kinds of dissection, as both the object and the dissecting instruments are not inverted, but are seen in their

natural position ; the magnifying power of the microscope can also be greatly reduced by the employment of the *erector*. M. Oberhauser, of Paris, has constructed a microscope on this principle, for the purposes of dissection, in which only one object-glass is required for all variations in the magnifying power, from eight to one hundred and thirty-five diameters. This instrument is represented by fig. 215, and consists of a

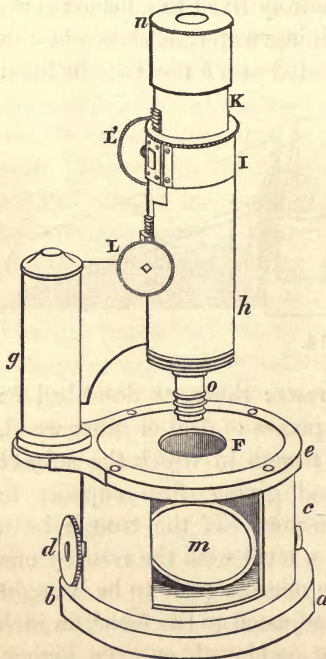

Fig. 215.

The stage is somewhat like a battledoor in shape, and to the narrow part, forming the handle, a strong support *g* for the compound body *h* is firmly attached. The compound body itself is composed of three tubes *h I K*, sliding one within the other. The outer one *h* serving for the attachment of all three to the support *g*, the next tube *I* carries the object-glass *o*, and is moved up and down by rack and pinion, the latter being connected with the milled head *L*; by means of this the focal adjustment is made. The third tube *K*, carrying the

circular foot or base *a b*, four inches in diameter, with which is connected a stout tube *c*, two inches high, supporting a stage *e*, the internal part of this *F* being of black marble unpolished; the tube *c* is capable of being turned on the foot *a b*, and the stage *e*, together with the compound body and its support *g h*, can be turned upon it. The tube has an oblong opening in front, one inch and a half broad, to allow the light to fall on the mirror *m*, and by the motion of the tube on the foot, this opening can be placed in any position to receive the light without turning either the compound body or the foot in the same direction. The mirror is inclined at any angle by means of the milled head *d*.

eye-piece n at its upper and an erector at its lower end, is also moved up and down by rack and pinion, by turning the milled head L' . By the employment of an erector at the lower end of the tube K , this microscope becomes, in every respect, similar to the compound instrument described at page 69, and objects are not seen by it in an inverted position, therefore it can be employed in dissecting. When the tube K is turned down closely upon I , the object-glass o is furthest from the object, and a magnifying power of eight diameters is obtained; but if this tube be turned out as far as it will go, the object-glass must then be brought nearer the object, and the magnifying power will be as much as one hundred and thirty-five diameters. This microscope will be found very convenient for many purposes where a great amount of defining power is not required; and as any variation in its magnifying between eight and one hundred and thirty-five diameters can be readily obtained by turning the milled heads L and L' , without the trouble of shifting the object-glass, this point alone is sufficient to entitle it to a fair share of praise. The author's attention was first directed to this microscope by Dr. John Hughes Bennett, but the description was taken from a similar instrument in the possession of Mr. C. H. Hallett.

If the subject to be dissected be a portion of injected mucous membrane, it may be pinned out on one of the loaded corks, and placed in a trough with water; and if it has previously been kept in spirit, it should be well washed in the water before examination by the microscope, for this purpose the small syringe alluded to in page 322, will be required. The subject may either be dissected under a lens, or may be from time to time examined by a compound microscope as the dissection is being proceeded with; for this purpose the instrument described at page 53 may be employed, or one of the kind represented by fig. 216, which the author has found very convenient, and is in the habit of keeping always on the table whilst dissections are being carried on. It consists simply of a tube $a b$, forming a compound body, which is capable of being moved up or down in an outer tube, supported on a

curved arm *d* by a rack and pinion connected with two milled heads, one of which is seen at *c*; the end of the support *d* is made conical at *e*, so that it may be fitted into a hole in a

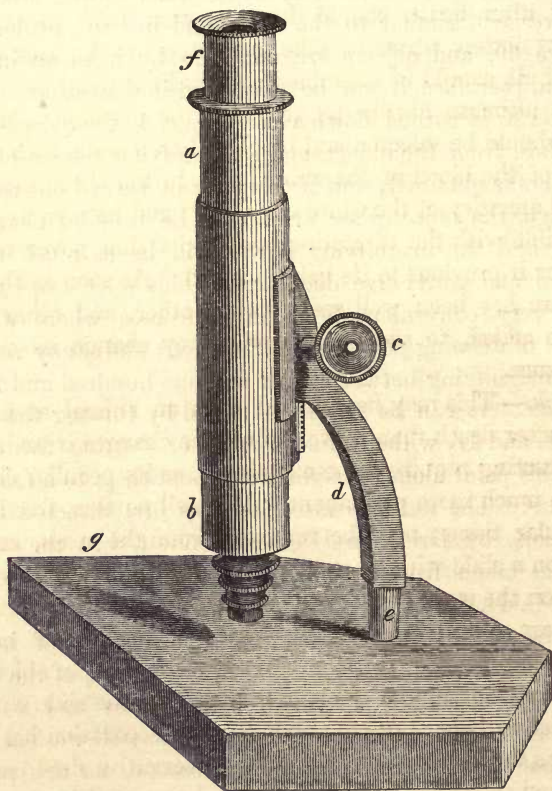

Fig. 216.

block of wood *g*; this forms the stage, and on it all the smaller troughs may be placed. The compound body so mounted will also answer for transparent objects when adapted to a stand supplied with a mirror. Such an instrument will be found exceedingly useful, and, without the object-glass and the eye-piece *f*, may be procured at a trifling cost.

DISSECTION OF PARTICULAR TISSUES.

Nerve.—The more delicate the structure of any tissue, the sooner after death should its dissection take place; thus nervous matter, whose peculiar characters are the least permanent of all, should be examined with as little delay as possible. If the ultimate fibrillæ be required for inspection, a small nerve should be selected and be placed on a slide, with a little serum of the blood of the animal; or, in the absence of this, a small quantity of the white of an egg; and be torn as gently as possible with the dissecting needles; a thin cover may be laid over it previous to its being viewed. As soon as the true structure has been well seen, water, ether, and other fluids may be added, to show how much they change its original appearance.

Muscle.—This may be selected from an animal at a later period after death than nerve (unless the changes it undergoes in contracting require to be examined), as its peculiar characters are much more permanent. A small portion, freed from all cellular tissue, may be removed from the mass, and be placed on a slide with some kind of fluid; the slide may then be laid on the stage plate of the dissecting microscope, and the fibres torn asunder by the needles, as in the case of nerve; if the parts require to be preserved in fluid as an object for future examination, the fibres may be laid on the slide without any moisture being present; and after the separation has been carried as far as necessary, then the preservative fluid may be added, and the cover laid on and sealed down with the gold-size in the usual way; when this is done there will be very little risk of the preparation shifting its place, which would happen if it were removed to another slide. The nerves of muscle may be displayed in a thin layer of delicate fibres, which form a portion of the abdominal wall of a frog; by employing the compressor, they may also be seen with the capillary blood vessels as well in some of the very thin recti-muscles of the eyes of small birds; for this purpose the eye should be removed as soon after death as possible, and the

most transparent of these muscles dissected away, and laid between glasses, or in one of the forms of compressors described at page 121 ; if this be managed carefully, the blood will be seen in the vessels, and a good view will be obtained of the comparative sizes of the nervous and muscular fibres, of the capillaries, and even of the blood particles themselves. The mode of connection of the muscular fibres with those of tendon, may also be very well studied in a preparation of this kind. The largest muscular fibres will be found in fishes and reptiles, the smallest in birds. The fibrillæ may be well displayed in the muscle of some of the crustacea, even the shrimp and the lobster will show them after they have been boiled ; but the best specimens of all may be obtained from the muscle of the pig, the very exquisite specimens, for the preparation of which Mr. Lealand has become so justly celebrated, are said to be procured from this animal. The voluntary muscular fibres of all the vertebrate animals have transverse striæ ; but the involuntary, with the exception of those from the heart, are without them. In the invertebrate series, according to Mr. Busk, the articulate animals, such as insects, have striæ ; but the other classes, such as the mollusca and cephalopoda, although higher in the scale, rarely have markings at all. The involuntary fibres are best procured by being dissected from the muscular coat of some part of the intestine or the stomach of animals ; they are more difficult of separation than those of voluntary class, and much sooner lose their characteristic structure. The fibres of old animals, and even of young ones, from want of use, sometimes undergo a fatty degeneration ; this is known by a nearly total absence of the striæ, and by the presence of numbers of oil globules instead ; these last may be known (as will be again pointed out) by their ready solution in sulphuric ether.

Tracheæ.—These may be beautifully seen in some of the small parasitic insects, when mounted either in fluid or in Canada balsam (provided the latter has not gained entrance into them, as then they will be more or less indistinct). The arrangement of the large branches, and their communication with the external orifices, termed *spiracles*, may be well

displayed in the perfect insect; but for their minute distribution upon the coats of the various viscera, as well as for their examination with high powers, the dissection of each part separately will be required. For this purpose the insect should be placed in one of the small troughs with water, and be securely fixed to a loaded cork, or to a plate of wax by pins; the body being laid open, next to the large viscera the tracheæ will become visible; the stomach or intestinal canal, if large and transparent, will exhibit the minute ramifications the best; for this purpose after being slit open and well washed, they should either be mounted in fluid, or be placed upon a slide to dry; if care be taken in the mounting, they will show very well in balsam. The best plan to pursue in these cases, in order to prevent the balsam from entering the tube, is to drop a little of it when warm upon the preparation, and before it gets quite cold, to lay on the cover (with its under surface heated), and to press it to exclude all the air bubbles and the excess of balsam. When the entire tracheal system is required to be dissected from the larva of an insect, all the viscera should be taken out, the main trunks, with their tufts of branches, will be then seen running down on either side of the body; and if care be taken in the dissection, the whole system may be removed from the visceral cavity, and be laid out on a slide to dry previous to being mounted in balsam. By far the most simple method of procuring a perfect system of tracheal tubes from the larva of an insect, is to make a small opening in its body, and then to place it in strong acetic acid; this will soften or decompose all the viscera, and the tracheæ may then be well washed with the syringe, and be removed from the body with the greatest facility, by cutting away the connections of the main tubes with the spiracles, by means of the fine-pointed scissors; in order to get them upon the slide, this must be put into the fluid and the tracheæ floated upon it, after which they may be laid out in their proper position, then dried and mounted in balsam.

The Spiracles require very little dissection, they may be cut from the body with a scalpel or a pair of scissors, and be mounted either in fluid or in balsam; very beautiful examples

may be seen in the *Dyticus marginalis*, in the larvæ of the *Blow-fly*, and the *Cockchafer*, and other equally common insects. Large tracheal vessels, when cut across transversely, will sometimes exhibit the fibre unrolling, as is often seen in the spiral vessels of plants; but the two differ in this respect, in plants the spiral fibre is situated within a membrane, whilst in insects it is between two membranes.

Having now given some preliminary directions that may be required by the microscopist for the dissection of important parts of animals in general, it only remains to describe the best method of proceeding to procure certain well known preparations from particular individuals; these will be referred to separately in that part of the work devoted to the preparation of objects of great interest.

CHAPTER XV.

METHODS OF EXHIBITING OBJECTS OF INTEREST.

Circulation of the Blood.—This wonderful phenomenon, although insisted on by the immortal Harvey, was never witnessed by him: it appears to have been first discovered in the water newt, by Mr. William Molyneux, in the year 1683.* Leeuwenhoek, the father of microscopical discoveries, was cognizant of it, and in his works are given both illustrations and descriptions of the method of examining it in a little fish and in an eel; it was also the most favourite object for exhibition with the older microscopists, and every instrument was provided with its *fish pan* and its *tube* for small eels. In more modern times the frog has been principally used for the purpose; and by the achromatic compound microscope the circulation has been witnessed in some of the smaller mammalia, in insects, in crustacea, and even in animals as low in the scale as the polypiferous zoophytes.

* *Philosophical Transactions*, Vol. xv., p. 1236.

In certain *spiders* and *insects* the circulation may be shown by placing them, without water, in an animalcule cage (which will be found to answer the purpose of the *live box* of the older microscopists), or they may be held by the forceps; in some spiders it may be seen in the legs; in insects in the transparent wings and antennæ, and sometimes in the legs: according to Mr. Pritchard, it may be witnessed in the *Perla viridis* and *Sembris bilineata*, when they have just emerged from the chrysalis. The most favourable subjects for its exhibition are those found in water, viz., certain larvæ, together with small crustacea and annelides; these may be placed for examination either in the animalcule cages, described at page 114, or in the water trough, shown at fig. 82, or even into any suitable tubular or drilled cell, and be covered over with thin glass. Amongst the most beautiful are the larvæ of the following insects, viz., the Ephemera or day-fly, the Plumed gnat, the *Hydrophilus caraboides*, and a Dragon fly named *Agrion puella*; and amongst the crustacea may be mentioned the ordinary Water-flea, or *Monoculus*, the *Daphnia pulex*, or arborescent water-flea, both of which are very common in stagnant pools, together with the fresh-water shrimp, and various species of *Oniscus* or water-hog, all of which may be examined in the water trough, or in a large animalcule cage. The circulation in the larva of the *Ephemera marginata* has been accurately described in the first volume of the *Entomological Magazine*, by Mr. Bowerbank; where also may be seen a well executed figure of the larva, as shown by the microscope. The blood is colourless, and consists of numerous oat-shaped cells or particles not contained in vessels, but which are sent to all parts of the body by the pulsation of a large dorsal vessel or heart, extending nearly the whole length of the trunk, and furnished with valves of a peculiar construction, about equal in number to the segments of the body. Besides the circulation of the blood in this animal, there are many other points of interest which may be seen with the half-inch object-glass. The structure of the valves can only be well seen when they move slowly, and then only in the three or four last segments of the body, when the vital powers

are nearly exhausted. In the *Daphnia pulex*, the oval dorsal vessel or heart may be seen pulsating rapidly on its least convex side or back, and the corpuscles of blood may be noticed in its immediate neighbourhood in an active state of movement, by a magnifying power of two hundred, or the quarter-of-an-inch object glass, when the animal is confined in a large animalcule cage. In page 41 of the second edition of the *Micrographia Illustrata* of the elder Adams, published in 1747, it is stated that the circulation could be seen in the legs and feet of small spiders, in the legs of bugs; and the movement of a greenish fluid was also to be observed in the wings of grasshoppers. Leeuwenhoek, he tells us, discovered the circulation in the shrimp, and even in the farthest joints of the legs of little crabs, which animals "may be found under brickbats and stones on the shores of the river Thames, when the tide is out." Unfortunately for the microscopist, these last no longer are to be seen in such localities. The circulation of the blood may be readily viewed in many small fishes; the older microscopists employed the eel, the carp, the gudgeon, and the flounder, for the purpose of exhibiting it; these were either confined in the fish-pan, or placed with water in small glass tubes; but the fish now commonly used is the Stickleback, *Gasterosteus*. Flounders, when sufficiently small, form very beautiful objects, but are much more rarely met with than the stickleback, which is abundant in most ponds and ditches. Amongst the reptiles, the newt and frog, and the tadpoles of each, are generally employed; in the former the circulation may be viewed in the tail, in the feet, and in the branchiæ, whilst in the latter the web of the foot, the tongue, and the branchia and tail in the tadpole, are the parts which exhibit it to the best advantage. In the mammalian class, it can be seen in the wing of the bat and ear of the mouse, and in other parts not too opaque. In some of the invertebrate animals, it will be noticed that the blood, although itself of a red colour, still its discs or corpuscles are white, the colour, unlike that in the vertebrate series, being due to the fluid in which the corpuscles float, and not to the corpuscles themselves.

Method of Viewing the Circulation in the Vertebrata.—The tadpoles of the newt, frog, and toad, when about to be examined, must be placed either in a large animalcule cage, or in the trough described at page 124, where they may be subjected, if necessary, to slight pressure. The larva of the newt, when about an inch in length, with the branchiæ external, is, perhaps, one of the most wonderful objects that can be seen by the microscope; the large blood corpuscles may even be traced as far as the extremities of the toes, but the circulation in the branchiæ is the most striking, as there the large capillary vessels are directly under the influence of the heart's action, and the movement of the corpuscles is not continuous but synchronous with that of the pulsation of the ventricle. In large newts, the circulation can only be examined in the tail; for this purpose, it will be necessary to confine them to a piece of glass or a long cell, by means of a bandage of tape; but the tail being vertical, instead of horizontal, the body must be kept firmly fixed, otherwise the tail cannot well be secured. Some persons place the animal in a glass tube with water, but unless there is some contrivance under it like Mr. Varley's *dark chamber*, the vessels cannot be seen distinctly. With fish, the plan the author has found most convenient is exhibited by figs. 217 and 218; in fig. 217,

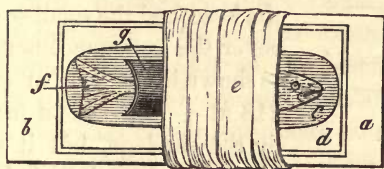

Fig. 217.

a b represents a plate of glass about three inches long, and an inch-and-a-half wide, upon which is cemented a glass cell *d*, having a long oval cavity *c* deep enough to contain an ordinary sized stickleback; to the under surface of the bottom plate of glass, at the corners, are cemented, as shown by fig. 218, four strips of plate-glass, about a quarter-of-an-inch wide, in the manner shown at *c*; these serve to raise the bottom plate in

such a manner that when the trough is laid on the stage of the microscope, the bandage *d* will not interfere with its standing perfectly flat. The bandage should be from eight



Fig. 218.

inches to a foot in length, and half-an-inch or more in width; a small piece of it should be laid in the bottom of the trough, and upon this the fish is to be placed horizontally, the bandage may then be wound round the cell and the body of the fish to secure it from kicking very much, but not so tight as to stop the circulation, taking care that all the turns are within the recess left between the strips of glass, as shown by *d* in fig. 218. Some water is now to be added, so as nearly to fill the cell, and the tail of the fish is to be spread out as shown at *f* in fig. 217. In order to prevent the tail from being flapped up against the object-glass, a thin piece of brass or other metal of either of the shapes represented by *a* or *b* in fig. 219,

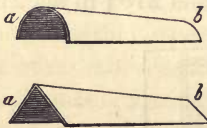

Fig. 219.

is to be placed over the body of the fish, the large end being turned towards the head, and the small so arranged as to cover the commencement of the tail, as shown in fig. 217, at *g*, and in fig. 218 at *e*. The metal may be secured by the bandage, but it should not be so long as to cover the entire length of the fish, but only about half-an-inch of the caudal extremity, otherwise the movements of the body cannot be entirely controlled. In order to prevent any of the water from being splashed out of the cell, and also to secure the object-glass from having any moisture condensed upon it, that part of the cell immediately over the tail may be covered with a piece of thin glass, which will answer both purposes; the cell must be nearly full when the glass is laid on, otherwise if a stratum of air intervene between the water and the thin glass, correct definition cannot be obtained.

Circulation of Blood in the Frog.—The part most commonly employed for this purpose is the transparent web of the hind foot; and in order to secure the animal, and keep its web open, various contrivances have been had recourse to. The older microscopists, as seen in works of Baker and Adams, were in the habit of tying the frog to a frame of brass with some fine cord; but in the present day the entire body of the animal, with the exception of the foot to be examined, is secured in a linen bag, which is fastened to a plate of brass, termed the *frog-plate*, as shown at *a a* in fig. 220,

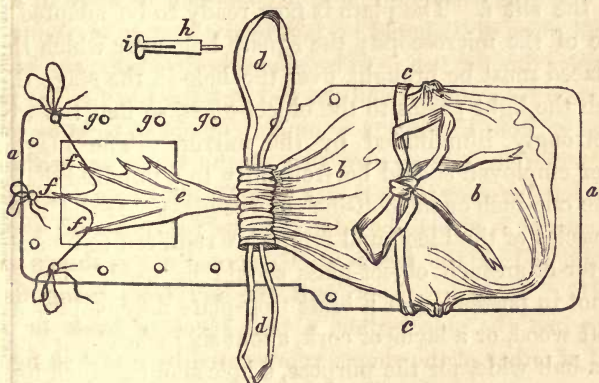

Fig. 220.

and fully described at page 125; this is so contrived as to be held firmly by some part of the stage of the microscope, and to be moved about with it. Although the shape of the plate, as constructed by our principal instrument-makers, may vary considerably, the mode of using it, nevertheless, is nearly the same in all. A linen bag should be provided, about three or four inches in length, and two-and-a-half inches broad, as shown at *bb* in fig. 220, having a piece of tape *cc* sewn to each side about midway between the mouth and the bottom, and the mouth itself should be capable of being closed by a drawing string *dd*. Into this bag the frog is placed, and only the leg in which the circulation is about to be examined kept out of the mouth, the string *dd* is then to be drawn so tight around the small part of the leg, as to prevent the foot from being pulled into the bag, but not to

stop the circulation; three short pieces of thread *fff* are now to be passed around the three principal toes, and the bag with the frog is to be fastened to the plate *aa* by means of the tapes *cc*. When this is accomplished, the threads *fff* are to be passed either through some of the holes in the edge of the plate, three of which are shown by *ggg*, in order to keep the web open, or what answers better, is a series of pegs of the shape represented by *h*, each having a slit *i* extending more than half way down it; the threads are wound round these two or three times, and then the end is secured by putting it into the slit *i*. The plate is now ready to be adapted to the stage of the microscope; the square hole over which the foot is placed must be brought over the hole in the stage through which the light passes to the object-glass, so that the web can be strongly illuminated by the mirror. The magnifying power employed should be from fifty to a hundred diameters, or the one-inch or the half-inch object-glass. If the individual corpuscles of the blood and lymph are required to be seen, the quarter-of-an-inch object-glass should be used. Those who are not in possession of a brass frog-plate may employ a piece of soft wood, or a layer of cork, about six inches long and two-and-a-half wide, for the purpose, a hole about an inch long and three-quarters-of-an-inch broad, as shown at *b* in fig. 221,

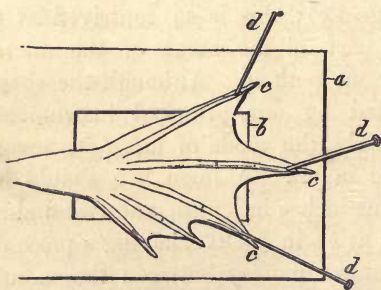

Fig. 221.

being cut through it near to one end. The frog secured in the bag, and tied to the cork in the same way as to the brass plate, is to have the web brought over the hole *b*; small pins *ddd* may then be passed through the web into the cork close to the toes *ccc* to keep it open.

This plan, although more easily managed and attended with much less trouble than that represented by fig. 220, is, nevertheless, generally looked upon by the fair sex as a much more cruel act than where the threads are employed. Some

persons adopt the plan of tying the bag containing the frog to the plate, in the manner shown by fig. 220 ; but instead of employing either strings or pins, they spread out the web of the foot upon the glass at the end of the plate ; the animal will generally keep its foot steady upon this after a few trials, especially if the glass has been previously wetted. A frog so mounted is capable of exhibiting many of the effects of inflammation ; if, for instance, a spot in the web be touched with the point of a needle, or a small drop of alcohol or other stimulating fluid be placed upon it, the circulation will stop in that part for a longer or shorter period, according to the amount of injury inflicted, the vessels in the neighbourhood will soon become turgid, and even sometimes be entirely clogged up with blood ; if no further stimulus be applied, they will be seen to rid themselves of their contents as easily as they became full, and, after a time, the circulation will be restored in every part. For those who are unacquainted with the parts which may be observed by the microscope in the foot of the frog, it may be as well here to state that the majority of vessels in which the blood is seen to circulate are veins and capillaries, the former may be known by their large size and by the blood moving in them from the free edge of the web towards the leg, also by their increase in diameter in the direction of the current ; the latter are much smaller than the veins, and their size is nearly uniform, the blood also circulates in them more quickly ; the arteries are known by their small size, and by the great rapidity with which the blood flows in them ; they are far less numerous than either of the other vessels, and, generally speaking, only one can be recognised in the field of view at a time ; in consequence of their being imbedded deeper in the tissues of the web than the other vessels, the circulation cannot be so well defined as in the latter. The black spots of peculiar shapes that occur in all parts of the web are cells of pigment, and the delicate hexagonal nucleated layer, which, with a power of one hundred diameters, can be seen investing the upper surface of the web, is tessellated epithelium.

Method of Viewing the Circulation in the Tongue of the

Frog.—The organ which, on account of the complexity of its structure, is the best adapted for examining the circulation of the blood, is the tongue of the frog, for into this enter nearly all the anatomical elements, viz., arteries, veins, capillaries, muscles, nerves, glands, membranes, &c., representing, in fact, almost every kind of organization in a small compass. The following method of preparing this organ for examination under the microscope, without endangering the life of the animal, and which can be repeated a great number of times in the same frog, has been extracted from the *London Physiological Journal*, page 125, being a modification of that recommended by Dr. Waller:—“A piece of cork, from two to three inches in breadth, and six to eight inches in length, is to be procured, in which is to be bored a hole of about half-an-inch in diameter midway between the sides, and about an inch-and-a-half to two inches from one of its ends. In this part the piece of cork should be of double thickness, which is effected by joining, by means of marine-glue, a small piece of cork upon the first piece. Upon this is laid the frog, previously enveloped in a linen band, or fixed to the cork by pins thrust through the four extremities, so as to prevent any great movements with its body or with its feet; it is placed upon the back, the end of the nose abutting on the border of the hole. The tongue, the free end of which is directed backwards, is then to be drawn out of the mouth gently with a forceps, and slightly stretched and elongated until it reaches a little beyond the opposite edge of the hole, where it is to be fastened by two pins, the sides are to be fastened over the hole in a similar way. In this state, the tongue presents the appearance of a semi-transparent membrane, which permits us to see through its substance; and when placed between the light and the object-glass of the microscope, offers one of the most beautiful and marvellous spectacles which can possibly be witnessed.” The other parts of the frog in which the circulation can be viewed, are the lungs and the mesentery; but for both these the abdominal cavity must be opened. In many of the works of the old microscopists, especially Adams and Ledermuller, are shown various contrivances for exhibiting

the circulation in the mesentery; the microscope of Lieberkuhn, described at page 17, was contrived for this purpose, and for such was employed by Ledermuller. The plan now generally adopted is to dip the frog into water at the temperature of 120° , whereby all muscular action is stopped, but the circulation still continues, the animal can then be very easily managed; as soon as the body is opened, the lungs, from being full of air, will protrude; one of these is to be taken and bent over on a piece of glass placed on the stage of the microscope, and viewed in the ordinary way, the magnificent sight then disclosed will baffle all powers of description. If the mesentery be required for the same purpose, it may, like the lung, be spread upon a plate of glass, and be examined in a similar manner.

The circulation in the mammalia is to be seen, but not so distinctly as in the reptiles, the parts generally selected being the wing of a bat and a thin ear of a small mouse; for this purpose the bodies of each animal must be firmly secured, and in the case of the former, the wing may be held down by braces of cardboard; the largest vessels will be found in the neighbourhood of the bones of the wing, from which they may be traced into the more transparent parts. The ear of the mouse is more difficult to manage; after securing the body, one of the ears, slightly compressed by a brace, may then be examined; the circulation will be most clearly seen near the edge, but at the best of times the management of this active little animal will be found very troublesome.

CHAPTER XVI.

ON THE CIRCULATION IN PLANTS.

“As long ago as the year 1774 it was known to botanists,” says Dr. Lindley,* “that a certain Abbé Corti, of Lucca, had published some remarkable observations upon the circu-

* Vegetable Kingdom, page 28.

lation of fluid in some aquatic plants, and that the accuracy of this statement had been confirmed by Treviranus so far back as the year 1817; nevertheless, the fact does not seem to have attracted general attention until the publication by Amici, the celebrated professor, at Modena, of a memoir in the eighteenth volume of the *Transactions of the Italian Society*, which was succeeded by another in the nineteenth." The plant employed by all these observers appears to have been a species of *Chara*, of which genus every species, whether opaque or transparent, will readily exhibit it; the transparent kinds without any previous preparation, whilst the opaque, from being coated with carbonate of lime, require to have this removed. Since the publication of Amici's papers, the circulation of the sap in various plants, now termed by botanists *Cyclosis*, has occupied the attention of many individuals in this metropolis; amongst the most noted may be mentioned the names of Mr. R. H. Solly, the late Mr. Slack, and Mr. Varley; to the latter gentleman we are also indebted for many valuable discoveries now about to be published in the second volume of the *Transactions of the Microscopical Society*, as well as for important apparatus for viewing the circulation, all of which will here demand our attention.

Chara.—The plant which Mr. Varley has examined so carefully is the *Chara vulgaris*, an aquatic plant, found either in stagnant, salt, or fresh water, always submerged, and giving out a most disagreeable fetid odour; its colour is green, the stem is branched and surrounded here and there with whorls of smaller branches, generally nine in number; a portion of a stem, with its whorls, is seen of the natural size in fig. 222, and magnified in fig. 223; from the centre of each whorl a smaller branch is given off; wherever this takes place, some very delicate filaments, called roots, are found to grow from the opposite side. The main tube, as shown in fig. 223, is covered throughout its entire length with eighteen smaller tubes, and is coated very thickly in some parts with carbonate of lime, which renders the stem both opaque and very brittle. Belonging to the same family as the *Chara* is a genus termed *Nitella*, in which there are several species that exhibit the

circulation, amongst them may be named the *N. hyalina* and *flexilis*; the stem of these plants consists of a single transpa-



Fig. 222.

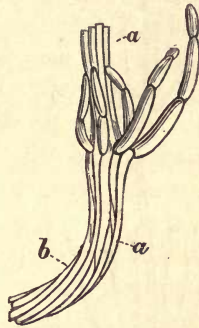

Fig. 223.

rent glassy tube of a delicate green colour, with transverse joints. In these the circulation can be viewed without any preparation, but in the *Chara vulgaris* the stem will often require to be freed from its carbonate of lime before any trace of it will be visible. A portion of the stem of *Nitella flexilis* is shown of its natural size by fig. 224; when this is compared with the *Chara vulgaris*, the difference is manifest, as the joints are not only more delicate, but there is no outer coating of small tubes, and the incrustation of carbonate of lime is a rare occurrence. A portion of the upper part of one of the stems highly magnified is represented by fig. 225; in this the arrows denote the direction of the movement, and the letters *aa* the colourless division of the joints which separate the ascending and descending currents; the circulation may even be witnessed in the whorl of young leaves at the top *s*, and in all the other parts indicated by the arrows.

Method of Viewing the Circulation.—If the *Chara* or *Nitella* be in abundance, a new piece may be selected each time for examination; but if it be scarce, and especially if it be wished to watch its development, then the plan adopted by Mr.

Varley will be found necessary. For this purpose some cylindrical wide-mouthed phials will be necessary, into each

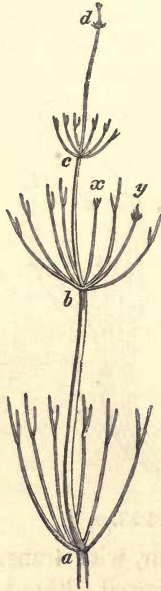

Fig. 224.

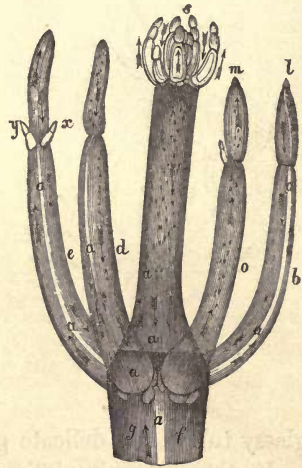

Fig. 225.

one a small branch of the plant must be put, then a thin slip of glass is to be laid over it, and kept in place by two wedges of cork, in the manner shown in fig. 226; water may now be

added to fill up the phial, and the plant is then ready to be examined. In order to do this, the phial holder previously described at page 127 will be necessary; into the tube, as there shown, the phial, previously well corked, must be placed with the plant opposite the hole; the holder is now to be fixed to the stage of the microscope, and the light reflected through the bottom tube, when the Chara may be viewed in the same manner as any other object. In order to get any part in particular into the field of view, the phial may be either turned round or slid in and out, the spring in the dark chamber will



Fig. 226.

always keep it firmly pressed against the upper part of the tube through which it is passed. This mode of treating the Chara has many advantages, not only is it always ready at hand, but the growth of any particular part can be watched from day to day, as the small specimens will frequently keep alive for many months when not exposed to too much light, and the water changed occasionally. Mr. Varley has contrived a microscope for the express purpose of holding the phial; this instrument is fully described in the fiftieth volume of the *Transactions of the Society of Arts*, and will be found exceedingly useful to those about to investigate this very interesting subject.

Soon after the circulation in the Chara and the Nitella had become generally known, the attention of microscopists was directed to discover the same phenomenon in other plants; amongst the first that yielded to a careful scrutiny was the *Hydrocharis morsus ranæ*, or *Frog bit*, an aquatic plant very common in ditches and streams. Mr. Slack has given an excellent account of it in the forty-ninth volume of the *Transactions of the Society of Arts*, from which figs. 227 and 228 are taken. Fig. 227, *a* represents a portion of the plant



Fig. 227.

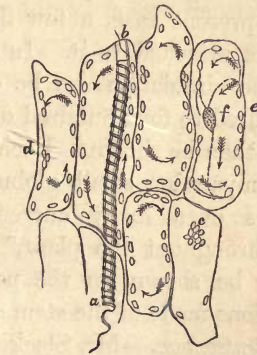

Fig. 228.

of the natural size; surrounding the leaf-buds *b* are very transparent scales, as seen at *c*; in these the circulation may be observed by placing them upon a glass slide with water,

and laying a thin glass cover over them; when viewed with a magnifying power from one hundred to two hundred diameters, an appearance such as that shown in fig. 228 will present itself; a few flattened cells of the cuticle *def* will then be seen with a spiral vessel *ab* beneath them. In each cell may be observed a motion of oblong green globules creeping round and round in the direction of the arrows; in some cells a large transparent globule or *nucleus* is seen, as at *f*; this also will sometimes be seen to circulate with the smaller globules. The circulation may also be seen in sections of the stems of the same plant; after the section has been made, the circulation is deadened or stopped for a time, but on being allowed to remain quiet for a short time in the water, it will recover its former velocity.

Tradescantia virginica—*Spiderwort*.—The circulation in the jointed hair of the filament of the anther of this plant was first discovered by Dr. Robt. Brown, in 1828, and has since that time been seen and described by other botanists, and amongst them Mr. Slack, from whose paper the magnified drawing of the hair represented by fig. 229 has been taken. It is composed of three delicate elongated cells, as shown at *bcd*, which rest upon a broader and shorter cell *a*, having, in the present case, a few flattened cells of the cuticle of the calyx attached to it. In all the elongated cells *abc*, except *d*, the circulation can be easily seen with a power from two hundred to four hundred diameters; but in *d* it can only now and then be shown. Each cell has its large *nucleus* and its accompanying small globules, as in the other plants, sometimes even many currents are seen in the same cell. "Throughout the plant," says Mr. Slack, "the circulation may be shown, in the petal even when entire, and in all sections made of the stem and leaves."

Pentstemon.—Mr. Slack has also described the circulation in a species of *Pentstemon* in the hairs taken from the throat of the corolla. One of these is shown by fig. 230, when highly magnified, it is one continuous cell projecting from the cuticle. In this hair the currents move in various directions, as shown by the arrows—some pass to the top, whilst others do not

extend half way before they return, and very often two currents unite to form one. Mr. Slack states that he never observed a nucleus in any of these hairs.

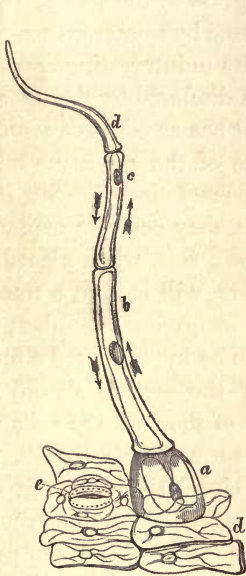

Fig. 229.



Fig. 230.

Groundsel.—The circulation in the delicate hairs found upon the leaf stalks of the common groundsel *Senecio vulgaris* was first discovered by Mr. Holland with his triplet microscope in 1832. The movement of the globules is the same, but much more delicate than in the *Tradescantia*, the *nucleus* also being present; a magnifying power of four hundred diameters, at least, should be employed to examine this delicate object; it may be seen dry or in water between glasses.

Vallisneria spiralis.—This plant is a native of various parts of the world, but in the south of Europe, the East Indies, and America, it appears to grow most abundantly. The name *spiralis* was given to it by Linnæus; but in order to distinguish it from an Italian plant of the same genus, it has been termed by Sprengel *V. Jacquiniana*. Its natural habitat is the still portions of rivers and lakes, and for the beautiful

contrivance, displayed in the mechanism for keeping its flowers above the water, it has been the theme of the poet's song. When growing, its appearance is not at all inviting, as it very much resembles so much grass in the water, the long thin leaves being secured to the mud by numerous white hair-like roots. But to compensate for its uninteresting appearance, the phenomenon of the circulation disclosed by the microscope is, without doubt, the grandest that has as yet been seen in the whole vegetable kingdom. If one of the leaves be laid on a glass slide, and a sharp knife be passed along it with its back slightly elevated, so that its edge may come in contact with the leaf, a thin slice may be cut off; this, when placed under a power of two hundred diameters, will exhibit a number of oblong cells, more or less full of green granules; these, generally speaking, will be found to be in continued circulation round the walls of each cell. If the section should chiefly consist of the outer part or cuticle of the leaf, the cells will be small, and the green globules, termed *chlorophylle*, in the greatest abundance, but rarely circulating; if the section should extend through the middle of the plant, numerous elongated colourless cells will then be seen with green particles only present on the margins, and these in active circulation, and accompanying them a large, more or less transparent, nucleus; the movement of the granules is more plainly seen than in the *Chara* and *Nitella*, on account of the transparency of the cells, and also by reason of the great contrast between the colour of the cell wall and that of the granules. The circulation also will be frequently found to vary in its direction in two cells lying side by side, which is another material point in which it differs from all the tribe either of *Chara* or *Nitella*.

Best method of Viewing the Circulation.—For this purpose, in the summer months, when the plant is in its most vigorous state, any one of the leaves may be taken, and after having been cut in the manner previously described, and laid upon a slide with water, and covered with a piece of thin glass, or placed in an animalcule cage, the chances are that it will exhibit the circulation; if not, a little heat applied to it, either

by adding some warm water, or by placing the slide for a few seconds over an argand lamp, will often start it off. In the winter, the leaves that are turned a little yellow, or even those which appear dead, will often show it the best; these should be cut some little time before they are wanted, and be placed in warm water immediately; or, what has often succeeded with the author, is to place them in a small bottle with water, and carry this in one of the pockets of the dress in which there is the greatest amount of heat. Whenever the leaf has been cut, the circulation will be deadened for a time; but heat applied in one of the ways above directed, will generally be the means of restoring it to its former state of activity.

Method of Cultivating Chara, Vallisneria, &c.—Mr. Varley, who has had great experience in these matters, addressed, in 1840, a letter to the editor of the *Microscopical Journal* on the subject; and as no better description than this can be given, the author has thought proper to transcribe it nearly verbatim:—

“In cultivating these plants,” says Mr. Varley, “it is only requisite to take notice of the circumstances under which *Chara* naturally thrives, and to imitate them as nearly as practicable.

“Firstly. The *Chara* tribe is most abundant in still waters or ponds that never become quite dry; if found in running water, it is mostly met with out of the current, in holes or side bays, where the stream has little effect, and never on any prominence exposed to the current. If the *Chara* could bear a current, its fruit would mostly be carried on and be deposited in holes; but it sends out from its various joints very fine long roots into the water, and these would by agitation be destroyed, and then the plant decays; for although it may grow long before roots are formed, yet, when they are produced, their destruction involves the death of the plant. In order, therefore, to preserve *Chara*, every care must be taken to imitate the stillness of the water, by never shaking or suddenly turning the vessel. It is also important that the *Chara* should be disturbed as little as possible, and, if requisite, it must be done in the most gentle manner, as, for instance, in cutting off a

specimen, or causing it to descend in order to keep the summit of the plant below the surface of the water.

“Secondly. Imitate the freshness of the water, by having an extent of surface, which it is requisite to skim frequently, or suffer it to overflow by the addition of more water. These precautions being attended to, a clear bright surface is kept. It is also desirable to change a small portion of the water; but this should be done without agitation. The best vessels for cultivating this plant in, are either wide pans, holding three or four gallons, or glass jars a foot or more high; into these the Chara may be placed, either with clean water alone, or a little earth may be sprinkled over it, so as to keep it at the bottom, or the bottom may be covered one inch with closely pressed mould, in order that the water may be put in without disturbing it. On this lay the Chara, with a little earth over the lower ends, to fix it. By causing the water to overflow is the readiest way to skim the surface, though dipping out gently will do; but in all cases of pouring in water, hold something, such as a saucer or flat piece of wood, to receive the pouring, and make it spread instead of allowing it to descend at once on the surface. Pans in the open air, nearly full of water, will be kept in order by the wind and rain, only taking care to supply the deficiency (the effect of evaporation), and to change some of the water, if it be considered necessary. The vessels kept in-doors have a film which is always forming on the water, and which requires to be frequently removed.

“Thirdly. Imitate the equal temperature of its native holes, by sinking the pan a little within the earth; but, during frosty weather, keep the pan in-doors, and at the lower part of the house, as this situation is generally the most uniform in its temperature.

“The Chara will live in any temperature above freezing, and grows quicker as the warmth increases; but above the earth, as outside of a first-floor window, it will not bear the daily difference between the mid-day sun and the cold of sun-rising.

“The glass jars I keep within the house, as nearly uniform in warmth as convenient.

“ Similar care is requisite for *Vallisneria*, but the warmest and most equal temperature is better suited to this plant. It should be planted in the middle of the jar in about two inches deep of mould, which has been closely pressed; over this, place two or three handfuls of leaves, then gently fill the jar with water. When the water requires to be changed, a small portion is sufficient to change at a time. It appears to thrive in proportion to the frequency of the changing of the water, taking care that the water added rather increases the temperature than lowers it.

“ The natural habitat of the Frog-bit is on the surface of ponds and ditches; in the autumn its seeds fall, and become buried in the mud at the bottom during the winter; in the spring these plants rise to the surface, produce flowers, and grow to their full size during summer. In order to keep them for microscopic purposes, large pans, with earth at the bottom, will preserve them through the winter; and if left out of doors during the cold months, the pans should be sunk into the ground to preserve the buds from the extreme cold.”

The author has found the following a very convenient way of changing the water in the *Chara* and *Vallisneria* jars, viz., to place the jar occasionally under the tap of a water tank, and allow a very gentle stream to flow into it for several hours; by this means, all the impure water and conferva growing on the sides of the vessel may be got rid of.

Habitat.—In the neighbourhood of London, the *Chara vulgaris* may be found abundantly in the Isle of Dogs, in ditches near the bank of the Thames; also in some of the ponds on the Hippodrome, at Notting-hill. The *Nitella* grows in ponds at Totteridge and Hendon, whilst the *Hydrocharis* occurs in almost every ditch, and may be known by its flat leaf, somewhat like that of a large species of duckweed, floating on the surface of the water. The *Tradescantia* and *Pentstemon*, as well as the groundsel, are common in flower gardens; but the *Vallisneria* is principally cultivated by the microscopist; small roots of this plant may, however, be obtained of Mr. Topping, and of some nurserymen.

CHAPTER XVII.

METHODS OF PROCURING INFUSORY AND OTHER
ANIMALCULES.

THE term *Infusoria* was given by the older microscopists to beings which, previous to their discovery by magnifying powers, had been concealed from observation by the minuteness of their size. They were first detected in water containing vegetable matter, such as hay and grass in a state of decomposition; it was then supposed that they were peculiar to infusions of a certain kind, hence their name. The celebrated Ehrenberg, who has devoted himself so entirely to their structure and classification, has divided them into two orders, *Polygastria* and *Rotifera*; the first being named from their having many stomachs, and the last from their being provided with vibratile organs resembling wheels. Amongst the most remarkable of the *Polygastria* may be included the following genera, viz., *Monas*, *Gonium*, *Volvox*, *Vibrio*, *Navicula*, *Stentor*, and *Vorticella*; whilst amongst the latter may be named the *Floscularia*, *Stephanoceros*, *Brachionus*, and *Rotifer*.

Localities.—The ordinary forms of *Infusoria* are to be met with in all kinds of stagnant and putrid water, whilst the more highly organized are only to be found in clear ponds and in streams where they attach themselves to the stems and under sides of the leaves of aquatic plants, or even to small pieces of wood or other vegetable matters that are either floating or are kept beneath the surface of the water. Some kinds are found near the surface, others in the mud at the bottom, all of which localities should be carefully searched.

Apparatus.—For the purpose of collecting these interesting creatures, the following simple apparatus will be required, viz., some clear wide-mouthed phials or tubes capable of being well corked, a walking-stick or jointed rod, provided with a ring at the end for holding the phials, a small aquatic net of muslin strained upon a hoop of wire, and a pocket magnifier.

Fig. 231 represents the various instruments that will be found necessary; at *a* two joints of a fishing-rod of cane are shown, the top joint, for convenience of package, being made to slide within the lower one. To the upper end *b* is screwed a steel ring of the shape represented by 'b, for the purpose of holding the phial as seen at *c*; into the same handle may be fitted the hoop *d*, having a bag of fine muslin attached to it; this may be of the shape there shown, or brought to a fine point. In the absence of this apparatus, a stick, as exhibited at *e*, having a split at one end, may be employed; into this the neck of the phial *f* is to be placed and kept firmly fixed by winding a string round it, as shown at *g*. Mr. G. Shadbolt, jun., who has paid some considerable attention to these matters, has lately recommended to the author the following plan of securing the phial to the stick, which will be found worthy of a trial. Fig. 232, A is a piece of brass about three-eighths of an inch square, with two projecting pieces *a a*, through one of which a screw with a flat head works. One end of the brass piece *c* is made cylindrical, about half an inch in diameter, with a female screw *d*, into which a male screw on the stick is made to work. Two screw holes *ee* are made in one side of the brass A, for the purpose of attaching permanently to it by screws the spring B, having two holes *ff*, made in it for the purpose. The phial being placed

Fig. 231.

pieces *a a*, through one of which a screw with a flat head works. One end of the brass piece *c* is made cylindrical, about half an inch in diameter, with a female screw *d*, into which a male screw on the stick is made to work. Two screw holes *ee* are made in one side of the brass A, for the purpose of attaching permanently to it by screws the spring B, having two holes *ff*, made in it for the purpose. The phial being placed

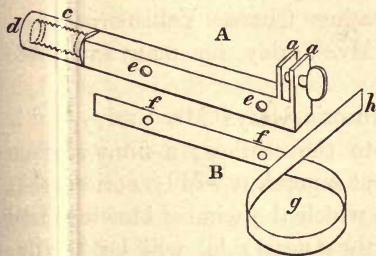

Fig. 232.

holes *ff*, made in it for the purpose. The phial being placed

in the loop *g*, and the spring being drawn close by pulling the end *h* between the cheeks *a a*, the flat-headed screw is turned, and the phial will be firmly held.

⑧ The spring may be made of steel, or of moderately thin whalebone, which can be used in preference, as it will not spoil by being wetted, and, for the same reason, the other part may be made of brass.

A tin box *h*, Fig. 231, containing six or twelve short glass tubes, provided either with plain corks, or with corks through which a piece of glass tube or quill has been passed in the manner shown at *i*, will be found very convenient for all the smaller kinds of infusoria.

The fishing tubes have already been described at page 118; these will be useful for separating the large voracious animals from the more delicate ones.

The pocket magnifier may be of either of the forms shown by figs. 23 and 24, or the Coddington lens, represented by fig. 26, when the infusoria are very minute. Dr. Arthur Farre has lately shown the author a convenient form of lens, which he finds very useful for most of the marine Polypes; this consists of two double-convex lenses of different focal lengths, placed in a setting with an ebony stop between them, somewhat in shape like an hour-glass. This lens performs like a doublet or Coddington; and, although of long focus, nevertheless, magnifies considerably.

Method of Obtaining Infusoria.—In order to be successful in the capture of these minute creatures, a knowledge of their habits must be first acquired, and upon this matter, as well as upon the method of cultivating Chara, Vallisneria, &c., the author is indebted to Mr. Varley for many valuable instructions.

“The tendency of all infusoria,” says Mr. Varley,* “is towards the light, and also to the surface; a filmy surface will hold many. On arriving at a pond, it will be noticed that the ‘off side,’ or that towards which the wind is blowing, will be coated with scum, whilst the ‘near side’ will be bright; these sides will differ materially in the quantity of animalcules

* In a letter to the author.

they may contain, the bright side being often without any ; if the wind blows towards the sunny side, that side will be especially prolific. Shallow parts being warmer than deep, will also yield a more abundant supply."

"The rod with the phial attached, as shown in fig. 231, is to be carried into the water in such a manner that the phial may be kept in an inverted position, and when arrived at the proper depth, the rod is to be turned, and the mouth of the phial will then be in the position to receive the water, which will run in rapidly, and carry both animalcules and weeds in with it. The contents of the phial may be then either viewed with a pocket lens, or poured into another phial and then examined ; if any animalcules be present, and worth keeping, they may be corked up for further inspection. Dips should be made both among *confervæ* and duck-weed, and portions of the weed allowed to enter the phial ; a dip also among rushes is frequently very rich ; the phial should be shaken about as it is being turned up to receive the water. If the phial be a very wide-mouthed one, a sudden dip amongst large weeds will afford very many kinds ; these, after examination, may be placed in smaller phials, and corked up for further inspection at home. If any larvæ, or other voracious kinds are present, they should be removed with one of the fishing tubes, otherwise they will destroy nearly all that come in their way before the collector reaches home. For all the larger kinds, such as the *Monoculus* and *Cyclops*, the net shown at *d* in fig. 231 will be required ; if this be dipped very suddenly under weeds, and be as suddenly lifted up, they will be caught ; by holding the bottom of the net in the water and the ring out, all weeds that are in the way may be removed, and the produce then poured into a phial with a small quantity of water, and the voracious ones taken out by the fishing tubes in the manner before described. If the Water-fleas and *Daphniæ* be very abundant, they may be got rid of in the following manner :—as soon as they are placed in the phial, they go very quickly to the bottom ; if, therefore, the upper water be poured into another phial, the bottom containing them may be thrown away ; if, also, the phial be

shaken about in the water before it be turned over to be filled, they will generally have darted away. Small newts, and many larvæ, should be taken great care of, the former especially, as, when young, their branchiæ are present; in these and in their feet, the circulation of the blood is most beautifully seen; they will also be found of essential service for eating up the Daphniæ, Monoculi, and the various larvæ that destroy the different kinds of vorticellæ. The inverted phial should be carried to the bottom of shallow ponds, and, whilst laid horizontally, the surface of the mud should be scraped, the phial, when quite full, may be corked to prevent shaking; at home the mud may be put into a large jar, and filled up with water, in a day or two the animalcules will have come to the surface of the subsided mud, from which they may be taken away quite clean by means of a fishing tube. When water has quite left a pond, a box or phial full of the surface mud should be taken home and treated in the same way as the more liquid kind above described. In order to preserve the infusoria and other large animalcules at home, the conditions under which they have been found should, in all cases, be closely imitated. Such plants as will live in water without much mould, and not speedily decay, should be selected; these will all tend to keep the water healthy for the animalcules, and also serve as food for them; the plan adopted for preserving the plants should be the same as that already alluded to in page 349, the larvæ of the Ephemera and small snails being employed to free them from conferva which will be found to interfere with the growth of most aquatic plants."

Method of Obtaining and of Keeping Hydras.—One of the most extraordinary aquatic animals that the microscopist is likely to procure in his searchings in pools and ditches, is that known as the Hydra, or fresh-water Polype; it appears to have been first noticed by Leeuwenhoek, in 1703, but it was reserved for the inquiring genius of M. Trembley, then residing at the Hague, in 1739, to discover its wonderful powers of reproduction. In England there are as many as four or five varieties; one of them is of a delicate green colour, whilst the others are more or less yellow or brown;

each one, when in an expanded state, consists of a long semi-transparent tubular body, from one end of which protrude several long delicate arms or tentacula, varying in number in the different species, six or twelve generally being the two extremes. Within these arms is a mouth capable of being dilated, so as to receive animals nearly as large as the size of the Polype itself. In the contracted state, the animal appears like a small round ball, the arms being drawn in so far that they only resemble small papillæ. M. Trembley thought they were very analogous to vegetables, and, to satisfy himself upon this point, he cut several of them in pieces, and, to his great astonishment, found that each cut portion became a perfect animal. Some of these Polypes having been sent to England, the experiments of M. Trembley were tried with entire success by many of the learned, but more especially by Mr. Henry Baker, who published a book on the subject, in 1743, which will well repay an attentive perusal. The Hydræ are generally found in ponds and rivulets, adhering either to portions of weed or sticks; they may be readily seen by the naked eye when placed in a clear glass jar. In order to take them home safely, they should be put into clean phials, with a small portion of some aquatic plant, and the phial filled with water; it should be carefully corked, both to prevent the water from being spilt and the Hydræ from being injured. At home they should be kept in tolerably large glass jars, in clear river water, with a small plant growing in it; being very voracious, they will require to be often fed; the best animals to give them are the small red-blooded worms (Naiides) that are so common on the banks of the Thames, to the mud of which they impart a red colour; these should be well washed in clean water before the Polypes are fed with them, and the Polypes themselves placed in pure water after every meal; the common water-fleas, in the absence of Naiides, will also serve them as wholesome food. The mode of generation of Polypes is by *gemination* or budding, and takes place very rapidly, as many as four or five young ones in a week having been known to be produced; as soon as a young one is provided with arms, it will devour the worms with as much

eagerness as the older ones. When placed in great numbers in one phial, they do not thrive so well as when they are in small quantities, hence they should be occasionally moved from one jar to another; this may be readily managed by the end of a quill, or a fine camel's-hair pencil. They are best examined either in one of the troughs shown by figs. 82-3, or in a large animalcule cage; and can be easily divided by a pair of sharp-pointed scissors, like those exhibited at B in fig. 207. Those who would wish to know the results of the various operations, should consult the excellent works of M. Trembley and Mr. Baker, which will give them full particulars.*

Desmidiæ.—Another most interesting class of objects for the microscope, but now generally considered as belonging to the vegetable kingdom, are the *Desmidiæ*, a tribe of lowly organized plants, remarkable for the elegance of their form and for being found exclusively in fresh water. They have lately been classified and arranged by Mr. Ralfs in an admirable work on the subject, which should be in the possession of every microscopist. As the mode of collecting them differs somewhat from that of the Infusoria, the author has thought proper to borrow Mr. Ralfs' description:—

“As the *Desmidiæ* are unattached and very minute, they are rarely gathered in streams; nevertheless, interesting species may occasionally be obtained where the current is so sluggish as to permit the thin retaining mucus to elude its force. In small shallow pools, that do not dry up in summer, they are most abundant; hence pools in boggy places are generally productive. The *Desmidiæ* prefer an open country. They abound on moors and in exposed places, but are rarely found in shady woods or in deep ditches. To search for them in turbid waters is useless: such situations are the haunts of animals, not the habitats of the *Desmidiæ*, and the waters in which the latter are present are always clear to the very bottom. In the water, the filamentous species resemble the

* *Memoires pour servir à l'Histoire d'un Genre de Polyces d'Eau douce.* Par A. Trembley, de la Societè Royale. A Leide, 1744. *An Attempt towards the Natural History of the Polype.* By Henry Baker, F.R.S. London, 1743.

Zygnemata, but their green colour is generally paler and more opaque. They often occur in considerable quantity, and, notwithstanding their fragility, can generally be removed by the hand in the usual manner. When they are much diffused in the water, I take a piece of linen, about the size of a pocket-handkerchief, lay it on the ground in the form of a bag, and then, by the aid of a tin box, scoop up the water and strain it through the bag, repeating the process as often as may be required. The larger species of Euastrum, Micrasterias, Closterium, &c., are generally situated at the bottom of the pool, either spread out as a thin gelatinous stratum, or collected into finger-like tufts. If the finger be gently passed beneath them, they will rise to the surface in little masses, and with care may be removed and strained through the linen, leaving only a mere stain or a little dirt; but by repeated fillings up and strainings, a considerable quantity will be obtained. If not very gelatinous, the water passes freely through the linen, from which the specimen can be scraped with a knife, and transferred to a smaller piece; but in many species the fluid at length does not admit of being strained off without the employment of such force as would cause the fronds also to pass through, and in this case it should be poured into bottles until they are quite full. But many species of Stauroastrum, Pediastrum, &c., usually form a greenish or dirty cloud upon the stems and leaves of the filiform aquatic plants, and to collect them requires more care than is necessary in the former instances. In this state, the slightest touch will break up the whole mass, and disperse it through the water. I would recommend the following method as the best adapted for securing them. Let the hand be passed very gently into the water and beneath the cloud, the palm upwards and the fingers apart, so that the leaves or stem of the invested plant may lie between them and as near the palm as possible; then close the fingers, and keeping the hand in the same position, but concave, draw it cautiously towards the surface, when, if the plant has been allowed to slip easily and with an equable movement through the fingers, the Desmidiæ, in this way brushed off, will be found lying in the palm. The greatest

difficulty is in withdrawing the hand from the surface of the water, and probably but little will be retained at first; practice, however, will soon render the operation easy and successful. The contents of the hand should be transferred at once either to a bottle, or, in case much water has been taken up, into the box, which must be close at hand, and when this is full, it can be emptied on the linen as before. But in this case the linen should be pressed gently, and a portion only of the water expelled, the remainder being poured into the bottle, and the process repeated as often as necessary. Sporangia are collected more frequently by the last than the preceding methods. When carried home, the bottles will apparently contain only foul water; but if it remain undisturbed for a few hours, the Desmidiæ will sink to the bottom, and most of the water may then be poured off. If a little fresh water be added occasionally to replace what has been drawn off, and the bottle be exposed to the light of the sun, the Desmidiæ will remain unaltered for a long time. I have now before me some specimens of *Euastrum insigne*, the fronds of which are in as good condition as when I gathered them at Dolgelly five months ago."

Localities for Infusoria.—All the smaller kinds are found in vegetable infusions, or in fluids where either vegetable or animal matter is decomposing, but the larger kinds are only to be met with in clear pools and streams, where they are either found swimming about, or else congregated around, or attached to the under surfaces of the leaves or to the stems of aquatic plants. All the ordinary ditches and ponds in the neighbourhood of the metropolis will yield the more common forms, but there are certain localities in which some of the more highly organized can only be collected. A pond near "Jack Straw's Castle," on Hampstead Heath, is very famous for the *Volvox globator*, the arborescent *Vorticella*, and for many species of *Rotifer*. According to Dr. Mantell,* in a lake behind *Grove House*, on Clapham Common, in which the white water-lily grows, the splendid *Stephanoceros*, or crowned

* *Thoughts on Animalcules*, by G. A. Mantell, Esq., L.L.D., London, 1846, page 63.

animalcule, was found by Mr. Hamlin Lee; it has since been met with in other ponds, but most abundantly in that called the *Black Sea*, on Wandsworth Common, near the railway station. A small pond in the garden of Mr. B. Edwards, in Shoreditch, has been long noted as having supplied microscopists, at one time or other, with almost every variety of the more highly organized Infusoria. A large cistern, on the premises of Mr. Rosling, near Southwark-bridge, has afforded a great variety of interesting forms, and amongst them two kinds of fresh water Zoophytes, viz., *Fredericella* and *Cordylophora*. The *Alcyonella*, and several species of fresh water sponge, are to be met with in the Commercial Docks. The *Stentor cæruleus* has been found abundantly by the author in ditches which communicate with a small stream in the Isle of Dogs, close to the timber dock that opens into the West India South Dock. The *Daphniæ* are very abundant in the summer months in the dock waters, to the surface of which, in the evening, they communicate a red colour, known to the common people as *spawn*. The *Branchipus stagnalis*, a highly interesting crustacean, is found in small pools of soft water on Blackheath: care must be taken in managing it, as it rarely lives more than a day or two. In the mud of many ponds may be obtained very interesting forms of *Navicula* and *Diatomea*; in the mud of the Thames, at various localities, such as Lambeth, Woolwich, Tilbury, and Greenhithe, have been discovered *Xanthidia*, and a very beautiful genus termed *Triceratium*. In the mud of the Humber, near Hull, have been found two beautiful species of *Navicula*, termed *hippocampus* and *angulata*, the former being an excellent test of a quarter-of-an-inch object-glass, the latter of an eighth or twelfth; both these will be shown highly magnified with the other test objects at the end of the work. In the white pearly matter often seen in peat bogs, and in the neighbourhood of swampy pools, will be found an abundance of *loricæ* or shells of Infusoria; the most favourite localities being the bogs of Ireland, Scotland, and Yorkshire. The sea shore and marine plants yield a variety of beautiful forms; the guano, from different parts of the world (as will be again noticed), the

stomachs of oysters, scallops, and other Mollusca, all abound in some of the most elegant species of a genus named *Coscinodiscus*, these being often associated with others in a fossilized state.

The Locality of the Wheel Animalcule.—Microscopists, from the time of Baker, have nearly all stated that the wheel animalcule is to be found in a reddish kind of slime deposited from water that has been standing in leaden gutters, or even in the dust that remains after all the water has been dried up; which, when again moistened, will seldom fail to exhibit them. Capt. Ford, after having sought in vain to procure them from the localities above described, tried several other plans for the purpose; but the following he recommends as the best:—“Early in the spring he fills a three-gallon jug with pure rain-water (not butt-water, because it contains the larvæ of gnats), from this he takes a sufficient quantity, nearly to fill a half-pint jug; he then ties up a small portion of hay or green sage leaves into a bundle, and places the same in the mug; about every ten days he removes all the decayed portions with a piece of wire, and substitutes a fresh supply; a little of the deposit scraped from the side of the mug near the surface, when placed under the microscope, will be certain to exhibit them. As the water evaporates from the mug, the excess of rain-water in the large vessel will supply the deficiency. The sage leaves were found to produce the largest numbers. The same mug,” Capt. Ford also states, “for the seven years preceding the date of his note (in 1841), had never failed to yield an abundance.” If the animalcules be kept in glass bottles, they should not be exposed to a direct light; in a room they may be placed in a dark corner, or upon a table between two windows, so long as the light that is allowed to fall on them is diffused; they will then thrive very rapidly.

Method of Feeding Infusoria with Carmine.—In order to display the currents made by the cilia of these minute animals, as well as to exhibit the form of the digestive system, a certain amount of colouring matter introduced into the water con-

* *Microscopical Journal*, vol. i., p. 96.

taining them will render both more evident. This plan was first employed by M. Trembley, without any important result; but Ehrenberg followed it up more carefully, and was led to the discovery of the internal structure of those infusoria which he subsequently termed *Polygastria*.

The method of proceeding is to rub some pure sap green, indigo or carmine upon a palette or a plate of glass, and to add to this a few drops of water; if the glass be now held on one side, a portion of the water containing a certain amount of the colouring matter may be dropped upon the tablet of an animalcule cage, or into the water in which the animalcules are contained; if they be *vorticellæ* or *rotiferæ*, the particles of colouring matter will show the vibratile actions of the cilia, whilst other particles, when swallowed by the animalcules, will give a rich tint to the various compartments of their alimentary canal. If the animalcule cage be a large one, a very small quantity of the carmine may be rubbed upon one part of the tablet, and the water containing the animalcules being placed upon it, may be mixed up with the carmine in the usual manner. Of the three colours, the sap-green will be most easily swallowed by the insects, although the carmine shows best in the water, whilst the indigo is not so easily managed as the other two. The colours when employed should be of the purest kinds, otherwise the animalcules will not easily swallow them, or, if swallowed, the death of the creature will speedily result.

FOSSIL INFUSORIA.

An endless variety of Infusoria are met with in the fossil state, the siliceous skeletons of which have become aggregated together in such immense masses, that not only are vast tracts of country and chains of mountains formed of them, but even strata, several yards in thickness, upon which cities are built. Amongst the first discovered of the infusorial strata were the polishing slates of Bilin and Tripoli, then the Berg-mehl or Mountain meal, of which almost the entire mass is composed of the siliceous skeletons of different species of

Navicula and Bacillaria. In more modern times, the American Continent has, through the researches of Professor Rogers, furnished remarkable examples of infusorial sand-stone; one of these, at Richmond, in Virginia, is many miles in length, and, in some places, as much as fifteen feet in thickness. The great mass of chalk, as seen in the cliffs and rocks of our coasts, is made up principally of minute foraminiferous shells; the flints also, which are so abundant in the chalk, are now generally considered to be composed of animal remains, and in them may be found fish scales, bones, spicula of sponges, Xanthidia, shells of various kinds, and numerous small Zoophytes.

One remarkable fact, in connection with fossil Infusoria, is that most of the forms may be still found in the recent state. The beautiful engine-turned discs (*Coscinodisci*), so abundant in the Richmond earth, may be met with in our own seas, also in great profusion in the deposits of *Guano* on the African and American coasts, and even in the stomachs of the oyster, scallop, and other molluscous animals so common on all our shores.

Method of Preparing Fossil Infusoria.—A great number of the infusorial earths may be mounted up as objects without any previous washing or other preparation, by the method described at page 281, but some, such as chalk, must be repeatedly washed to deprive the infusoria of all impurities; whilst others, and these by far the most numerous, require either to be digested for a long time, or even boiled in strong nitric or hydrochloric acids for the same purpose. Supposing the earth about to be prepared be some of that from Richmond, in America, a small portion having been placed in a test tube (or other convenient vessel capable of bearing the heat of a lamp), enough diluted hydrochloric acid is to be poured upon it to about half fill the tube, brisk effervescence will now take place, which may be assisted by the application of a small amount of heat, either from a sand bath or from a lamp; as soon as the action of the acid has ceased, another supply may be added, and the same continued until no further effect is produced; strong nitric acid should now be substituted for

the hydrochloric, when a further effervescence will take place, which also may be greatly aided by heat; after two or three fresh supplies of this acid, distilled water may be employed to neutralize all the remains of the acid in the tube, and this repeated until the water comes away perfectly clear, and without any trace of acidity; the residue of the earth, which consists of silica, will contain all the infusorial forms; some of this may be taken up by a fishing-tube, and laid on a slide and examined in the usual manner; should perfect specimens of the *Coscinodiscus*, *Gallionella* or *Navicula* be present, they may be mounted in Canada balsam in the manner described in page 281, if not, the slide may be wiped clean, and another portion of the sediment taken, and dealt with in the same way. or, if good, after being dried, may be mounted in Canada balsam. The *guano*, from containing a large amount of animal matter, requires a rather different mode of treatment. Mr. Henry Deane, of Clapham, who has paid considerable attention to these matters, has recommended the following as the best method of proceeding:—“Take any convenient quantity of pure Ichaboe guano, and wash it by repeated ablutions of distilled water, until the water is no longer coloured, observing after each addition of water, that it must be well stirred two or three times, and then allowed to settle for some hours. When sufficiently washed, a small quantity of hydrochloric acid is to be added to the water last used: this dissolves some portion of it with effervescence, and causes a more perfect subsidence of that portion which it does not act upon. After this, allow sufficient time for the deposit to become well settled down; then, the clear liquor being poured off as clearly as possible without loss of the sediment, a quantity of strong nitric acid, in the proportion of about two fluid ounces to every ounce by weight of guano employed, is to be added. A strong effervescence takes place, which is to be assisted by setting the mixture in a warm place, at the temperature of about 200°, for six hours, during which time the greater part of the guano is dissolved. After allowing it to stand in a cold place for twenty-four hours, pour off the acid liquor as closely

* *Transactions of the Microscopical Society*, Vol. ii.

as possible, and wash the sediment with an abundance of distilled water. The finer portions of this sediment will contain all the siliceous shells of the guano, perfectly freed from extraneous matter." It should be borne in mind, in all these cases, that some time should elapse before the acids or the distilled water are poured off from the sediment, in order that the solid matters may subside, as it has often happened that the most beautiful of the infusoria have been thrown away with the water employed to wash them.

CHAPTER XVIII.

CLASSIFICATION OF THE MOST IMPORTANT MICROSCOPICAL OBJECTS.

FOR the advantage of those who are resident in the country, as well as for those who may be desirous of investigating any of the various branches of natural history, whether for amusement or otherwise, it has been deemed advisable to divide vegetable and animal structures into different classes. Mr. Topping, of No. 1, York-place, New-road, Pentonville, one of our most ingenious preparers of microscopic objects, has obligingly furnished the author with a list of the most important specimens of the various classes which he is in the habit of supplying to his customers; from this, as well as from one which has been derived from a variety of other sources, including the author's own experience, the following collection of the most interesting subjects for examination has been drawn up. Those who may require a more extended list, may consult a work published in 1847, entitled *Microscopic Objects*; also a *List of Two Thousand Microscopic Objects*, by A. Pritchard. London, 1835. A full description of the vegetable and animal tissues will also be given in a catalogue of the microscopical preparations shortly to be published by the Royal College of Surgeons. As the structure of vegetables is more

easily made out than that of animals, and much less dissection and preparation required in the former than in the latter, the author has thought proper to commence the classification with a few of the most characteristic objects that can be procured from the vegetable kingdom, as illustrations of structural botany.

VEGETABLE TISSUES.

Preparations of vegetable tissues are principally obtained either by tearing, by making sections, by maceration, or by dissection, whilst others can be examined in the natural state.

Cuticles.—The cuticle of the stem, flower, or leaves, may be removed in the manner described at page 324, by taking a small portion between the blade of the knife and the thumb, and tearing it away in the direction in which the separation is most easily effected. Cuticles should be mounted either dry or in fluid; when much colouring matter is present, the former method, or that in balsam, should be adopted. A few of the most illustrative specimens may be obtained from the following plants:—

Pelargonium,	Deutzia,	Oncidium,
Geranium,	Nepenthes,	Opuntia vulgaris,
Anagallis,	Oleander,	Agave Americana.

Cellular Tissue.—This tissue enters more largely than any other into the composition of vegetable structures; it may be obtained very readily from ripe pulpy fruits, such as the strawberry, raspberry, and peach; from other plants it may be procured by maceration, or the shape of the individual cells may be shown by vertical and horizontal sections. The following list will embrace some of the most interesting varieties:—

Sections of Pith of Elder,	Pulp of Peach,
———— Filix mas,	———— Orange,
———— Liliun candidum(leaf),	Hair of Tradescantia,
———— Rice paper plant,	———— Groundsel,
Pulp of Strawberry,	———— Cotton plant,
———— Raspberry,	———— Pentstemon.

Fibro-cellular Tissue.—This very elegant tissue, consisting of a cell, in the interior of which a spiral fibre is coiled up, is found readily in a moss termed Sphagnum, or bog moss; but in some of the orchidaceous plants, the leaves are almost entirely made up of it, from which the cells may be obtained either by maceration or by section; the best examples are afforded by the following plants:—

Sphagnum, Cobæa scandens, Pleurothallis angustifolia.

A modification of this form of tissue is found in the testa of some seeds; a portion of it from the following seeds, when wetted, will exhibit both the cell and the fibre in a very beautiful manner:—

Salvia, Collomia grandifolia, Collomia linearis, Acanthodium.

In the Elaters of Jungermannia a similar kind of tissue may also be seen.

Spiral Vessels.—These may be procured either by maceration and subsequent dissection, or by vertical sections of the stems of plants; in some transparent leaves they may be seen in situ, or may be accidentally separated with the cuticle. Very good examples will be found in the following plants:—

Cactus speciosa,	Amadou,	Long Leek,
Cactus opuntia,	Hyacinth,	Lycopodium,
Rhubarb,	Nepenthes,	Canna bicolor,
Mexican Lily,	Asparagus,	Palm.

Ducts of various kinds.—These, like spiral vessels, may be dissected out of soft stems or roots after maceration, or may be examined by vertical and horizontal sections of more dense structures; the following plants will exhibit some of the most interesting specimens:—

Pteris aquilina,	Elaterium,	Phoenix dactylifera,
Rhubarb,	Dahlia,	Opuntia vulgaris.

Woody Fibre.—This, although strictly cellular, is much more firm and elastic than the usual forms of that tissue; the walls of the cells are for the most part structureless, whilst others are covered with minute markings, or with glands, as, for example, in the coniferous tribe. The cells of woody fibre

may be examined in vertical and horizontal sections; and after long maceration, or by a process termed *hackling*, as in the case of flax and hemp, may be separated from other investing tissues. In the latter plants it may be seen in its most simple condition, whilst, in sections, all its peculiar modifications can be examined; the subjoined list will afford some of the most characteristic examples:—

Flax,	Sections of Araucaria excelsa,
Flax, New Zealand,	———— Ephedra,
China grass,	———— Date palm,
Hemp,	———— Drimys Winteri,
Sections of Pine,	———— Nipal wood,
———— Yew,	———— Cedar.

The following list of sections of wood, made by Mr. Topping, in three different directions, as described in page 311, will also serve to illustrate the structure and arrangement of the more important tissues, viz.:—

Oak,	Elm,	Dragon palm,
Yew,	Willow,	China rice-paper,
Scotch fir,	Poplar,	Indian ditto,
Weymouth Pine,	Date palm,	Pith of elder,
Pine,	Cane,	Root of gooseberry.
Norfolk Island ditto,	Dragon-cane,	———— sycamore,
Malogany,	Malacca-cane,	———— furze,
Cobæa scandens,	Wanghee-cane,	———— vine,
Alder,	Bamboo,	———— mimosa,
Grape-vine,	Sugar-cane,	———— elder,
Line-tree	Rush,	———— elm,
Cedar,	Equisetum,	———— oak,
Cork,	Pteris aquilina,	———— apple.

Fossil Woods.—Sections of these, made by the lapidary in the same direction as the woods last described, will exhibit very remarkable structures, the woody fibres, and sometimes the vessels, being as perfect in them as in any recent stems. Specimens obtained from the following localities will be found amongst the most striking of this class of objects:—

Endogens . . East Indies,	Exogens . . Harwich,
" Antigua.	" Honduras,
Exogens . . Antigua,	" Isle of Wight,
" Allen Bank,	" Lenel Braes,
" Australia,	" New Holland,
" Craigleith,	" Oldburg,
" Claycross, Derbyshire,	" Tweed Mill,
" Cromer,	" Warwick,
" Dudley,	" Van Dieman's Land,
" Darleston,	&c. &c.
" Egypt,	

Siliceous Cuticles.—These, obtained from the following stems and parts of grasses, in the manner before described at page 305, by the action of acid, will exhibit the beautiful arrangement of silica so constant in this tribe of plants, and which forms so splendid an object for polarized light:—

Equisetum,	Oat-straw,	Rye,
Wheat-straw,	Oat,	Malacca-cane,
Wheat,	Canary-straw,	Dragon-cane,
Barley-straw,	Canary-seed,	Wanghee-cane,
Barley,	Rye-straw,	Bamboo-cane.

With the above list may be included the following one, which consists of the hairs of certain plants, these, like the cuticles above described, are provided with a protecting coat of silica:—

Leaf of Deutzia, Durio, Elæagnus, Olive.

Hairs.—These are found principally upon the under surfaces of leaves, upon stems, or upon some part of the flower; they are generally viewed as opaque objects; some of the larger kinds may be detached, and then mounted either in fluid or in Canada balsam. The following list will exhibit a few of the most interesting varieties:—

Leaf of Deutzia,	Borago officinalis,	Durio zebethinus,
Anchusa tinctoria,	Dolichos pruriens,	Nepenthes,
——— angustifolia,	Elæagnus angustifolia,	Dorstenia,
Althæa,	Acanthodium,	Verbascum.

Pollen.—All the darker kinds may be mounted in Canada

balsam, the more transparent either in fluid or dry; some remarkable examples will be found in the subjoined list:—

Acacia armata,	Fuchsia globosa,	Marvel of Peru,
Anagallis arvensis,	Geranium Robertianum,	Polygonum orientale,
Calla Æthiopica,	Guernsey-lily,	Pentstemon,
Campanula,	Iris fœtidissima,	Sedum acre,
Convolvulus major,	Jasmine,	Tiger-lily,
————— minor,	Lychnis, scarlet,	Tulip.

Starch.—The granules of starch are obtained from a variety of plants by repeated washing in cold water; many kinds are sold, but that from wheat, rice, arrow-root, potato, and tous les mois (Canna), are amongst the most common; the specimens should be mounted dry, in a very thin glass cell, or in one made of paper, so as to keep the cover from pressing too much on the granules. A knowledge of the appearance of the different kinds of starch, when examined by the microscope, is of great importance in detecting the frauds often practised on the public by introducing granules of a common kind, and puffing them off as belonging to another and more expensive plant; they are also very beautiful objects when examined by polarized light. The following list will give the most interesting varieties:—

Arrow-root,	Indian-corn,	Sago,
Ditto, East Indian,	Iceland-moss,	Tapioca,
Ditto, West Indian,	Potato,	Tous les mois (Canna),
Bright's custard-powder,	Rice,	Wheat.

Seeds.—These are generally examined as opaque objects, with a low magnifying power; some from the orchis tribe, and those that are termed by botanists "*winged*," may be mounted in Canada balsam, and viewed as transparent objects. The following list will contain the names of the most striking specimens:—

Anagallis,	Dandelion,	Orchis maculata,
Anethum,	Eremocarpus,	———— bifolia,
———— graveolens,	Groundsel,	Poppy,
Carroway,	Lupin, blue,	Sorrel,
Carrot,	Lychnis, scarlet,	Sycamore,
Collomia grandiflora,	Mignonette,	Verbena.

Ferns.—The parts of this curious tribe of plants most interesting for microscopic examination, are the reproductive organs or *sporangia* that are situated on the under surface of the fronds; they consist of yellowish brown masses of capsules, in which the seeds or spores are contained. Ferns should be gathered before the capsules are quite ripe, otherwise, in drying, these delicate structures are apt to burst, and the contained spores are scattered to some distance by the action of an elastic spiral spring, which forms a band or zone on the upper part of each capsule. After having been carefully dried, small portions of the frond containing the sporules should be fastened by some cement to any of the large discs before described at page 290, or the very flat kinds may be mounted between glasses with Canada balsam. The capsules are best examined as opaque objects, with a power varying from forty to one hundred diameters, when illuminated by a Lieberkuhn, or by the side reflector. As almost every kind of fern, whether British or foreign, is more or less beautiful, it would be needless to particularize any individual specimens; those, however, presently to be enumerated under the head of spores, will serve to show both the capsules and their contents.

Spores.—These, which are analogous to seeds in other plants, should be examined either as opaque or as transparent objects; with a magnifying power from two hundred to three hundred diameters; the list might well include the whole of the fern tribe, as all are more or less beautiful, but the following may serve as a guide to some of the most interesting specimens:—

Adiantum nigrum,	Lomaria spicant,
—— capillus veneris,	Lycopodium,
Aspidium aculeatum,	Pteris elegans,
Davallia Canariensis,	—— hastata,
Grammitis ceterach,	Polypodium vulgare,
Hymenophyllum Tunbridgense,	Scolopendrium vulgare,
—— Wilsoni,	Todea Africana.

Raphides.—These are crystalline bodies found in the interior of plants; sometimes they resemble needles in shape

(hence their name), at other times they occur in octohedrons, or in stellate bundles. Several varieties will be found in the following list:—

Aloe,	Hickory,	Rhubarb, Turkey,
Apple-tree,	Hyacinth,	———— English,
Cactus opuntia,	Lime bark,	Squill,
Grape vine,	Onion,	Tulip.

Hard Tissues.—These require to be prepared like sections of bone and shell, sometimes by the cutting-machine, but more frequently by grinding down on a hone thin slices that have been cut by a saw; a peculiar kind of gritty tissue is found in the pear tribe—this can be obtained either by sections or by maceration. The following list will embrace the names of some of the most interesting kinds:—

Pear,	Stone of tamarind.
Stone of apricot,	Shells of Brazil-nut,
———— cherry,	———— cocoa-nut,
———— damson,	———— hazel-nut,
———— date,	———— ivory-nut,
———— peach,	———— walnut,
———— plum,	Cone of Pine.

Mosses.—Next to ferns, the structure of mosses is one of extreme interest; the parts most frequently examined are the leaves and the theca, or seed vessel, with its various appendages, viz., teeth, calyptra and operculum. Some specimens may be mounted in Canada balsam after having been moistened, and then properly laid out between sheets of blotting paper, to dry the thecæ; others, from which the operculum has been removed, may be mounted on discs in the manner shown by figs. 195-6-7; and one specimen in particular, named the *Funaria hygrometrica*, when so mounted, will exhibit the movement of the teeth, if the moist breath be allowed to come in contact with them. The leaves of *Sphagnum*, or the bog-moss, exhibit a cellular structure, with a spiral fibre wound round the interior of each cell. The leaves of some species of *Splachnum* and *Hookeria* are also remarkable for the elegance of their appearance. The following genera will be found to include the most interesting varieties:—

Bryum,	Hookeria,	Sphagnum,
Dicranum,	Hypnum,	Tortula,
Funaria,	Orthotrichum,	Trichostomum,
Gymnostomum,	Polytrichum,	Weissia.

Algæ.—These are found abundantly both in salt and fresh water; many of them form most interesting subjects for microscopic examination, the marine species in particular, being so often covered with Zoophytes of various kinds, the ciliated arms and internal structure of whose polyps are objects of such extreme interest. In a work like the present, it would be impossible to point out all the principal varieties in either class; the author would, therefore, beg to refer those who may be anxious to obtain correct information on these subjects, to the excellent work of the Hon. W. H. Harvey, termed *Phycologia Britannica, or a History of British Sea-weeds*; and to the *British Fresh-water Algæ* of A. H. Hassall, Esq.

Miscellaneous Structures of a fibrous character.—For the sake of comparison of known with unknown vegetable and animal fabrics, certain specimens of woody fibre, in the shape of flax, hemp, or cotton, and of animal structures, such as silk, hair, and wool, should be provided; some of them may be examined as opaque objects upon a dark ground, whilst others will require to be viewed by transmitted light. Mummy cloths of different kinds, have often been matters of dispute with various microscopists as to the true nature of the material of which they were composed. Dr. Ure first directed attention to the value of the microscope in these researches, and demonstrated clearly that the material employed by the Egyptians was linen, and by the Peruvians cotton; the former being known by its solid and cylindrical character, the latter by being a more or less flattened band. The structure of silk and hair are widely different from that of cotton or linen, hence, in woven fabrics, a knowledge of each becomes of the greatest importance, as it can be unequivocally demonstrated, by the microscope, whether any of the vegetable matters have been fraudulently introduced with those of an animal nature. The most instructive specimens will be found in the following list:—

Flax,	Cotton-grass,	Mummy cloth, Egyptian,
New Zealand flax,	China grass,	Mummy cloth, Peruvian,
Hemp,	Cotton, raw,	Cloth, Tahitan,
Indian hemp,	Cotton, carded,	Cloth, Sandwich Islands,
Cambric,	Gun-cotton,	Beavers'-hair and wool,
Raw silk,	Muslin,	Rabbits'-hair and wool,
Spun silk,	Wool, sheep,	Goats'-hair and wool,
Silk ribbon,	Cloth,	Byssus of a Pinna,
Lace-tree-bark,	Felt,	————— Mussel.

ANIMAL TISSUES.

Preparations of animal structures are obtained in a variety of ways ; but, more or less, dissection will be found necessary in almost every case. The subjoined lists will afford a few of the best examples of the different kinds that may be procured from the various classes of animals.

Sliceous Skeletons of recent and fossil Infusoria.—These may be obtained from a variety of sources, and as they are capable of resisting the action of strong acids, the method described at page 364 will be found necessary in all cases. They may be mounted in balsam or in fluid ; the very delicate kinds for test objects are, however, generally mounted dry. The following are the localities in which the most remarkable species have been found :—

RECENT INFUSORIA.

America, seven localities,	Ponds at Wandsworth,
Algoa Bay,	„ Totteridge,
Thames, at Tilbury,	„ Hampstead,
„ Woolwich,	„ Highgate,
„ Lambeth,	„ St. John's, New Brun-
Southampton.	„ St. Vincent's, [wick,
—————	„ Petersberg,
Rivers—Tyne,	„ Spring Dyke, Hull.
„ Clyde,	—————
„ Humber,	Ipswich Harbour,
„ Tagus,	Charleston Harbour.
„ Nile,	—————
„ Mersey,	Guano from Ichaboe,
„ Orwell,	„ Peru,
„ Indus,	„ Patagonia,
„ Lea, Essex,	„ Saldanha Bay.
„ New River, Enfield.	

FOSSIL INFUSORIA.

Localities :—

Barbadoes, Mount Hilloughby,
 ——— Springfield,
 Bermuda,
 Franzenbad, Bohemia,
 Bilin (six varieties),
 Upper Bann, Ireland,
 Ireland, Morn-mountain,
 Lapland,
 Eisen (three varieties),
 Richmond, North America,
 Blue-hill-pond, Maine,
 Petersberg, Virginia,
 Piscataway, Maryland,
 Hollis-cliff, Virginia,
 Rappenhanock-cliff, America,
 Oregon,
 Cumberland, Rhode Island,
 Wreatham,
 Kritchelberg,

Localities :—

Holderness, Yorkshire,
 Lunenberg,
 Leicestershire,
 Germany (five varieties),
 Dolgelly, North Wales,
 Bridgewater, America,
 West Point, New York,
 Tuscany (two varieties),
 Jutland State,
 St. Fiora,
 New Zealand,
 Tripoli (two varieties),
 Tuscany,
 Nova Scotia,
 ———
 Mountain Meal,
 ——— Milk,
 Polythalamia, America.

Many other kinds of infusoria may be preserved as microscopic objects, whose bodies are either soft or contain only a small trace of silica; they may be mounted in one of the preservative fluids before described at page 270, but of these the Glycerine appears to preserve the colour best, although the fluids recommended by Mr. Thwaites and Mr. Ralfs will answer for most purposes. The cell to be employed should be very thin, either made of the finest glass, or of gold-size, in the manner recommended by Mr. Topping, in page 257; the cover also should be very thin, as high powers will often be required for their examination. Many species of the following genera may be preserved in fluid, and some of them even in Canada balsam.

In the list will be found several genera, for splendid specimens of which English microscopists are indebted to a few fellow-labourers in America, but more especially to Professor Bailey, of West Point :—

Achnanthes,	Enchelys,	Navicula,
Actinocyclus,	Euastrum,	Paramecium,
Arthrodesmus,	Euglena,	Pyxidicula,
Bacillaria,	Fragillaria,	Stentor,
Brachionus,	Gallionella,	Synedra,
Closterium,	Gomphonema,	Trichoda,
Cocconema,	Gonium,	Vibrio,
Coscinodiscus,	Hydatina,	Volvox,
Doxococcus,	Meridion,	Xanthidium.

Sponges.—These lowly organized animals are found both in salt and fresh water in all parts of the globe, many of them are very minute, and may be examined without much previous preparation, whilst others require either to be burnt or acted on by acid, in order to display the small masses of flint termed *spicula*, which form their rudimentary skeleton, as well as other masses of the same material, which enter largely into the frame-work of the young sponges or *gemmules*. The British fresh water sponges abound frequently in *gemmules*, but the *spicula* are mostly needle-shaped, like the raphides in the hyacinth and squill; in some of the marine species, especially those from Australia, New Zealand, and Algoa-bay, most remarkable specimens of both may be obtained. Mr. Bowerbank, who has paid considerable attention to their microscopic structure, has discovered a variety of new and interesting forms; but as an immense number of foreign species, which possess beautiful *spicula* and *gemmules*, are still undescribed, it would be impossible, at present, to give the names of more than a few of the well known genera:—

Geodia Mulleri,	Spongilla fluviatilis,
Halichondria panicea,	Tethea cranium,
Pachymatisma Johnstoniana,	—— lyncurium.

Mr. Topping informs the author that he is in the habit of supplying no less than eleven varieties of *spicula*, and seven varieties of *gemmules*; also one specimen of siliceous sponge, and five different kinds of sponges in flint, together with moss, agates, and sections of flints from the chalk and gravel.

Alcyonium.—Nearly allied to sponges is a family of Zoophytes, termed Alcyonidæ, which are often lobed in a peculiar manner, the outer skin being tough and studded all

over with stellate figures, each of which is divided into eight rays, from these the tentacula of the polypes, also eight in number, may often be seen to issue. The cells for the polypes are situated immediately under the skin, and are the terminations of long aquiferous canals, which run through the whole polypidom; the space between the tubes is occupied by a loose, fibrous net-work, the fibres of which, in some places, are more crowded than in others, and there form small compartments. All the interspaces are filled up with a transparent gelatine, in which numerous crystalline irregular spicula lie immersed. These spicula are calcareous, and are mostly in the form of a cross, and toothed on the sides.* They may be obtained from thin slices by maceration, or by burning a small portion of the animal in a spirit lamp. Three kinds found on the British coasts are admirably described in the work just quoted; these will all exhibit remarkable spicula, and are named as follows:—

Alcyonium digitatum, *A. glomeratum*, *Sarcodictyon catenata*.

Many other kinds are met with on foreign shores, in which spicula of very peculiar shapes are abundant; the author has in his possession some sea-sand from Java, of which full one-third of the bulk is composed of the spicula of different species of *Alcyonium*, *Gorgonia*, and sponges, and one-third of the remainder of foraminiferous shells.

Gorgonia.—Allied to *Alcyonium* is another family of Zoophytes, termed *Gorgoniadæ*, which, like the preceding, abound in spicula of various shapes; these may be obtained in a similar manner, either by sections, by maceration, or by burning. The British species, according to Dr. Johnston, are five or six in number; but in other parts of the globe they are very abundant. Mr. Topping supplies as many as seventeen varieties of spicula, almost all of which are obtained from foreign specimens. They are often of a beautiful pink colour, and when mounted in Canada balsam, are objects of great

* *A History of British Zoophytes*, by G. Johnston, M.D., LL.D. London, 1847.

interest. The following species are inhabitants of the British seas:—

Gorgonia verrucosa ; G. pinnata ; G. Placonius ; G. anceps ;
Primnoa lepadifera.

Corals.—These are best examined by horizontal and vertical sections ; if the animal matter only is required, the sections may be macerated in hydrochloric acid, to which five or six times its bulk of water has been added. Mr. Bowerbank has paid considerable attention to the structure of the Corallidæ, and to his published paper in the volume of the *Philosophical Transactions* for 1842, the author would refer those who are anxious for information on these points.

Zoophytes.—Residents, or occasional visitors at the sea-side, when provided with a microscope, will have abundant opportunities of examining some of these most elegant of animal forms. Scarcely a piece of sea-weed or fragment of shell will be found, that does not afford a habitation for some member of this interesting family. Some choose for their dwelling-place the depths of the ocean, whilst others are found in localities that are left high and dry at every ebb tide. The inhabitants of the deep water are procured by an operation termed *dredging*, whilst the others can be very well collected at low water, as they are generally adherent to sea-weeds, or to old shells or pebbles ; amongst the most common are the various species of Plumularia, Sertularia, Tubularia, and Bowerbankia, all of which are most beautiful objects for microscopic observation ; the latter genus was especially abundant at Herne Bay, in September, 1848, where it might be picked up in profusion on the beach, being attached to a variety of sea-weeds. For a full description of the various British species of Zoophytes which may be met with either in fresh or salt water, the excellent work of Dr. Johnston, before quoted, should be consulted.

Insects.—This division of the animal kingdom affords to the microscopist the most numerous and, perhaps, the most beautiful class of objects for examination, as there is scarcely a part of the body of an insect that does not exhibit some remarkable

structure. In the following classified list are enumerated some of the insects in which certain parts and organs may best be viewed:—

Antennæ.

Cockchafer,	Gnat,	Staphylinus,
Cockroach,	Midge-fly,	Tiger-moth.

Eggs.

Blow-fly,	Field Cricket,	Privet-moth,
Cabbage-butterfly,	Lacquey-moth,	Spider,
Cockroach,	Magpie-moth,	Water-scorpion.

Elytra.

Buprestis,	Dermestes,	Musk-beetle,
Cockchafer,	Diamond-beetle,	Notonecta,
Cicindela germanica,	Dyticus,	Rose-beetle,
————maritima,	Mantis,	Unicorn-beetle.

The elytra of the various kinds of diamond beetles are amongst the most brilliant of all opaque objects; some of them are much improved by being mounted in a thick cell with Canada balsam, in the manner described at page 280, whilst others lose much of their splendour by being so treated. In order to ascertain whether an elytron will be improved by the balsam, one of the legs, or some part supplied with a few of the iridescent scales, should be touched with turpentine; if the brilliancy be increased, the mounting in Balsam should be adopted; if, on the contrary, the colours be at all deadened, it should be mounted dry, either on a disc or in a cell, as described at page 293. The elytra of some beetles, after having been softened in caustic potash, may be mounted between flat glasses, as ordinary objects, as in them the arrangement of the tracheæ, the pits, and elevations on the surface, and the short spiny, or branched hairs, may be well examined.

Eyes of Insects, Arachnida, and Crustacea.—These differ in very many points from the same organs in the higher classes of animals, each eye being composed of an aggregation of many hundreds of minute lenses into a single group; in the

majority of insects this holds good, but in spiders each eye has only a single lens, and in order to compensate for this seeming want, the number of eyes is increased from four even to twelve in some species; a few genera of insects are provided with two or three single eyes in the front of their heads. The shape of the lenses is always such as to admit of being adapted to each other without loss of space; the more common form is hexagonal, but in some crustacea they are square. The external form of the eye may be seen in situ in all insects when viewed as opaque objects, but the layer of lenses requires the aid of maceration and dissection to free them from a considerable amount of pigment; these may be mounted either dry, in fluid, or in balsam; in the latter way the collection of lenses, if required to be flat, must be made so whilst soft, by pressure, otherwise they are liable to split.

The subjoined list will serve to point out some of the most striking specimens:—

Bee,	Cricket,	Shrimp,
Boat-fly,	Dragon-fly,	Sphinx ligustri,
Butterfly,	Drone-fly,	Spider,
Cicindela,	House-fly,	Stag-beetle,
Cray-fish,	Lobster,	Water-scorpion.

Feet of Insects, &c.—These may be examined as opaque objects when mounted on discs, or by transmitted light when placed in fluid or in Canada balsam; the latter method is, perhaps, on the whole, the most satisfactory. Remarkable examples of adaptation of structure to particular purposes will be found in the following list:—

Blow-fly,	Asilus,	Diamond-beetle,
House-fly,	Bee,	Dyticus marginalis, male,
Drone-fly,	Wasp,	Acilius sulcatus, male,
Saw-fly,	Spider,	Chrysis ignita.

Hairs of Insects, &c.—These may be mounted either in fluid or in the dry way; in some spiders the hairs are branched; in the larvæ of many insects they are covered with spines, and in the crustacea they are provided either with spines, or are plumed very like a feather; some of the most interesting

specimens of the latter kind will be found upon the body and legs of all the crab tribe; but upon the flabella or sweeping organs, which are situated within the branchial chamber, the hairs present the greatest number of peculiarities; they are mostly scimeter shaped, and provided with teeth-like projections from the convex side, for the purpose of separating the laminae of the branchiae one from the other, in order to admit water between them.* The remarkable structure exhibited in the minute hairs of the larva of the *Dermestes* is shown at C, fig. 1, 2, 3, in plate 5; this, in the early days of achromatic microscopes, was considered as a "test object," and on this account has been retained and accurately represented. The most interesting specimens are mentioned in the subjoined list:—

Acilius sulcatus,	<i>Dermestes</i> larva,	Lobster, flabella,
Bee,	Diamond beetle, leg,	——— tail,
Crab, claws,	Gnat, wing,	Sea-mouse,
—— flabella,	Hercules beetle,	Shrimp,
Crab (small edible),	Larva, Tiger-moth,	Spider,
——— flabella,	——— Tussock-moth,	Stag-beetle.

Parts about the Mouth of Insects, &c.—Some of these, such as the jaws of beetles and spiders, and the probosces of the Curculionidæ, require little or no preparation, and may be mounted on discs and examined as opaque objects, whilst others, such as the probosces and lancets of flies and bees, will demand no small amount of skill, in order to display them to the best advantage; when thin and transparent, they should be mounted in fluid, but in balsam when they are thick and opaque. Previous to being mounted in the latter way, all specimens of the proboscis or lancets should be dissected whilst soft, and then laid out in a proper position upon a slide to dry; as those that are taken from recent insects and placed in balsam immediately, generally make it appear milky. The list given below will contain the names of some of the most important varieties:—

* Vide a paper by the author, "On the Structure and Use of the Flabella," in Vol. ii. of the *Transactions of the Microscopical Society*.

Ant,	Cricket,	Proboscis-Butterfly,
Asilus-fly,	Empis-fly,	Rhingia,
Bee,	Flea,	Saw-fly,
Blow-fly,	Gnat,	Scorpion-fly,
Boat-fly,	Hornet,	Spider,
Bug,	House-fly,	Tabanus,
Chameleon-fly,	Ixodes,	Tick,
Cicada,	Proboscis-Moth,	Wasp.

Parasitic Insects.—These, when caught, should be placed in spirit and water, in order to kill them; those that are very transparent may be mounted in fluid, the glycerine or Goadby's solution will answer well; some persons, however, prefer castor-oil for the same purpose. If the specimens be very opaque, they may be dried and mounted in Canada balsam; some of the large kinds, such as the various species of *Ixodes*, with peculiar instruments for adhering to the skin, may be mounted on discs, and examined as opaque objects. The term *Epizoa* has been applied to this class of insects, in consequence of their being found on the exterior of animals, and in contradistinction to those occurring within, which are called *Entozoa*. The species of the former are exceedingly numerous, and but few hitherto have been described, scarcely any animal of the higher classes is free from them during some part or other of its existence. The subjoined list could be carried on almost *ad infinitum*, but it has been deemed necessary only to include in it such specimens as exhibit some interesting points of structure. Those who would wish to see figures and descriptions of a great number of species, should consult the *Anoplurorum* of Mr. Denny, a work devoted especially to the subject.* Some of the parasites are claimed by the entomologist as belonging to the class *Insecta*, which includes all that have six legs, whilst others, having eight, and commonly termed *Acari*, are included in another class termed *Arachnida*. In the present case such a distinction is not necessary; they will, therefore, all be termed Parasites or *Epizoa*, and placed in alphabetical order:—

* *Monographia Anoplurorum Britanniae*, by H. Denny. London, 1842.

Albatross,	Flea, Hedgehog,	Rabbit,
Boa,	— Mole,	Rook,
Bug,	Guinea-pig,	Snail,
— exuvia of,	Horse,	Snake,
Cariama,	Harvest-bug,	Stork,
Cat,	Ornithorhynchus,	Swallow,
Dog,	Partridge,	Tick of dog,
Eagle,	Peacock,	— ox,
Flea, Bat,	Pediculi humani,	— polecat,
— Bed,	Pig,	— sheep,
— Cat,	Pigeon,	Vulture,
— Dog,	Pheasant,	Water-rat.

Some very minute insects, termed *Aphides*, are abundant on most plants, the leaves of which they speedily injure and destroy; others again, to which the term *Cynips* has been assigned, are the cause of certain excrescences on the leaves of plants and trees termed galls. The well known oak-apple is produced by an insect termed the *Cynips quercus*, a most exquisite object when examined by reflected light; the same also may be said of the insect from the gall of the rose. In order to collect the *Cynips* from these structures, they should be gathered when ripe, and placed in a box covered with gauze; in a few days or weeks numbers of insects will escape from the gall; from a single oak-apple hundreds have been known to make their appearance, and, perhaps, only one in every six will exhibit beautiful colours, the others being black; these may be rejected, as they exhibit no remarkable structure. The coloured flies from galls of the following trees may be procured very readily, and are amongst the most beautiful of their kind:—

Cynips of the ash,	Aphis of the geranium,
— oak,	— hop,
— rose,	— potato,
— sycamore,	— rose.

Another tribe of minute insects is known by the name of *Acari*; of these the cheese-mite, with its eight legs, is the most familiar example; generally speaking, these burrow into the soft parts, and are only occasionally found on the surface;

one species is found peculiar to the human subject, and others to particular animals. With the Acari may be noticed another parasite occurring in the sebaceous follicles, that in man being called the *Entozoon folliculorum*. The subjoined list will give the names of a few specimens of both kinds:—

Acarus autumnalis (harvest-bug),	Entozoon folliculorum (dog),
—— domesticus (cheese-mite),	————— (horse),
—— scabiei (itch-insect),	————— (man).

Method of obtaining the Acarus scabiei or Itch-insect.—

Many persons having so often failed in procuring the Acari from the disease called *itch*, and those from the little black spots about the face, termed *acne*, have been led to doubt the existence of these minute creatures; on this account it has been deemed necessary to give a few hints how they may be best obtained. In the case of the itch-insect, *Acarus scabiei*, the operator must examine carefully the parts surrounding each pustule, and he will generally find in the early stage of the disease a red spot or line communicating with it; this part, and not the pustule, must be probed, as it were, with a pointed instrument, and the insect, if present, turned out of its lurking place; the operator must not be disappointed by repeated failures, as, in the best marked cases, it is often difficult to detect its haunts; when found, the creature may be mounted in some of the preservative fluids, the glycerine, perhaps, will answer the best.

To obtain the *Entozoon folliculorum*, it is necessary to choose some spot where the sebaceous follicles are very abundant—the forehead, the nose, and the angles between the nose and lips, being the regions that should be selected; if a part where a little black spot or a pustule is seen, be squeezed rather hard, the sebaceous or oily matter accumulated unnaturally will be forced out; if this be laid on a slide, and a small quantity of oil be added to it, so as to separate the harder portions, the insects, in all probability, will be floated out; after the addition of more oil, they may be taken away from the sebaceous matter by means of a fine-pointed sable pencil-brush, and transferred to a clean slide, where they may

be covered over with thin glass, and mounted in the usual manner. The Entozoa are more abundant in the skin of some persons than of others, but there is rarely an instance where many black spots are seen about the face or forehead from which they may not be obtained after a careful search.

Another species of Acarus, termed the *A. autumnalis*, or harvest-bug, is very common in the autumn; these insects crawl on the skin, and insinuate themselves into it at the roots of the hairs, where they occasion a very painful irritation; if these parts be examined, a number of minute red spots will be seen, from each of which a reddish acarus of small size may be dislodged by means of a needle or other sharp-pointed instrument; this can be best seen in fluid, but the structure of the darker kinds may even be satisfactorily made out when mounted in Canada balsam.

Another Acarus, and one which for very many years has been the great source of delight to young observers, is the *A. domesticus*, or cheese mite, this may be well shown either as an opaque or a transparent object; as mites can be so readily met with alive, it is hardly necessary to mount a specimen as an object; if, however, such be required, the glycerine will be found the best fluid for the purpose.

Scales of Insects.—These minute bodies, familiarly known as down, were first discovered and described by Leeuwenhoek; in more modern times, the lines on their surfaces have served as objects for testing the defining powers of single lenses, doublets, and achromatic combinations. The scales having the greatest number of lines in a given space, and, therefore, the most difficult to define, are accurately represented in plates 6 and 7, and a full description of the same will be found under the head of *test objects*. In order to examine them to the greatest advantage, they should be mounted in the dry way after the plans described at page 287, and exhibited by figs. 192-3; the scales are readily removed from the wing by merely pressing the latter very gently upon an ordinary slide, or upon a piece of thin glass, to which they will adhere firmly; they may then be covered up and cemented in the manner previously described for dry objects, or as shown by figs. 192-3.

The scales from the wings and bodies of the following insects will exhibit many varieties of markings, all of which may be employed as *tests* :—

Alucita hexadactyla,	Podura plumbea,
Curculio imperialis,	Polyommatus Arion,
Gnat,	————— Acis,
Hipparchia janira,	————— Adonis,
Lasiocampa quercus,	————— Alexis,
Lepisma saccharina,	————— Argus,
Morpho Menelaus,	————— Argiolus,
Papilio Paris,	Tinea vestianella.

Spiracles and Tracheæ of Insects.—The method of preparing the tracheæ and spiracles of insects has already been described at pages 330-1-2; they may be examined in situ in many of the parasitic insects, in others the aid of dissection is necessary for their due display. It must be borne in mind, that if they be mounted in balsam they show best when full of air. The following larvæ and perfect insects will exhibit the tracheæ and spiracles in a very beautiful manner :—

<i>Spiracles.</i>	<i>Tracheæ.</i>
Bee,	Blow-fly,
Blow-fly,	Centipede,
Centipede,	Chameleon-fly,
Cockchafer,	Larva of cockchafer,
Dyticus,	————— dyticus,
Larva of blow-fly.	————— goat-moth,
Wasp,	————— silkworm.

Stings.—All the apparatus by which the poisonous matter is secreted, and the ducts by which it is conveyed to the sting, as well as the sting itself, are best shown in fluid; but as the dissection of these delicate parts requires such considerable care, the plan of drying, and then mounting them in balsam, is more commonly practised; the subjoined list will point out the best insects for the purpose :—

Bee,	Ichneumon fly,
Hornet,	Wasp.

Stomachs.—In some insects, such as the bee, the ramifications and anastomoses of delicate tracheæ may be shown upon the thin walls of this viscus; in others, the glandular structure of the organ is well seen, whilst, in a few, the triturating apparatus, or gizzard, situated at that part of the junction of the stomach with the intestine, called the pylorus, may be well exhibited. The insects named below will show all these parts to advantage, and are, therefore, the best for dissection:—

Bee,	Cricket (common),	Staphylinus,
Blow-fly,	Mole-cricket,	Stag-beetle,
Cockroach,	Dyticus marginalis,	Wasp.

Besides the parts of insects just given in the classified lists, there are other important organs that require a separate mention, such as the ovipositors of various flies, the spinnerets of spiders, the jaws of the locust, and other orthoptera, together with many remarkable structures that will fall in the way of the minute dissector. The insects in which the ovipositor can be well seen will be here enumerated, as well as some other parts of the same interesting class of animals, that will amply repay a careful examination and dissection:—

Ovipositor of Cicada,	Web of Clubiona atrox,
———— Cynips quercus,	Jaw of locust,
———— drone-fly,	———— house-cricket,
———— field-cricket,	———— mantis,
———— Ichneumon,	Drum of cicada,
———— saw-fly,	File of cricket,
Spinneret of spider,	———— grasshopper.

PREPARATIONS FROM THE HIGHER ANIMALS.

*Blood.**—To examine this vital fluid, it is necessary to place upon a glass slide a small drop recently taken from the

* Those who may wish to learn the comparative sizes of the blood corpuscles in the vertebrate animals, should consult the valuable table of Mr. Gulliver, published in the CLII. Number of the *Proceedings of the Zoological Society*.

animal ; a cover of mica, or of the thinnest glass, should be laid over the drop, which is then ready to be viewed with the highest powers. If it be required to reserve a specimen for future examination, a very small quantity should be spread in the thinnest possible layer upon a glass slide ; this last is then to be passed rapidly backwards and forwards through the air, so as to dry the blood as quickly as possible, when the discs or corpuscles will be found to have altered but little in shape ; in order to prevent the preparation from being injured, or even rubbed off, a cover of the finest glass should be laid over it, and cemented down in the manner described at page 285 ; a specimen so mounted may be kept for years. The following vertebrate animals will exhibit the most marked peculiarities, the corpuscles being largest in reptiles and fishes, and smallest in birds and mammals :—

<i>Fishes.</i>	<i>Reptiles.</i>	<i>Mammals.</i>
Eel,	Crocodile,	Camel,
Perch,	Frog,	Dromedary,
Salmon,	Green lizard,	Elephant,
Skate.	Newt,	Goat,
	Siren,	Hedgehog,
	Slow-worm,	Man,
	Snake,	Mouse,
	Toad,	Napu musk-deer,
	Tortoise.	Sheep,
	Turtle.	Sloth (two-toed).

Bone.—The structure of the osseous skeleton of animals can only be satisfactorily examined by thin sections, made in different directions, and ground down, polished, and mounted, according to the directions given at page 297 ; if, however, it be merely required to view the shape of the bone cells in fossil bones, small thin chippings, mounted in balsam, will suffice. In order to obtain a good general idea of the structure of bone in the vertebrate classes, specimens, cut horizontally and vertically, should be obtained from the following animals :—

Fishes.
 Cod,
 Conger-eel,
 Eel, common,
 Flying-fish,
 Lepidosteus,
 ——— scale,
 Ray (spine),
 Shark (vertebra),
 Silurus (spine),
 Sturgeon,
 Sword-fish (sword),
 Turbot, spine.

Reptiles.
 Boa (vertebra),
 ——— (rib),
 Crocodile,
 Frog,
 Menopome,
 Newt,
 Siren,
 Snake,
 Toad,
 Tortoise,
 Turtle,
 ——— Carapace.

Birds.
 Albatross,
 Common fowl,
 Ostrich, adult,
 ——— young,
 Penguin,
 Swallow.

Mammals.
 Bat,
 Camel,
 Elephant,
 Horse,
 Human, adult,
 ——— fetal,

Lion,
 Mouse,
 Ox,
 Rhinoceros,
 Stag,
 Whale.

Specimens may be taken from the crania of small animals so thin, that they will require no grinding at all; these may either be mounted dry or in fluid; even in larger animals portions of the ethmoid bone will often require no preparation, being sufficiently transparent for all purposes of examination.

Besides the above described specimens of recent bones, there are others found in the fossil state that, when cut and polished, will exhibit their intimate structure as well as the fresh specimens; they are generally prepared in the same manner as the fossil woods before noticed; others, when very opaque, may be entirely mounted in balsam. The subjoined list will afford the names of a few animals in which the most interesting structures may be found:—

Bear,
 Dinornis,
 Elk,
 Hippopotamus,
 Hyæna,

Icthyosaurus,
 Iguanodon,
 Mammoth,
 Mastodon,
 Man,

Plesiosaurus,
 Pterodactyle,
 Rhinoceros,
 Whale—rib,
 ——— ear-bone.

Teeth.—Like bone, these require to be made thin and polished, in the manner described at page 301; but the operation is very difficult, as the majority of teeth are supplied with a coating of enamel of flinty hardness. As there are three distinct elements, viz., the cement, the ivory, and the enamel entering into the formation of most teeth, it will be necessary that the sections be made in many directions, in order to arrive at a true knowledge of the formation of each. In the following list will be given the names of a few of the animals whose teeth exhibit some well marked points of structure :—

<i>Fishes.</i>	<i>Reptiles.</i>	
Cat-fish,	Alligator,	Dugong,
Cod-fish,	Boa,	Elephant,
Conger-eel,	Crocodile,	Fox,
Common eel,	Iguana.	Horse,
Halibut,		Human, adult,
Lepidosteus,	<i>Mammals.</i>	——— foetal,
Myliobates,	Armadillo,	Hyæna,
Parrot-fish,	Ass,	Kangaroo,
Pike,	Bear,	Lion,
Pike-Barracuda,	Beaver,	Mouse,
Shark, Carcharias,	Boar,	Ox,
——— Lamna,	Cat,	Rat,
Saw-fish,	Deer,	Sheep,
Wolf-fish.	Dog,	Tiger,
		Whale.

Fossil Teeth.—These, like the fossil woods and bones before named, may be mounted on slides, with or without being covered with Canada balsam; many of them, however, differ but little from the recent specimens, but those of extinct races of animals exhibit some very remarkable peculiarities, and should, in all cases, be carefully examined, as from the structure of a tooth alone, the class of an animal has more than once been determined. Those who would wish to enter minutely into the examination of recent and fossil teeth, should consult the admirable *Odontography* of Professor Owen. A few interesting specimens of the teeth of different animals are here enumerated :—

Bear,	Icthyosaurus,	Myliobates,
Dendrodus,	Labyrinthodon,	Plesiosaurus,
Hyæna,	Mastodon,	Shark (many species).

Shell.—The structure of shell has only lately attracted the attention of microscopists, but since the year 1842 the subject has been scientifically investigated by Mr. Bowerbank and Dr. Carpenter; to the latter gentleman, more especially, we are indebted for several valuable papers in the *Transactions of the British Association*, to which the author would beg to refer those who may wish to enter fully into the subject. The method of preparing these interesting structures for examination has already been detailed at page 302, it now only remains to give a list of the genera and species that should be selected, in order to exhibit the principal peculiarities in structure, as described by Dr. Carpenter; these are as follow:—

Anatina olen,	Luna scabra,	Pinna marina,
Anomia ephippium,	Lingula anatina,	Pinna nigrina,
Avicula margaritacea,	Malleus albus,	Pinna, fibres of,
Etheria,	Mya arenaria,	Pleurorhynchus,
Gervillia,	Ostrea edulis,	Terebratula,
Haliotis splendens,	Perna ephippium,	Trigonia,
Hippurite,	Pinna squamosa,	Unio occidentis.

Besides the structure of the shells of the molluscous animals before enumerated, there are others belonging to the classes of Echinodermata, Crustacea, and Cephalopoda, that require a separate mention; thin sections of these, in different directions, are prepared in the same manner as those of shell, which they have been said somewhat to resemble in their minute structural arrangements. The most interesting varieties are mentioned in the following list:—

Belemnite,	Cuttle-bone,	Pentacrinite,
Cidaris, spine,	Echinus, spine,	Prawn,
Crab, red part,	——— shell,	Shrimp,
—— black part,	Encrinite,	Spatangus,
Cray-fish,	Lobster,	Star-fish.

The structure of the spines of the *Cidaris*, and many other species of *Echinus*, are some of the most beautiful objects

that have yet been exhibited by the microscope; they are so very brittle, that the greatest care is required in grinding them down; the method described in page 303 for delicate specimens of bone and teeth, should be the one adopted; and to preserve them from injury, and at the same time to display all the peculiarities in their arrangement, they should be mounted in Canada balsam; some of the very minute coloured spines from small species of Echini are interesting subjects for examination when laid flat in balsam, without any previous preparation. Transverse sections are the best for exhibiting the cellular arrangement; the longitudinal do not show much more by the microscope than can be seen by the naked eye.

In all the shell structures, in order to understand the arrangement of the animal matter, one or more sections in each direction should be subjected to the decalcifying process, as described in page 303, the acid employed being the hydrochloric, diluted with forty times its bulk of water.

Scales of Fish.—These dermal appendages may be divided into two classes; first, into those that are made up of a horny material, such as in the salmon and carp; and, secondly, into those whose structure is true bone. The scales of the majority of fishes belong to the first class, but very few species now remain of the second class, almost all are extinct; the *Lepidosteus*, or Bony-pike, of North America, the Sturgeon, and Paddle-fish, being the most familiar examples. A knowledge of the form and structure of scales, like that of teeth, has, by the labours of M. Agassiz, been shown to afford an unerring indication of the particular class to which any fish may belong; in fossil fish, the application of this principle has been attended with extraordinary results. By Agassiz, the scales have been divided into four orders, named *Placoid*, *Ganoid*, *Ctenoid*, and *Cycloid*; in the first two, the scales are more or less coated with enamel, whilst in the others they are of a horny nature. To the *Placoid* order belong the cartilaginous fishes, whose skins are either entirely or partially covered with small prickly or flattened spines, as in the skates, dog-fish, and sharks. Of the *Ganoid* order, once the most numerous, only a few living representatives, such as the *Lepidosteus*, *Polypterus*, and

Sturgeon remain, the others are found in the fossil state alone ; their scales present a true bony structure. The Ctenoid scales are notched like the teeth of a comb on their posterior or attached borders, the perch and basse are excellent examples, whilst to the Cycloid belong those fish whose scales are more or less laminated and circular, the majority of our edible fish, such as the carp, roach, salmon, herring, &c., afford familiar illustrations of this order. The method of mounting scales of various kinds for microscopic examination, is generally in the dry way, either on discs or between glasses, the former method is the best for those to be viewed as opaque objects, the latter as transparent ones. Their structure, however, is best seen in fluid, when many of them will form splendid objects for polarized light, for this purpose they may even be mounted in balsam. Fragments of fossil scales of fish are best prepared in the latter way ; these may generally be obtained from nodules of flint, found in particular localities. According to the author of the work entitled *Microscopic Objects*, "those from the gravel drifts at Gillingham, in Surrey, and the flint nodules in the chalk between Gravesend and Rochester," seldom fail, when broken into flat pieces, to yield an abundant supply. A few of the most striking examples of the four orders will be found in the subjoined list :—

<i>Placoid.</i>	<i>Ganoid.</i>
Dog-fish,	Hassar-fish,
Ray (spine),	Lepidosteus,
— (shagreen),	Polypterus,
Shark, <i>Squalus galeus</i> ,	Sturgeon.
— Hammer-headed,	
— Port Jackson.	<i>Cycloid.</i>
<i>Ctenoid.</i>	Blenny,
Basse,	Carp,
Perch,	Conger-eel,
Pike—Barracuda,	Eel, common,
Pope,	Herring,
Weaver-fish.	Roach,
	Salmon.

The scales of the eel tribe are amongst the most remarkable

that can be selected for microscopic examination; many persons consider that these fish are without scales, in consequence of their being firmly imbedded in a thick epidermal mucus; in order, therefore, to procure them, a sharp knife must be passed underneath the epidermal layer, and a portion of this raised in the same manner as was described for tearing off the cuticle of plants; after some trials a few will be detached; they are of an oval figure, rather softer than the scales of other fishes, and in some parts of the skin do not form a continuous layer. When the skin has been stripped off, previous to the fish being cooked, the scales may be obtained from the under surface, by tearing them away either with a knife or pair of forceps. The scales of the Viviparous Blenny are of a circular figure, and situated under the epidermal layer; they have been described by Mr. Yarrell as mucous glands, in consequence of their figure and the smallness of their numbers. The surface of the skin of this fish, when fresh, appears covered with follicles; if, however, a knife be passed underneath one of these, a delicate circular scale will be removed. A portion of the skin, when dried, will exhibit the scales to great advantage, and, like those of the eel, they form beautiful objects for polarized light.

Hairs.—These are very readily obtained from all the higher animals, their presence even may be detected in the whale tribe when young. The smaller kind of hairs may be mounted either dry or in fluid; when of a dark colour, Canada balsam is to be preferred; to obtain a satisfactory view of the structure of large hairs and spines, horizontal and vertical sections should be made by the machine described at page 307. Previous to being mounted, the hairs should be perfectly cleaned, as more or less greasy matter is always present about them, ether should be employed as the cleansing fluid, the hairs being made dry by pressing them between folds of blotting-paper. Care should be taken to select both the hair and the wool from each animal, as they differ materially in their structure, the finer kind, or what is known as wool, being endued with the property termed *felting*, which property varies in different species of animals, that of the beaver and nutria

possessing it in the highest degree. All hairs are composed of an aggregation of epithelium cells, and the colour depends upon the quantity of pigment deposited in or about each cell; on this account, some of the most delicate have been used as *test objects*, specimens of which are figured in Plate V., and a description of each given in the chapter devoted to that subject. Hair is employed in most cases as a protective coating, in others as an organ of touch, whilst in a still fewer number, when occurring in the shape of spines, it serves the purpose of a weapon of defence; of this latter, the horn of the rhinoceros, the quills of the porcupine, the spines of the Diodons, are familiar examples, they, like scales and feathers, being modifications of the dermal skeleton. The minute structure of the hairs of different species of the same genus or family is so constant, that a practised eye can readily discriminate between them; several valuable papers on this subject have been published by Mr. Busk, in Vols. I. and II. of *The Microscopic Journal*. A list of many remarkable hairs of insects and crustacea has already been given at page 382. The following animals will exhibit the most characteristic specimens that may be obtained from the vertebrate classes:—

Ant-eater,	Human,	Ornithorhynchus,
Bat (various species),	— (fœtal),	Otter,
Bat, Indian,	— (T.S.),	Porcupine (quill),
Beaver,	Mole,	Rabbit,
Dormouse,	Mouse, common,	Rein-deer,
Echidna,	Mouse, shrew,	Seal,
Elephant (T.S.),	Mouse, white,	Squirrel,
Elk,	Musk-deer,	Tiger (whisker),
Hare,	Nutria,	Walrus (whisker),
Hedgehog (spine of),	Opossum,	Water-rat.

In addition to the cuticular appendages above noticed, there are others that, although not strictly belonging to the series of hairs, are, nevertheless, composed like them of a horny material; in this list may be included the various kinds of horns, hoofs, scales, quills, and whalebone; all these will require to be cut into thin transverse and longitudinal sections by the machine; the darker specimens should be mounted in

balsam, the transparent ones, dry; they all exhibit more or less of a cellular structure, and are objects of great beauty when examined under polarized light:—

<i>Horn</i> —Antelope,	<i>Hoof</i> —Rhinoceros,
„ Ibex,	„ Sheep.
„ Ox,	<i>Quill</i> —Cassowary
„ Rhinoceros, African,	„ Duck,
„ Ditto, Indian,	„ Eagle,
„ Sheep.	„ Goose,
<i>Hoof</i> —Ass,	„ Turkey.
„ Camel,	<i>Whalebone</i> —Great whale,
„ Elephant,	„ Piked whale.
„ Horse,	<i>Scales</i> —Pangolin,
„ Ox,	„ Turtle.

Skin.—In order to understand fully the parts which hair and feathers play in the economy of vertebrate animals, it is necessary to become acquainted with the structure termed *skin*, in which they grow. Their purpose, in the majority of cases, is evidently protective; in birds, however, many of the feathers, especially those of the wings and tail, are employed in flight, whilst the spines of the porcupine and hedgehog are weapons of defence, and the whiskers of the tiger, cat, and other carnivora are organs of touch, and as such are endued with both blood-vessels and nerves, which are distributed upon a highly organized pulp, like that of the teeth. In some animals, such as fish, the skin is not very vascular, whilst in the mammalia, and, perhaps, in the human subject, it attains the highest state of organization. The hairs which grow from the skin are developed from the cuticular layer, and are clothed with a horny epidermis; in those skins where the sense of touch is very acute, the hairs are absent, their place being supplied by highly vascular papillæ, which, in some instances, are covered with horny matter, in the shape of nails and hoofs, or are merely invested with a delicate epithelial layer, as in the case of the lips and mouth. The skin performs a function in the animal economy second only in importance to that of the lungs, and for the purpose is supplied with a very rich capillary net-work, and also provided with

two or more sets of glands, one for secreting the perspiratory fluid, the other an unctuous or sebaceous matter, for lubricating the skin itself, which last is poured out generally at the roots of the hairs, hence the anatomy of the skin presents to the microscopist an immense field for diligent investigation. Taking the human skin as an example, we should commence the study with vertical sections, made through parts supplied both with hair and papillæ; the perspiratory glands are best seen in that of the soles of the feet and palms of the hand; the sebaceous glands, on the contrary, should be examined in parts about the face or chest, where hairs are numerous; these latter sections will also suffice for showing the roots of the hairs, and the hair follicles as well. The capillary net-work of the true skin may be seen in injected specimens when the cuticle has been removed, which will often require the aid of maceration for the purpose; if the skin be that of a black man, care should be taken in the removal of the cuticle, as in it may be examined the *rete mucosum*, or coloured layer, which consists of a series of minute hexagonal cells, containing pigment. The same structure may be seen in the skins of animals whose hairs are black; for this purpose the lips of a black kitten, when injected, should be selected, as in them the mode of growth of the young whiskers, their copious supply of blood-vessels and nerves, and various other points of interest, may be observed. In fishes, the only parts of the skin generally prepared as microscopic objects are those more or less covered with scales, hence may be seen, in various lists of preparations, the skin of the sole and shark; in reptiles, also, we have the skin of the snake, boa, and some lizards, whilst in birds, except when injected, the skin offers but few points worthy of examination besides the feathers. In man and the higher mammalia, the complicated apparatus of glands and papillæ are best examined by vertical sections; but in order to render the skin sufficiently firm for the purpose, it should have been previously hardened in a saturated solution of carbonate of potash, or in strong nitric acid. The hair follicles and sebaceous glands are easily shown, but to display the sudoriferous glands is no easy matter, as rarely will a

specimen of skin be found that will exhibit them and their spiral duct in the whole of its course through the dermal and epidermal layers; it is by far better to try the skins of a number of persons, and select the one that shows them the best, than to waste time by cutting a series of slices from any one specimen. The papillæ are best shown in the extremities of the fingers and toes, when injected; the cuticle which invests them should also be mounted up as an object with its attached or papillary surface uppermost, as in this the grooves for their lodgment, together with the openings of the sudoriferous glands, can be well seen. The following list will include a few of the most important specimens:—

<i>Vertical Sections.</i>		<i>Free Surface.</i>
Ass (corn),	Man (axilla),	Man (face),
Bear (sole of foot),	— (Negro),	— (lips),
Cat (upper lip),	Pig,	— (tips of finger),
Dog (upper lip),	— (snout),	— (cuticle of finger),
Kitten (upper lip),	— (ungual phalanx),	— (back of finger),
Man (sole of foot),	Porpoise (with cuticle),	— (cuticle of finger),
— (palm of hand),	— (without cuticle),	— (Negro),
— (scalp),	Tiger (upper lip),	Newt,
— (face),	— (whisker injected).	— (cuticle).

Eyes.—There are many objects of great interest that may be obtained from the eyes of various animals, especially when injected; amongst these may be enumerated the structure of the crystalline lens, the pigment, the ciliary processes, the retina, and the membrane of Jacob; but as the greater number of specimens cannot be well preserved, so as to show their characteristic peculiarities, the present list will only include those which do not alter by any of the different modes of mounting. The structure of the crystalline lens in fish is best seen after the lens itself has been hardened either by drying, by boiling, or by long maceration in spirit; after having peeled off the outside, the more dense interior will be found to split up into concentric laminae, and each lamina will also be found to be composed of an aggregation of toothed fibres; these are best seen when mounted in fluid, but if dyed, they will show very well in balsam. The pigment is easily

obtained by opening a fresh eye under water, it may then be detached as a separate layer, and portions of it floated on glasses to dry, after which they may be mounted in balsam. The ciliary processes are best seen when injected; they should be mounted in a convenient form of cell, with fluid, and viewed as opaque objects, with a power from thirty to forty diameters. The retina should be examined in a very fresh eye between glasses, and a little serum or aqueous humour added, to allow the parts to be well displayed; but water must be avoided, as the nervous matter will be found to be considerably altered by it; the membrane of Jacob will also require the same precautions to be adopted, but the vascular layer of the retina, when injected, may be well seen after having been dried. The following list will give the names of a few of the eyes from which the most striking specimens may be obtained:—

<i>Ciliary processes.</i>	<i>Crystalline Lens.</i>	<i>Pigment.</i>	<i>Retina.</i>
Cat,	Cod,	Eel,	Eel,
Dog,	Eel,	Frog,	Frog,
Horse,	Herring,	Horse,	Horse,
Ox,	Gold-fish,	Man,	Ox,
Seal,	Sole,	Ox,	Rabbit,
Tiger,	Turbot.	Sheep,	Sheep.

Muscular Fibre.—The mode of preparing this highly interesting tissue has already been given at page 329, it only remains in this place to add a list of the animals from which the most instructive preparations may be procured. The capillary vessels of muscle, as stated at page 330, may be seen in the thin muscles of the eyes of birds and small mammalia, but they are best studied after injection:—

Blow-fly,	Cod,	Fowl,
Cricket,	Eel,	Ostrich,
Dyticus,	Salmon,	Swallow,
Lobster,	Skate,	Deer, Napu Musk,
Shrimp,	Frog,	Elephant,
Oyster,	Newt,	Man,
Snail,	Siren,	Pig,
Terebratula,	Snake,	Whale,

The above list includes only muscular fibres of the striped kind, or what are termed voluntary, in contradistinction to others which are unstriped or involuntary; amongst the latter class, however, are generally mentioned the fibres of the heart in different animals; although these have transverse striæ, the organ itself, nevertheless, is an involuntary one. The muscular coat of the entire alimentary canal, with the exception of the upper part of the œsophagus, is wholly supplied with involuntary fibres, and from any part of the tract specimens may be taken. The fibres, with the exceptions above noticed, differ from those of voluntary muscle, in being much smaller, and also in the absence of striæ. The subjoined list will give the localities of both kinds.

Æsophagus, upper part,	Pleum,
———— middle,	Cæcum,
———— cardiac end,	Rectum,
Stomach, great end,	Heart, human,
———— pylorus,	———— ox,
Duodenum,	———— turtle.

Nearly allied to involuntary muscular fibre, is a fibrous tissue termed the yellow or elastic; this is often found in connection with another finer and less elastic, and called, from its colour, the white fibrous tissue; a mixture of the two is known to anatomists as the areolar tissue, and is largely used in the animal economy; it forms a support for all the vessels, nerves, and muscles, from either of which it may be easily procured; the yellow tissue is found nearly in an isolated condition in the ligamentum nuchæ of the necks of some animals, especially those of the ruminating tribe; it also enters largely into the formation of the intervertebral discs; a portion of the ligament from the neck of the sheep or calf, even after boiling, will exhibit the elastic fibres exceedingly well; they are of nearly uniform size, generally curled at their extremities, and of a yellowish colour. The following animals will show both these tissues to the best advantage:—

Areolar tissue.

Cat,
Dog,
Man,
Rabbit,
Sheep.

Yellow Elastic tissue.

Lig. nuchæ of giraffe,
————— ox,
————— sheep,
Rings of trachea man,
Elastic coat of arteries.

The muscular coat of arteries is composed of a tissue very like the yellow fibrous above described; it may be very easily procured if an artery be cut across transversely, and the central or thickest part selected and separated into as fine fibres as possible by means of the needle-points. If any of the above tissues are required to be kept, they should be mounted in fluid, the spirit and water, or the creosote liquid, will be found to be the most useful for the purpose.

Mucous Membrane.—Continuous with the skin, or outer tegument of the body, is the membrane termed mucous, which forms the investment of all the internal parts, as the skin does of all the external, and is even continued through the ducts of all glands, however complicated, that open upon any part of the surface. This membrane has two surfaces, one free and superficial, the other attached or parenchymal; the former is covered with a layer of particles or cells termed *epithelium*, which, according to their situation, and to the office they perform, are divided into three varieties, the scaly, the prismatic, and the spheroidal; of these, the two last kinds are sometimes provided with vibratile cilia; the latter, or under surface, is supported upon a submucous areolar tissue, in which both the blood vessels and nerves ramify, but do not in any case enter the mucous membrane. Of all the valuable discoveries made by the microscope in minute anatomy, none can at all equal in importance that by which a true knowledge of the structure of the mucous membranes has been obtained, for these very important results we are mainly indebted to the labours of Henle and Bowman; the latter gentleman has divided them into two parts, viz., the basement membrane and epithelium; the name of *basement membrane* has been given to the tissue upon which the epithelium rests, and which forms the basis of the strength and cohesive power that mucous

membrane possesses; in itself it is structureless, but of various degrees of thickness in different parts, and either it or the epithelium is always present where mucous membrane may be said to exist. When the skin is compared accurately with mucous tissue, they will both be found to be parts of one expanded membrane, with certain modifications, according to the office which each is destined to perform; the epithelium of skin is the cuticle or epidermis, but the basement membrane, though present, is not easily shown, except where the surface is raised into papillæ. The mucous membrane, and its three kinds of epithelium, form by far the largest proportion of the preparations which the anatomist will find necessary to examine, and the same, when its capillary system is injected, becomes one of the most beautiful of any of the classes of microscopic objects.

The Epithelium, as has been already stated, consists of three varieties, viz., the scaly, the prismatic, and the spheroidal. The first kind is seen most largely developed in the skin, where it forms the cuticular layer; detached scales may be obtained from the inner side of the mouth, or viewed in situ on the transparent web of the frog's foot, and the entire structure of horns, hairs, hoofs, feathers, and other cuticular appendages is made up of it. The prismatic, or, according to Dr. Todd, the columnar is abundant throughout the stomach and intestines, and even the lungs; each prism is attached end ways to the basement membrane, and is united to its fellows by the sides, so that they form a single layer, the thickness of which depends upon the length of each prism; the attached extremity is generally pointed, the free one wide and flat; this latter, in some parts, is provided with vibratile cilia; the best situation for the examination of these is the villous surface of the small intestine of animals; if the ciliary movement is desired to be viewed, the upper and back part of the Schneiderian membrane, or some portion of the respiratory tract, may be selected, as in these spots the prisms are clothed with cilia, and may be observed in rapid movement some little time even after the death of the animal. The third variety, or *spheroidal*, is to be met with in all glandular structures;

and so constant is its presence in them, that the name of *glandular* has often been applied to it. The parts in which it may be readily examined are the tubes of the stomach and kidney; the secreting structure of the liver is also made up of it. In the two former situations, the basement membrane, upon which the epithelium rests, can be very well seen; but in the liver, where the cells are most abundant, it cannot be detected.

The movement of the cilia was known to the old microscopists, even as far back as the days of Leeuwenhoek, and from that time up to the present has always been viewed with wonder and amazement; it was first discovered in the infusoria, and afterwards in some of the small molluscous animals; in more modern times it has been detected in all the higher classes, up to man himself. Those who would wish to obtain accurate information upon the subject of cilia, should consult the articles "Cilia" and "Mucous Membrane," in the *Cyclopædia of Anatomy and Physiology*.

Method of Viewing the Ciliary Movement.—If the roof of the mouth of a living frog be scraped with the end of a scalpel, and the detached mucous matter placed on a glass slide, and examined with a power of two hundred diameters, the ciliated epithelium cells may be well seen; when a number of these are collected together, the movement is effected with apparent regularity; but in detached scales, it is often so violent, that the scale itself is whirled about in a similar manner to an animalcule provided with a locomotive apparatus of the same description, and has frequently been mistaken for such. The animals more commonly employed for the examination of the cilia are the oyster and the mussel, but the latter is generally preferred. To exhibit the movement to the best advantage, the following method must be adopted:—Open carefully the shells of one of these mollusks, spilling as little as possible of the contained fluid; then, with a pair of fine scissors, remove a small portion of one of the gills (*branchiæ*), lay this on a slide or the tablet of an animalcule cage, and add to it a drop or two of the fluid from the shell, and, by means of the needle-points, separate the filaments one from the other, cover it lightly with

a thin piece of glass, and it is ready for examination. The cilia may then be seen in several rows beating and lashing the water, and producing an infinity of currents in it. If fresh water, instead of that from the shell, be added, the movement will speedily stop, hence the necessity of the caution of preserving the liquid contained in the shell. To observe the action of any one of the cilia, and its form and structure, some hours should be allowed to elapse after the preparation of the filaments above given, the movement then will have become sluggish; if a power of four hundred linear be used, and that part of the cilia attached to the epithelium scale carefully watched, each one will be found to revolve a quarter of a circle, whereby a "feathering movement" is effected,* and a current in one direction constantly produced. In the higher animals, the action of the cilia can only be observed a short time after death. In a nasal polypus, when situated at the upper and back part of the Schneiderian membrane, the cilia may be beautifully seen in rapid action some few hours after its removal; but in the respiratory and other tracts where ciliated epithelium is found, it would be almost impossible ever to see it in action, unless the body were opened immediately after death. In some animals, it may be seen in the interior of the kidney, as was first discovered by Mr. Bowman in the expanded extremity of a tubule surrounding the plexus of blood-vessels forming the so-called Malpighian body; in order to exhibit the ciliary action, the kidney is to have a few very thin slices cut from it, and these are to be moistened with the serum of the blood of the same animal, the vascular and secreting portions of the organ may then be seen with a power of two hundred diameters, and also the cilia in the expanded extremity of each tube, as it passes over to surround the vessels; the epithelium of the tubes themselves is of the spheroidal or glandular character. Since Mr. Bowman's discovery, the phenomenon has been witnessed in other animals in the same situation.

The Basement Membrane, as before described, is structure-

* See a paper by the author, in Vol. II. of *Transactions of the Microscopical Society*.

less, and not supplied in any way with vessels; the best places for viewing it are the tubes of the kidney and stomach, and the villi of the small intestine; in the skin and other smooth surfaces, its presence cannot be so satisfactorily made out. The examination of mucous surfaces and glands, although conducted with great care by some of the earliest microscopists, did not much advance the knowledge of their minute structure, as the instruments employed for the purpose were not suited for very accurate or minute investigation. The principal point arrived at by them was the arrangement of the capillaries, for as long ago as 1736 the art of injecting the minute blood-vessels, which was discovered by De Graaf, in the year 1668, had been brought to such a high state of perfection by Ruysch and Lieberkuhn, that the fame of their productions already extended throughout Europe. But however much anatomists had made out by rough dissection and maceration, it might be said with truth, that nothing beyond the arrangement of the vessels was satisfactorily known until the time of Boehm, Boyd, and Henle; to the latter distinguished anatomist we are chiefly indebted for our knowledge of the structure known as epithelium. By new modes of examination and dissection, as well as by submitting very thin vertical and other sections to the high powers of the achromatic compound microscope, has our present accurate understanding of the structure of mucous membranes and glands been obtained. The methods to be adopted for the examination of mucous membranes in general by the microscope will here be given.

Method of Examining the Surface of Mucous Membranes.—

Supposing, for example, the specimen to be examined be a portion of the mucous membrane of the stomach of an animal recently killed, the surface will be found to be covered over by a thick layer of more or less viscid mucus; this should be got rid of by as gentle means as possible; the best plan, on the whole, perhaps, is that of allowing a small stream of water to flow on it; or, if the specimen be small, it may be pinned out upon one of the loaded corks described at page 321, and well washed by means of the small syringe also described at page

322; if the epithelium be required for examination, a small portion of it may be detached from the surface by a scalpel, placed on a glass slide, and viewed as a transparent object with a power of 200 diameters. But if the mucous membrane itself be required to be examined, it should be done under water, the specimen being pinned out on a loaded cork, and placed in a tin trough with a sufficient quantity of that fluid to cover its entire surface; if necessary, the light of an argand lamp may be condensed upon it; the microscope to be employed for the examination may be one of the kinds shown by figs. 32 and 37; and if the trough be too large to be admitted upon the stage of an ordinary compound instrument, that represented by fig. 216 will be found the most convenient; this method of examination will answer for specimens either injected or not, and should be the one first adopted. In order to obtain a correct idea of the external surface, sections, both horizontal and vertical, should afterwards be taken and submitted to high powers, and when the membrane cannot be well cut into thin slices, it may be separated by the needles, or by moderate pressure in the compressorium. The plan of separation by needles will succeed very well when the tubular portion of the stomach is very thick, as in the case of the porpoise; many tubes may then be detached that could not have been so easily separated by thin sections made with the scalpel. The above described method of examining a mucous membrane, although applied to the stomach, will be found to answer equally well for that of all other parts, not only of the alimentary canal, but all tracts except those in which the epithelium is so abundant, as to form a perfect layer of cuticle; in all these latter cases, it must be needless to mention, that in order to examine the mucous surface, the layer of cuticle must have first been removed; this cannot often be done in the fresh state, the operation of maceration must then be had recourse to for the purpose. If the surface be villous, and have been kept in spirit for some time, it should be pinned out and well washed, either by a stream of water, allowed to run on it, or by a syringe; if the preparation be then allowed to remain in water for a short time, all the villi will float up, and

their shape be ascertained. In modern times the art of injection, which, in this country, had for a long period been neglected, began to be again revived, with the employment of the achromatic microscope; and, by its agency, within the last few years, numerous most interesting discoveries have been made, especially since the invention of thin glass, and the mounting of objects in fluid, and of viewing them in it, have been adopted. The different methods of injecting will be given in a subsequent work, in this place it will be merely necessary to enumerate some of the objects of the greatest interest that may be selected from the mucous membranes, either injected or not, that may serve as a guide to the understanding of the different elements of which it is composed; these are as follow:—

<i>Epithelium.</i>	<i>Basement Membrane.</i>
Scaly—Skin of Newt,	Tubuli of stomach, Dog,
„ Web of Frog's foot,	————— Porpoise,
„ Mesentery, Rabbit,	Sudoriferous duct, Man,
„ ————— Mouse,	Tubuli of testis, Guinea-pig.
„ Mouth, Human,	
„ Cuticle,	<i>Ciliated Epithelium.</i>
„ Cornea of eye.	Frog's mouth,
Prismatic—Villi of small intestine	Infusoria—Leucophrys,
„ Gall bladder,	Rotifer,
„ Septum nasi.	Polypes,
Spheroidal—Tubuli of Kidney,	Branchiæ—Oyster,
„ ————— Stomach,	„ Mussel,
„ ————— Dog,	Back part of nose,
„ ————— Porpoise,	Bronchial tubes,
„ Liver, Man,	Ventricles of brain,
„ ————— Pig.	Tubuli of kidney.

The following list of specimens of injected mucous membranes has been kindly supplied by Mr. Topping:—

<i>Gall-bladder.</i>	<i>Intestine.</i>	
Bear,	Adder,	Eel,
Cat,	Boa Constrictor,	Fowl (domestic),
Ox,	Cat,	Frog,
Sheep.	Dog,	Goose,
		Guinea-pig,

Hedge-hog,	<i>Lung.</i>	Toad,
Horse,	Adder,	Tortoise,
Human,	Boa Constrictor,	Turtle.
——— <i>foetal</i> ,	Baboon,	<i>Liver.</i>
Mouse,	Bear,	Boa Constrictor,
Pheasant,	Cat,	Eel,
Pig,	Dog,	Frog,
Pigeon,	Dolphin,	Guinea-pig,
Rabbit,	Eel,	Rabbit,
Rat,	Fowl (domestic),	Rat,
Sheep,	Frog,	<i>Oviduct.</i>
Snake,	Golden Eagle,	Fowl (domestic),
Toad,	Guinea-pig,	Pheasant,
Tortoise,	Hedge-hog,	Snake,
Turtle.	Horse,	Tortoise.
<i>Kidney.</i>	Human,	
Bear,	——— <i>foetal</i> ,	<i>Stomach.</i>
Boa Constrictor,	Ichneumon,	Boa Constrictor,
Cat,	Kitten (3 days old),	Cat,
Dog,	Mouse,	Guinea-pig,
Fowl,	Pheasant,	Hedge-hog,
Frog,	Pigeon,	Human,
Hedge-hog,	Puppy (4 days old),	——— <i>foetal</i> ,
Human,	Rabbit,	Snake,
Rabbit,	Salmon,	Tortoise,
Sheep,	Sheep,	

Since the discovery of epithelium upon mucous membranes, the same thing has been found upon serous and synovial membranes, which are supposed now to be only peculiar modifications of the former; the layer is a single one, and is best seen in the mesentery of small animals, and in the synovial fringes of joints. These synovial fringes, when injected, are remarkably beautiful objects; by some persons they have been looked on as small masses of fat, but on microscopic examination, the notion as to their being of a glandular nature, as was described by some of the older anatomists, will be found to be correct. To examine the epithelium from these parts, the mesentery of a small animal, such as a mouse, guinea-pig, or rabbit, should be taken as soon after death as possible; the epithelium may be best seen on the parts that are slightly folded, with a power of two hundred diameters.

Besides the membranes last described, the arrangement of the capillaries in certain of the elementary tissues, though not so numerous a class, yet will form quite as beautiful objects for examination. A list of these, most of which are supplied by Mr. Topping, is here given for the information of those who, though interested in such matters, are, nevertheless, out of the way of procuring them:—

Areolar Tissue, Human,	Adipose Tissue, Cat,
Muscle,	————— Dog,
———— Frog,	————— Human, old,
———— Pig,	Nerve, Human,
———— Human,	———— Pig,
Tendon, Cat,	———— Kitten,
———— Human,	Nervous matter,
Cartilage articular, Human,	———— white, Human,
———— Pig,	———— Kitten,
———— Calf,	———— grey, Human,
Fibro Cartilage,	———— Kitten,
Periosteum, Human,	Eye (Choroid) Cat,
———— Pig,	———— Fowl,
Bone, Calf,	———— Human,
—— Lamb,	—— Postr. Capsule of Lens, Kitten,
—— Sucking-pig,	———— Pig,
Pulp of Tooth, Human,	—— Membrana Pupillaris, Kitten,
———— Kitten,	———— Puppy,
———— Pig,	—— (Cornea),
———— Calf,	———— Cat,
Enamel Membrane, Pig,	———— Dog,
———— Human,	———— Kitten.

Objects for Polarized Light.—The application of the polarizing apparatus to the compound microscope was first made by Henry Fox Talbot, Esq., since which it has been much employed by Sir David Brewster, Sir John Herschell, and other great authorities; and as it now forms so important an instrument for the determination of the slightest differences of density in the most delicate structures, its use to the anatomist and chemist is indispensable; but for those who may only wish to know the kinds of objects that show the richest tints of colour when viewed by polarized light, Mr. Topping has supplied the author with the following list. Many of the

objects contained therein, it will be noticed, have already been given under different heads; but, notwithstanding this, it has been deemed the best plan to repeat them, that they may all be arranged as objects for the polarizing microscope. They are here, however, for the sake of convenience, divided into three classes, viz., the animal, vegetable, and mineral:—

<p style="text-align: center;"><i>Animal.</i></p> <p>Bone of Cuttle-fish, Hoof of Ass, —— Camel, —— Horse, —— Ox, —— Sheep, Horn of African Rhinoceros, —— transverse section, —— vertical section, —— Indian Rhinoceros, —— Antelope, —— Ox, —— Sheep, Quill, Grey human hair, Raw silk, Scale of Eel, —— Sole, Spicules of Gorgonia, Wing cases of Beetles, animal matter of.</p> <p style="text-align: center;"><i>Vegetable,</i></p> <p>Starch, —— Arrow-root, —— Custard-powder, —— Indian-corn, —— Tous les mois, Gun-cotton, Hairs from leaf of Deutzia, —— Elæagnus,</p>	<p>Hairs from leaf of Olive, Raw Cotton, —— Flax.</p> <p style="text-align: center;"><i>Mineral.</i></p> <p>Agate, Brighton Pebble, Crystals of Bichromate of Potash, —— Borax, —— Boracic Acid, —— Borate of Ammonia, —— Borax & Phosphoric Acid, —— Carbonate of Lime, —— Chromate of Potash, —— Cholesterine, —— Citric Acid, —— Epsom Salts, —— Murexide, —— Nitrate of Barytes, —— Lead, —— Satin Spar, —— Sulphate of Cadmium, —— Copper,</p> <p>Granite, Marble, Rhaphides Hyacinth, —— Onion, —— Rhubarb, Sea-sand, Tremolite, Zeolite, Selenite of different thicknesses.</p>
--------------------------------------------------------------------------------------------------------------------------------------------------------------------------------------------------------------------------------------------------------------------------------------------------------------------------------------------------------------------------------------------------------------------------------------------------------------------------------------------------------------------------------------------------------------------------------------------------------------------------------------------------------------------------------------------------	--------------------------------------------------------------------------------------------------------------------------------------------------------------------------------------------------------------------------------------------------------------------------------------------------------------------------------------------------------------------------------------------------------------------------------------------------------------------------------------------------------------------------------------------------------------------------------------------------------------------------------------------------------------------------------------------------------

Selenite.—As before stated at page 219, laminae of this mineral, or of mica, will be required of different thicknesses; these may readily be split off from a large crystal by a pen-

knife or other sharp instrument; for the purpose of being used, the laminae should be placed between two plates of thin glass, either with or without Canada balsam. A piece of plate-glass, three or more inches long, and an inch-and-a-half wide, with a raised edge, and having a thin lamina of selenite cemented upon it, and covered by a piece of thin glass with Canada balsam, is employed by some persons as a selenite stage, and upon this the object that is intended to be examined is placed.

Crystals of Salts.—These may be easily prepared by crystallizing slowly a boiling saturated solution of the salt upon a cold glass slide; the crystallization can be effected very rapidly by warming the under surface of the glass over a lamp. To get the finest crystals, the more slowly the solution is allowed to evaporate the better; the uncrystallizable part, or mother-liquor, as it is termed, should be removed either with blotting-paper or a glass tube. Several specimens of each sort should be crystallized on slides, and those that show best, selected; the others may easily be cleaned off. If any of the specimens are required to be kept, they should be mounted either in the dry way or in Canada balsam; in order to preserve them from being injured by the pressure of the cover, a cell of paper, cardboard, or glass, should be placed round them, and the cover cemented, as before described at page 285. According to Mr. Fox Talbot, a solution of sulphate of copper, to which a small portion of nitric ether has been added, will crystallize in the form of rhomboids; these, when viewed under polarized light, resemble brilliant rubies, emeralds, and other gems; according to the same gentleman, the oxalate of chromium and potash, dissolved in water, and rapidly crystallized, is a splendid object. Sir David Brewster recommends the Faro Apophyllite, when the prisms are complete, as exhibiting most gorgeous colours. If it be wished to examine the crystals of any salts during their formation, the crystallization should be carried on in a glass that is slightly concave; one of the cells represented by figs. 161-2 will be found to answer the purpose, but the best apparatus of all will be the small concave discs of glass about a quarter-of-an-inch in

diameter, three or more of which, set in a frame of metal, were generally supplied with all the old microscopes, and were employed for containing infusoria, as well as for viewing the crystallization of salts. All those crystals that are so thin as not to appear light, or to exhibit colours when the field of view is made dark by the position of the prisms, may have colour given them when placed upon the selenite stage or when a film of the same material is laid under them. Many organic substances also, though they do, to a certain extent, appear luminous upon a dark ground, may be made to exhibit colours when placed over selenite. If colour only be required to be shown by any given object, the method of Mr. King, as described at page 224, will be found the best to be adopted, as then any preparation, whatever its structure, will exhibit the effects of polarized light. The plan of preparing the sections of whalebone, horns, hoofs, hairs, &c., has already been given at page 313; and at page 305, the best method of procuring the siliceous skeletons of grasses; whilst at page 370, the names of the finest specimens to select for the purpose are mentioned. So little being yet known as to what effect is produced by polarized light upon many of the most delicate organic structures, it should be laid down as a rule, that every new variety of tissue be submitted to its action, and doubtless many important results would follow.

Currents in Fluids observed during their evaporation.—Mr. Varley, in the fiftieth volume of the *Transactions of the Society of Arts*, first introduced a series of experiments on this subject to the attention of microscopists. The plan recommended is as follows:—Take an animalcule cage of moderate size, and upon the tablet place a drop of turpentine or spirits of wine, &c., then slide over it the thin glass cover, but do not compress the fluid very much, and the microscope being placed in the vertical position, and provided with a magnifying power from forty to one hundred diameters; the contents of the cage are to be examined in the same way as if animalcules were contained in it; as the evaporation of either of these fluids takes place, numerous currents and vortices will be seen, especially if a small quantity of finely powdered coal be

ground into them; the particles of coal being very light, are held in suspension whilst the evaporation is going on, and, by the currents, are whirled about in different directions. The following fluids Mr. Varley has given as the best for the illustration of the currents:—

“1. A drop of spirit of wine, or of naphtha, exhibits two, three, or four vortices or centres of circulation, according to the size of the drop; and if these vortices are viewed laterally, the lines of particles will be seen forming oblique curves from top to bottom of the drop.

“2. Oil of turpentine shows a rapid circulation in two continuous spirals, one to the right, the other to the left, around the drop. These meet in the opposite diameter, from which the particles are carried slowly across the diameter to the place of starting, and this continues while there is fluid enough to let it be seen.

“3. If, however, the drop does not exceed one-tenth of an inch in diameter, it presents the appearance of particles continually rising up in the middle, and radiating in gentle curves to the circumference.

“4. If the liquid be put into a very small phial, similar motions are perceived, the particles when they have reached the side of the phial, going down to rise up afterwards in the centre or axis.

“5. If a bubble of air be enclosed in the liquid, motions, similar to those described in No. 2, are observed in the part immediately in contact with the bubble.

“6. In a flat drop of new wine laid on the tablet or disc of the aquatic live box, but not compressed by the cover, the motion was a regular uniform circulation, the particles rising from below at one end of the drop, then passing straight across on the surface, and descending at the other end.”

Method of Viewing the Spiral Fibres in the Testa of the Seeds of Salvia, Collomia, &c.—For this purpose a full sized seed of any of the species of the subjoined genera should be taken, and a very thin slice of the outer brown part or *testa* cut off with a sharp knife; place this on a glass slide, or on the tablet of an animalcule cage, and subject it to the micro-

scope, which for the purpose should be provided with a magnifying power of about fifty diameters, bring the object into focus, and then lay over it a cover of thin glass; if now a drop of water be brought near to either of the edges of the cover, it will immediately run underneath it, and spread itself over as much space on the slide as the thin glass occupies; if the testa be now carefully watched, numbers of transparent tubes containing spiral fibres will be found to grow, as it were, from all parts of it; this operation will last for the space of two or three minutes, when it will stop. When the animalcule cage is used, a drop of water may be placed on one part of the tablet, and the portion of testa at some little distance from it; the cover should then be slid on, but not so far down as to reach the water, the testa having been adjusted to the focus, and when all is ready, the cover may be slid so far down as to press the water all over the tablet, and the giving off of the cells will take place as before.

The seeds in which this property resides had been long known to become covered with a white flocculent matter like mould, after having been placed but a very short time in water, and the appearance was generally attributed to the first act of growth of the seed; but the microscope shows that it is due to the elongation of membranous cells, by the uncoiling of an elastic spiral fibre contained within them. The same phenomenon has been observed by Mr. Kippist in the seeds of the *Acanthodium spicatum*, a plant brought from upper Egypt by Mr. Holroyd; also in other plants of the family *Acanthaceæ*, but the presence of spiral cells is not constant throughout the whole family. The entire surface of the seed of the *Acanthodium* is covered with whitish hairs, which are so compressed as to adhere closely to it in the dry state, being apparently glued together at their extremities. On being placed in water, these hairs are set free, and spread out on all sides, they are then seen to be clusters of from five to twenty spiral cells, which adhere firmly together in their lower portions, while their upper parts are free, separating from the cluster at different heights, and expanding in all directions like plumes, forming a very beautiful microscopic

object. The free portions of the cells readily unroll, exhibiting the spire, formed of one, two, or occasionally of three fibres, which may sometimes be seen to branch, and not unfrequently break up into rings. Throughout the whole length of the cell, the coils are nearly contiguous; in the lower part they are united by connecting fibrils, and towards the base of the adherent portion become completely reticulated. The testa is a semi-transparent membrane, formed of nearly regular hexagonal cells, whose centre is occupied by an opaque mass of grumous matter. Those cells which surround the bases of the hairs are considerably elongated, and gradually tapering into transparent tubes, appear to occupy the interior of the spiral clusters.

Two species of *Blepharis* are mentioned as possessing a structure very similar to that of *Acanthodium spicatum*, differing chiefly in the smaller and more uniform diameter of the spiral cells, and in their thicker fibre, which is always single and loosely coiled.

The seed of *Ruellia formosa*, on being placed in water, develops from every part of its surface single, short, thick tapering tubes, within which, in some cases, a spiral fibre is loosely coiled, whilst in others the place of the spiral fibre is supplied by distant rings. The seeds of the following plants should be selected and treated in the manner above described:—

Acanthodium spicatum,	Collomia grandifolia,	Ruellia formosa,
Blepharis, —————	—————linearis,	Salvia pratensis,
Casuarina,	Phayloopsis glutinosa,	Salvia —————

Besides the objects belonging to the animal and vegetable kingdom previously described, there are others which, though mineral in their nature, are nevertheless composed largely of the remains of organized beings; they may be classed, first, into those that are of animal origin, or contain the remains of animated beings; and, secondly, into those that are entirely of a mineral formation; the former require to be viewed either when in a state of minute division, or when cut into very thin slices, whilst the latter may generally be examined

as opaque objects, with a low magnifying power, and without any previous preparation. The sand found largely upon the sea-shore, in some parts of the world, and that met with in the interior of shells and sponges, is exceedingly rich in minute foraminifera, and spicules of gorgonia and sponges; the bins in the shops of merchants who prepare and deal in West Indian and Turkey sponges, will afford a rich harvest to the microscopist. The sand from the *Calcaire grossiere*, of Grignon, near Paris, is exceedingly rich in very beautiful forms; so also is that from the island of Delos. The shells may be picked out from either of these by the employment of a black card, a sharp-pointed sable pencil, and one of the single microscopes represented by figs. 27, 33, and 34; they should be mounted either on black discs or in cells; being of a white colour, they will appear to the best advantage upon a black ground. The following list of names will include some specimens that are remarkable for the abundance and elegance of form of the animal remains found in them, and others strictly mineral, whose gorgeous colours are only rivalled by the brilliant plumage of the humming-bird, or by the splendid hues sometimes displayed by polarized light:—

<i>Sections.</i>	Bismuth,	<i>Oolites.</i>
Granite,	Copper, Pyrites,	Bath,
Limestone,	—— Peacock,	Caen,
—— foliated,	—— native,	Doultling,
—— magnesian,	—— Ruby,	Portland.
Moss Agate.	Iron, Elba,	
	—— Pyrites,	<i>Sand.</i>
<i>Minerals.</i>	Tabasheer,	Grignon,
Antimony Sulphuret,	Tin, crystallized,	Delos,
Avanturine,	Tourmaline,	Java,
—— artificial,	Zinc, crystallized,	Turkey Sponge,
		West Indian Sponge.

Binoxide of Mercury.—A very interesting object for the microscope is the recently sublimed deuto-ioduret, or biniodide of mercury. “This salt, when first sublimed,” says Mr. Varley,* “is of a bright yellow colour, which rapidly

* Vol. XLIX. of *The Transactions of the Society of Arts*, page 194.

changes to red; the manner in which this change takes place being the subject for investigation, and it is well worthy of further attention, as indicating, very probably, the structure of the crystals. To examine them, place a few grains of the deuto-ioduret of mercury in a watch-glass, and invert over it another glass of the same size; apply the heat of a spirit-lamp, and when fumes issue from between the glasses, remove the lamp, and suffer the glasses to cool a little; on removing the upper glass, it will be found lined with yellow crystals, one of which should be rapidly transferred to the stage of the microscope for examination as a transparent object; lines of a beautiful red will be seen shooting through the crystal, until it has entirely changed colour: during the time it is changing colour, it will also be seen to change its form. If it be placed on the stage of the microscope very carefully and gently, the crystal will sometimes remain a considerable time before it begins to change colour; in that case, if it be touched with the point of a pin, the red lines will be seen shooting very beautifully from the point of contact. For a knowledge of this beautiful microscopic object, Mr. Varley states that he was indebted to Mr. Morson."

More recently the changes of colour in the biniodide have been investigated with great care by Mr. Warington, and an account of his experiments published in the first volume of *The Memoirs of the Chemical Society*, to which the author would beg to refer the reader, as the method of viewing the crystals, both by ordinary and polarized light, is rather different from that described by Mr. Varley. The paper is also furnished with illustrative diagrams, and with an account of the apparatus employed for the due display of the crystals.

Tongue of the Whelk and Limpet.—In the several lists of animal structures before described, the tongue of the Buccinum or Whelk, and that of the Patella or Limpet, were accidentally omitted; and as this organ in these Gasteropods is of great interest to the microscopist, a few hints on the dissecting and mounting of the same may not be out of place here. The tongue of the Whelk is contained within a proboscis of large size, which is capable of being protruded, and of

being again quickly retracted within itself, in the same manner as the finger of a glove; the tongue is of a horny structure, covered with spines and hooks of silica, which are arranged in parallel rows; it is sustained by two long cartilages, whose extremities form two lips that can be separated or approximated; or the cartilages can be made to move upon each other by the mass of muscles in which they are imbedded. When the cartilages move, the spines are elevated and depressed alternately; and by a repetition of similar movements, the hardest shells are speedily perforated.* The proboscis is easily found when the animal is taken out of the shell; it should be slit up with a pair of scissors or a scalpel, and as soon as the tongue is reached, it may be easily separated from the cartilage to which it is attached; after a slight washing, or even maceration in water, it should be laid on a slide, with its spiny side uppermost, and pressed quite flat, so that in drying it may adhere to the glass; it should then be surrounded with a cell of paper or card-board, and the cover cemented down either with sealing-wax or the electrical cement; if required for polarized light, a specimen mounted in balsam will answer. A power of forty diameters is sufficient for examining this remarkable organ, which can be viewed either as a transparent or as an opaque object.

The tongue of the Patella, or Limpet, though not so beautiful a structure as that of the Whelk, is, nevertheless, a very interesting object; it is remarkable, also, for its length, being often three times that of the body; it is supported on two cartilaginous pieces, placed on each side of its root; from these arise strong and short muscular bands, which move the organ. The surface, like that of the Whelk, is covered with spines, or teeth, placed in transverse rows, and arranged in three series; each central group has three or four spines, but those on the sides contain only two; the anterior part should be selected for examination, as there the teeth are the firmest. On opening the body of the animal, the tongue is seen doubled up upon itself, and folded in a spiral manner,

* *General Outline of the Animal Kingdom.* By T. Rymer Jones, F.Z.S. London, 1841.

from which situation it can readily be detached.* In consequence of its length, this tongue cannot be mounted in the same manner as that of the Whelk; the best plan to adopt is to coil it up in a tubular cell, and mount it in fluid; short lengths may be dried, in order to display the structure of the teeth.

Some of the Gasteropods are provided with a muscular gizzard, armed with gastric teeth of stony hardness; these are also interesting subjects for examination, the larger kinds may be ground down thin, and viewed as transparent objects, whilst the smaller can be mounted as opaque objects, and examined in situ. The principal genera in which the gastric teeth may be seen, are *Bulla*, *Scyllæa* and *Aplysia*; but the most remarkable forms occur in the last mentioned genus.

CHAPTER XIX.

METHODS OF EXAMINING MORBID STRUCTURES, ETC.

Methods of Examining Specimens of Morbid and other Structures.—Those who devote their attention to the examination of morbid structures, viz., members of the medical profession, are, perhaps, by far the most numerous class of microscopic observers, and certainly the advancement of the healing art is the noblest of all uses to which so powerful an auxiliary as the microscope can ever be applied. It has, therefore, been thought advisable to give a few practical hints on the best methods that are now usually adopted of examining any fluids or solids, whether morbid or otherwise. For the purpose of making a correct microscopic analysis of many fluids, certain chemicals will be required; these should consist of liq. potassæ, ammonia, æther, and alcohol, acetic, nitric, hydrochloric, and

* *Cyclopædia of Anatomy and Physiology*, Vol. II., article "Gasteropoda."

sulphuric acids, both in the concentrated form and diluted, together with a few test tubes and watch glasses, and other equally simple apparatus, in addition to the curved and straight tubes represented by fig. 75. In the case of solids, the various kinds of scalpels, dissecting needles, and the Valentin's knife, will all be required.

If the subject for examination be of a fluid nature, such as blood, pus, mucus, &c., the plan generally adopted is to take out of the containing vessel a very small quantity of the fluid by means of one of the tubes shown at fig. 75, or any other convenient instrument, and to lay the same upon a slide wiped perfectly clean, and to cover it with a piece of thin glass; if there be any sediment in the fluid, it should be allowed to subside before the examination takes place, and the tube should then be carried to the bottom of the vessel before the finger, as shown in fig. 75, is taken off the end; the sediment can then be transferred to the slide. If it should be necessary to apply any re-agent to the fluid or solid under examination, a small quantity may be brought in contact with one of the sides of the cover, when it will gradually insinuate itself between the glasses, and act slowly on what is contained there; in other cases, the cover may be lifted up, and a small quantity of the re-agent added, and the cover quickly replaced, care being always taken that no foreign matters gain entrance into the fluid from without. In the case of blood, the fluids that require to be added are generally ordinary water, serum, and sugar or salt, dissolved in water; but in the case of pus and mucus, which approach each other so closely in many of their characters, it becomes of great importance to have some test whereby they may be distinguished one from the other; the fluid employed for this purpose is acetic acid; when this is added to a fluid where pus is present, the globules swell up, and several large transparent nuclei make their appearance; but when the same acid is added to a fluid where mucus is present, the globules enlarge and show their nuclei, but not so plainly as the pus; and the liquid termed liquor mucii, in which the globules float, is instantly coagulated into a semi-opaque corrugated membrane. The

presence of fatty matter is ascertained by sulphuric ether, which readily dissolves the oily part, and leaves the membranous cell walls untouched. Earthy matters require the aid of the acids for their solution; these should not be added in too concentrated a form, in order that their solvent action may be the more easily witnessed. Solid parts, such as tumours, that are to be examined as transparent objects, with high powers, require for the purpose to be cut into exceedingly thin slices, and separated, if necessary, by the needle-points; the sections are to be placed upon a glass slide, and a little serum, or, in the absence of it, white of egg, in water, should be added, in order to float out certain of the parts, and to lessen the refraction of the light at the edges of the object; water will answer the purpose for some of the hard tissues, but where nucleated, or other cells and nervous matter are present, its use is inadmissible, as it is so liable to alter the true appearance of these structures. The sections may be made with a razor or scalpel; for solid organs, such as the liver and kidney, Valentin's knife, described and figured at page 318, will be found exceedingly useful. It is, perhaps, as well here to state, that the examination of all morbid structures should be made as soon as convenient after their removal from the body, as changes of form in the softer substances speedily take place; but if some time has elapsed, the part from which the sections are taken should be at some little distance from the surface, in order that they may be as little altered as possible by the action of the air.

CHAPTER XX.

TEST OBJECTS.

FOR this important class of objects, to which, in a great measure, must be ascribed the rapid advancement towards perfection of the achromatic compound microscope, we are

indebted to the late Dr. Goring, who, it is said,* was led to adopt them by reading a passage in the works of Leeuwenhoek, relating to the examination of the scales from the wing of the silk-worm moth, the lines on which could not be seen by the draftsman with so low a power as that used by the great microscopist himself. At the time of Dr. Goring's first employment of these objects, he ascertained that the structure of certain of them could be readily made out by some microscopes, and not by others; and, inferring that there were some peculiar properties in the lines on the feathers and scales of certain insects, which rendered them more difficult of definition than others, he was induced to view them through an achromatic microscope, and was led to the discovery that in it there were two distinct powers, viz., defining and penetrating, and that an object-glass might possess the one almost to perfection, and yet be totally devoid of the other, or might be perfect in both. He subsequently made the important discovery, that the penetrating power depended on the angle of aperture of the object-glass; Dr. Goring communicated the result of his labours to the scientific public in the journal of the Royal Institution, and, in 1829, gave a more practical account of the same in the *Microscopic Illustrations* of Mr. Andrew Pritchard, to which the reader is referred. Dr. Goring divided test objects into two classes. In the first he placed those which it was necessary to examine out of focus, such as minute globules of mercury, called "artificial stars," by these the aberrations, achromatism, centering, &c., were ascertained; and in the second the lined, or other objects, which, according as they were well or ill defined, afforded sufficient evidence of the merits of the instrument.

Mr. Pritchard, following Dr. Goring, divides test objects into two classes, viz., into those that are tests of the penetrating, and those of the defining power of the instrument; the word defining power, according to Dr. Goring, meaning nothing more than a destitution of both kinds of aberration, considered independently of the aperture of the microscope, and that of penetrating power merely a large angle of aper-

* *Microscopic Cabinet*, by Andrew Pritchard. London, 1832, p. 137.

ture.* Although this distinction of tests was necessary at the time when Dr. Goring wrote, such is not the case now; the wonderful improvements that have taken place in the construction of achromatic object-glasses within the last fifteen years, whereby all the errors of aberration, centering, and achromatism have been so correctly balanced, have rendered the microscope the most perfect and efficient instrument "ever yet bestowed by art upon the investigator of nature." The division of tests, therefore, into those of penetration and definition is no longer needed, and the words defining power and definition will be the only expressions employed to denote the good or bad qualities of any microscope, for in order that an object-glass may show the tests enumerated by Mr. Pritchard, under the head of "Penetration," in a perfect manner, its definition or defining power must be of the first order, and these terms are, therefore, sufficiently explanatory of the principal point to be attended to in testing two or more glasses. The objects which have been chosen by the author, as illustrations of the definition of microscopes as now constructed, are, with few additions, of the same nature as those employed by Mr. Pritchard, in 1832, and published by him in the *Microscopic Cabinet*. Plate XII. of that work, although at the date of its publication one of the finest specimens of the kind that had ever been executed, when contrasted with Plates V., VI., VII., of the present work, will show, better than words can express, the rapid improvements that have been made in the construction of the object-glass; it will, however, be readily seen that the magnifying powers employed in the latter instance were much greater than those used by Mr. Pritchard, consequently a greater amount of the detail ought to be shown by the one than by the other; this remark would more especially relate to fig. 4 A in Plate VI., and figs. 5, 6, 7, in Plate VII., where, the linear magnifying power used was 1,200. Before enumerating the test-objects, of which a full explanation will be presently given, it will be as well, in this place, to allude to the means employed to ascertain the defects that may be

* *Microscopic Cabinet*, p. 173.

present in any achromatic object-glass; these defects, as before stated, are chiefly spherical and chromatic aberration, centering, adjustment, achromatism, and want of angular aperture. All these, with the exception of the last, are so difficult of detection, that very few persons, except those constantly engaged in the manufacture and testing of object-glasses, can be said to be capable of discovering them. The method usually adopted to ascertain the presence of these defects, is a minute globule of mercury, spread upon a black ground; this is known by the name of "artificial star," and presents a minute point of light. Dr. Goring alludes to the employment of an enamel dial-plate and wire gauze for the same purpose, but only the mercury is now used. Very minute globules of this metal, spread upon a blackened surface, are viewed as opaque objects, being illuminated by ordinary day-light from a window, or by the light of an argand lamp, thrown on them by a condensing lens; when one of the globules is in focus of a single lens object-glass, a strong coma surrounds the miniature image of the window seen in the globule; when the globule is within the focus of the object-glass, the light of the window will be seen to swell out into a circular disc; these appearances are more or less accompanied by prismatic colours. It would be in vain to attempt a description of all the changes that take place, as the globule is brought either within or without the focus; these have, in some measure, been illustrated in one of Dr. Goring's papers, published in the *Microscopic Illustrations* of Mr. Pritchard, to which the author would beg to refer his readers; suffice it here to say, that when an achromatic combination, that is perfectly corrected for spherical and chromatic aberrations, is employed, the globule should exhibit similar appearances, both within and without the best focus; and that when at the best focus the point of light should be seen as a minute disc, free from irradiations and colour, except a general blueness, which results from the irrationality of the spectra of the different glasses of which the object-glass is composed.

It would be needless to enter farther into this complicated subject, as rarely, if ever, will the microscopist find it

necessary to have recourse to such delicate manipulation to try the quality of his magnifying powers, more especially as the subjects now employed as tests of their definition are of such value and so manageable, that, in some cases, a simple inspection, by a practised eye, will at once determine the respective merits of any achromatic combinations, as well as the amount of skill and care displayed in their construction.

Power of definition depends, in a great measure, upon the *angle of aperture* of the object-glass, and correctness of definition upon the balance of the aberrations, and the perfection of the workmanship. As it is of the greatest importance that the meaning of the term angular aperture should be well understood, it has been deemed right in this place to enter into an explanation of the same, as many persons unacquainted with the subject are at a loss to conceive how more light can pass through a combination of three pairs of lenses, than through a single lens of equal magnifying power.

Angle of Aperture.—The following description of this subject, copied from the *Microscopic Illustrations* of Mr. Pritchard, will be found to convey an excellent idea of its nature and value. “Let me premise,” says he, “that in order to render any object visible, it is necessary that rays of light should proceed from it, either by reflection from its surface, or by transmission through it, to the eye. Again, if the number of rays be insufficient, the object cannot be seen, notwithstanding we employ a microscope for the purpose. Bearing this in mind, I will endeavour to explain how an increase in angular aperture in an object-glass, independent of any increase of its magnifying power, will admit a greater quantity of light from any given point on the surface of an object to pass through the lens, so as to render the structure of the object visible.

“Let A and a represent two objects, in all respects alike, and let us employ two microscopes, of equal magnifying powers, for the purpose of viewing them. Suppose that we are going to look at some spot on the surface of A or a , which we will imagine to be a delicate tissue. By a well known law of light, the rays proceed in right lines, in all directions from this spot, in the manner shown by the lines in

figs. 233-4. Suppose BB and bb to be two object-glasses, of equal focal lengths; the former a single lens, of the best

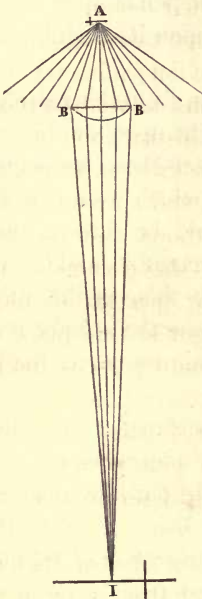

Fig. 233.

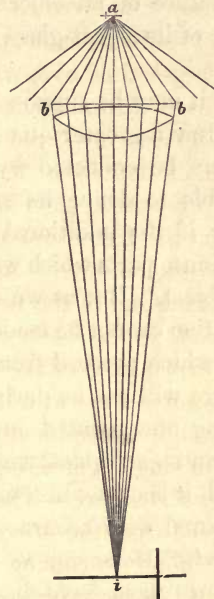

Fig. 234.

construction, such as was used in the old compound microscope, and the latter a lens of the newest form, termed an achromatic. Now, these object-glasses will form their respective images at I and i , and they will be of equal dimensions. But if the number of rays proceeding from A , and falling upon the single lens BB , is not enough, when collected at I , sufficiently to stimulate the eye, any minute pore, stria, or other marking at A , will not be rendered visible; whilst, from the increase of aperture in the achromatic lens bb allowing much more light from a to fall upon it, and to be transmitted through it and collected at i , every marking, &c., at a will be clearly represented at i , and the eye, being powerfully acted upon by this increase of light, will become highly sensible of it.

“The angles BAB and bab are the angles of aperture of the respective object-glasses; and the quantity of light collected and transmitted by each will be as the squares of BB

and bb , the focal lengths being equal. Hence it is that the power of a microscope, or that faculty it possesses to render the structure of an object visible, depends upon the angle of aperture of its object-glass, and not upon its magnifying power alone.

“But it may be supposed, perhaps, from this reasoning, that if we throw a greater quantity of light upon an object, so that more may be collected by the object-glass, we shall be the better able to define its structure, which would probably be the case if the additional light could be thrown only upon those minute parts which we wish to examine, and not upon the whole object. But as we cannot do this, as the increase of illumination cannot be made to increase the *relative proportions* of light which proceed from these minute parts, the intended advantage will not be derived.”

Having now pointed out the importance of angular aperture to an object-glass, when all its aberrations are correctly balanced, it becomes necessary to point out how this angle may be measured with accuracy.

Method of Measuring the Angle of Aperture of Object-glasses.

—Various plans have been adopted from time to time to ascertain this important point; but by far the best of all is that proposed by Mr. Lister, in his paper in the 121st volume of the *Philosophical Transactions*, p. 191, which is as follows:—“Fix a piece of paper on a table, and on it place the microscope, with its body horizontal, and one of the eye-pieces on; set a candle on a level with it, a few yards distant; then having directed the body of the instrument so far on one side of the candle as that the light from it shall bisect the field vertically, leaving half of it dark, trace on the paper a line corresponding to the side of one of the legs; now, taking the focus of the object-glass as a pivot, turn the microscope horizontally to the other side of the candle till the opposite half of the field only is illuminated, and mark again on the paper the position of the side of the leg. The measure of the angle traversed, shown by the two lines, is that of the pencil of light.” The makers of the object-glasses do not usually employ a microscope for the purpose of measuring the angles, but an

instrument of the form represented by fig. 235, for the copy of which the author is indebted to Mr. Ross; it consists of a

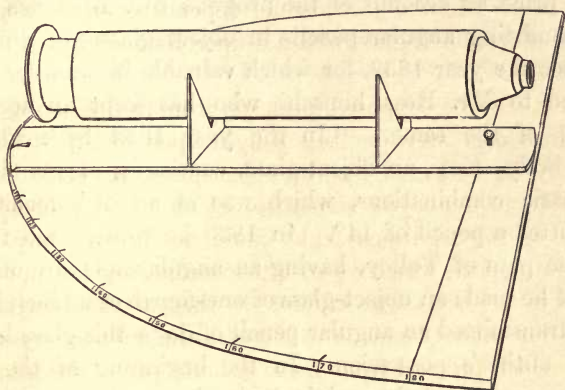

Fig. 235.

piece of mahogany, or other hard wood, of a semicircular figure, about half-an-inch thick, and of sufficient radius to suit the length of an ordinary compound body, the curved edge is graduated into 180° ; upon the flat surface of the semicircle, a strip of wood or index, an inch or more in breadth, is made to turn upon a pin, as seen in the figure; on the upper surface of this index two crutches are fastened to receive a compound body, provided with an eye-piece of the usual Huyghenian construction; the object-glass, whose angle of aperture is about to be measured, is screwed to the opposite end of the body to that of the eye-piece, as in the ordinary compound microscopes. The method of using this instrument is the same as that of the microscope described by Mr. Lister; a candle is placed a few yards off, and the instrument is so arranged, that when the index points to zero, the field of view should be vertically bisected; if now the index be turned so far that the opposite half of the field is illuminated, the number of degrees passed over will give the measurement of the angle of aperture of the object-glass required.

In the early days of achromatic combinations, the angle of aperture was small, and it is very interesting to observe how steadily our first-rate opticians have been progressing towards

the utmost limit of conceivable perfection. As the subject is so important, the author has thought proper to introduce in this place an account of the progress Mr. Ross has made in transmitting angular pencils in object glasses of different foci since the year 1832, for which valuable information he is indebted to Mr. Ross himself, who has kept an accurate account of the same. "In the year 1832 he made for R. H. Solly, Esq., an object-glass, consisting of two double achromatic combinations, which was of an inch focus, and transmitted a pencil of 14° . In 1833 he constructed triples after the plan of Tulley, having an angular aperture of 18° . In 1834 he made an object-glass of one-fourth of an inch focus, which transmitted an angular pencil of 55° ; this glass is now in the author's possession. In the beginning of the year 1836 he constructed a triple inch glass, with an angular aperture of 15° , with cemented surfaces; and towards the end of the same year he made glasses of one-eighth and one-tenth of an inch focal length, which transmitted angular pencils of 60° and 72° . About this time, in conjunction with Mr. Lister, he constructed an inch object-glass of two combinations, the form of the front lens being suggested by Mr. Lister himself; this glass was capable of transmitting an angular pencil of 22° . At this time he also constructed one-eighths, the front glasses of which were also of the form suggested by Mr. Lister; these had an aperture of 63° and 64° ; he continued making these last until the year 1842, when he increased the angle of aperture of the half-inch to 44° , of the quarter to 63° , and the one-eighth to 74° . In the year 1844 Professor Amici visited this country, and brought with him an object-glass of one-seventh of an inch focal length, with an aperture of 112° ; this combination was in part composed of Dr. Faraday's dense glass. Mr. Ross copied Amici's construction; but found the dense glass so exceedingly soft and fragile, as to render it unfit to receive the high polish, so essential to the correct performance of any object-glass: he also noticed that Amici's glasses were much tarnished; he then devised a new construction, whereby, with the ordinary dense glass, he obtained an aperture for

pencils in the one-eighth of 85° , and in one-twelfth as high as 135° , the largest angular pencil that can be passed through a microscopic object-glass." As now constructed, the angular apertures, with the greatest separating magnifying power of object-glasses of different focal lengths, are represented in the following table:—

Focal length.	Greatest separating mag. power.	Angular aperture.	Extreme space separated.
2 inches,	40 diameters,	$12\frac{1}{2}$ dgs.	$\frac{1}{20,000}$
1 "	100 "	22 "	$\frac{1}{35,000}$
$\frac{1}{2}$ "	300 "	43 "	$\frac{1}{65,000}$
$\frac{1}{4}$ "	500 "	63 "	$\frac{1}{100,000}$
$\frac{1}{8}$ "	650 "	80 "	$\frac{1}{120,000}$
$\frac{1}{12}$ "	720 "	120 "	$\frac{1}{155,000}$

The test objects now generally employed for ascertaining the merits of any achromatic combination may be divided into three kinds; viz., hairs of animals, scales from the wings and bodies of insects, and the siliceous coatings of recent and fossil infusoria, those of the latter kind being the most difficult of all to define. The following list contains all those that Mr. Topping is in the habit of furnishing to his customers as test objects, they being covered with the thinnest glass, in order that object glasses of the highest power may be employed upon them:—

Hairs.

Bat,
Larva of Dermestes,
Mole,
Mouse,
Rabbit,
Squirrel.

Tinea vestianella,
Lepisma saccharina,
Podura plumbea,
—— aquatica,
Hipparchia janira,
Plumed Gnat.

Scales.

Azure blue, P. argiolus,
—— P. argus,
Pontia brassica,
Vanessa Io,
Morpho Menelaus,
Alucita pentadactyla,
Catocala nupta,

Infusoria.

Navicula hippocampus,
—— Spenceri,
—— angulata (Humber),
—— (America),
Tripoli from Kritchelberg,
——
Muscular fibre.

From this list the author has selected a certain number of each class, and highly magnified representations of them are given in Plates V., VI., VII., and VIII., which may be looked upon as the finest engraved specimens of these minute structures that have yet been executed, and reflect the greatest credit both on the artist and the engraver, the original drawings having been accurately traced with Mr. Leonard's well-known skill, by means of the Camera Lucida applied to the microscope, the power employed with some of them being as high as 2,000 diameters.

Bat's Hair.—This beautiful structure, represented by A, figs. 1, 2, and 3, Plate V., is obtained from a species of bat, inhabiting some parts of India; it is remarkable as presenting a series of scale-like projections, arranged in the form of a whorl around the central part or shaft; these are least numerous at the base of the hair, as shown at fig. 2, but gradually increase in number and size towards the apex, as seen in fig. 1, near which they are very abundant, but do not project so far beyond the shaft; this may readily be seen by contrasting fig. 3 with fig. 1. In some hairs the succession of whorls resembles very much a series of conical bags placed one within the other; the principal parts of the hair that form a test of the defining power of a half-inch object-glass, are the delicate points that surround the upper edge of each whorl; these, with a well-constructed combination, should be shown exceedingly sharp, and the whorls themselves made to stand boldly out from the shaft; in some of the small species of English bats, the whorls are arranged in a spiral form; but in this specimen there is plainly no such disposition.

Mouse Hair.—The hair of this common little animal differs materially both in structure and in size from that of the bat above noticed; at B, in Plate V., are shown four parts of a large dark hair, whilst at D, in the same plate, corresponding portions have been selected from a small flat hair. At B 1 is shown the base of one of the large hairs, on which are certain markings, whilst in 2 and 3 the internal structure is seen to be cellular, there being three or more cells in each row, the colour of the hair depending upon the greater or less

amount of the black pigment contained in the cells. When viewed with a power of 100 or 200 diameters, all the light parts should be shown distinctly from the dark, and the line of separation of the two correctly defined. The apex of the large hair is seen at 4; it is of very small size as compared with the central portion, and exhibits no trace of cell in its interior.

At D are shown four parts of one of the small flat hairs from the same animal; the structure of the base and apex, as seen at 1 and 4, is similar to that of the larger hair; but the internal character of the intermediate portions, as exhibited at 2 and 3, is very different; in 3, the dark cells extend entirely across the hair, and are arranged at equal distances, whilst at 2 a rudimentary form of cell, containing a small quantity of pigment, is seen to occupy the central portion of the shaft. The figures represented by B and D were drawn by a magnifying power of 500 diameters; but as a test of the defining power of a half-inch object-glass they should be chiefly employed. When viewed as an opaque object, this hair is very beautiful, the dark parts will then appear very much more light than those that are transparent, and the structure will be imagined to be quite the opposite of that seen by transmitted light.

Hair of the Dermestes.—This very remarkable hair is obtained from the larva of a small beetle, commonly met with in bacon and hams and other dried animal substances; it is covered over with brownish hairs, the longest specimens of which should be selected. When one of these is viewed with a magnifying power of 200 diameters, the upper part presents the appearance shown at C 1, and may be said to consist of a shaft and expanded extremity or head; the shaft, like that of the hairs of some other larvæ, is covered with whorls of large close-set spines, four or five in number in each whorl; these are closely arranged one above the other, as seen at 2; the upper part of the shaft, near the head, is provided with several larger and more obtuse spines, forming a knob; above this, as seen in 1 and 3 the shaft is naked for a very short distance; it then becomes invested with six or seven large filaments or spines, which are pointed at their distal extremities, and pro-

vided with a small protuberance at their proximal ends, where, by slight pressure, they may be separated one from the other, as seen at 3, or they may sometimes be detached at the apex, as seen at 1. In the early days of testing microscopes, these hairs were found rather difficult of definition, and no one would imagine that fig. 20, in Mr. Pritchard's twelfth plate, before quoted, was of the same nature as C 1, 2, 3, in Plate V. of the present work. This very beautiful hair now forms a good test of the defining power of a half-inch object-glass.

We now come to a class of objects much more difficult to exhibit than any of the preceding, these will form excellent tests of the good qualities of the quarter and one-eighth of an inch object-glasses, and consist of scales removed either from the wings or the body of insects.

Hipparchia Janira. (Common meadow brown butterfly).—This test was first shown in this country by Amici, in 1844, by his object-glass of large angular aperture, before described at page 39. Fig. 1, Plate VI., exhibits one of these scales magnified 500 diameters; on it may be seen longitudinal striæ, with a number of brown spots of irregular shape; when the magnifying power is increased to 1,200 diameters, the brown cells are made more evident, but the striæ are, in a great measure, obscured by them, as shown in Plate VII., fig. 7.

Pontia Brassica (Common cabbage butterfly).—This scale, like that of the *H. janira* above noticed, is provided at its free extremity with a brush-like appendage; when magnified 500 diameters, it presents the appearance shown by Plate VI., fig. 2; the striæ seen on it are longitudinal, which, with this power, appear to be composed of rows of little squares or beads; when a power of 1,200 is employed upon them, the striæ have between them elongated dots or cells, probably of pigment. Fig. 5, Plate VII., represents a portion of fig. 2 magnified 1,200 diameters; and fig. 6, in Plate VII., a portion of one of the coarse scales from the same insect viewed under similar circumstances.

Polyommatus Argiolus (Azure blue).—One of the delicate scales from this beautiful insect is shown at fig. 3, Plate VI., magnified 500 diameters; it exhibits under this power both

longitudinal and transverse striae, the latter being much more delicate and difficult to detect than the former. This scale forms a very good test of the defining power of a quarter-of-an-inch object-glass.

Scales of Podura (common springtail).—The body and legs of these tiny creatures are covered with scales of great delicacy; according to Mr. Pritchard,* their value as test-objects, for the high powers of the microscope, was discovered by the late Mr. Thomas Carpenter, of Tottenham, whilst making some experiments with a plano-convex jewel lens, adapted as an object-glass to a microscope, provided with a Huyghenian eye-piece; since his time they have been employed, even up to the present period, as tests for the higher powers; but many persons now use specimens of infusoria of the genus *Navicula* for the same purpose. Two of the scales from the body are represented by figs. 4 and 5, as seen under a magnifying power of 500 diameters; that shown at fig. 4 is one of the largest that could be procured; whilst that at fig. 5 is very small, and its markings exceedingly delicate. The surface of each appears covered with immense numbers of delicate wedge-shaped dots or scales, arranged so as to form both longitudinal and transverse wavy markings; but when a portion of fig. 4 is magnified 1,250 diameters, it presents the appearance shown at fig. 4a; the scales may then be seen to stand out boldly from the surface; at the upper part of the scale they also project beyond the edge. It would appear from Mr. Pritchard's figure, that at the time of the publication of the work above quoted, nothing but longitudinal and oblique lines could be made out, the powers then employed not being able to separate the longitudinal ones into a number of very minute elongated dots or scales, and the transverse ones into rows of the same, arranged somewhat in a wavy manner. The smaller scale, fig. 5, is very much more difficult to exhibit than the larger one, and forms a good test of the defining power of a one-twelfth or one-sixteenth; the markings are of precisely the same nature as those of the larger scale, but are much more difficult to bring out.

* *Microscopic Cabinet*, p. 150.

These insects abound in damp cellars, where they may be seen running or skipping upon the damp walls. Mr. Pritchard recommends the following method of collecting them, viz.:—“To sprinkle a little oatmeal or flour on a piece of black paper, and lay it near their haunts; after a short time the paper may be removed and carefully placed in a glazed bason, so that when they leap from the paper, on being brought into the light, they may fall into the bason, and thus separate themselves from the bait. They should be cautiously handled, and placed either in little tubes or boxes, with camphor to preserve them from the ravages of other insects.*

Scales of Lepisma Saccharina.—These are so easily made out by the lowest powers, that they can hardly be called by the name of tests. Figs. 8 and 9, in Plate VIII., represent two of the scales magnified 500 diameters; the longitudinal striæ appear to stand out in bold relief, like the ribs on a shell; they are smallest at the lower part of the scale, and increase in breadth, and become more prominent as they proceed towards the outer margin; a good glass should define well the contrast between the striæ and the interspaces.

Scales from the Gnat's Wing.—Two of these are represented by figs. 1 and 2, in Plate VII.; when magnified 500 diameters, they exhibit very bold longitudinal bands or striæ, which project beyond the end in the form of spines; in the membrane, between the longitudinal striæ, there is sometimes an appearance like the watering of a silk. If one of these scales be viewed with a twelfth of 90° aperture, numerous striæ will be seen; but if, on the same scale, one of 130° be employed, half of the lines will disappear, which proves that the first effect was due to interference.

Battledoor Scale of Polyommatus Argiolus (azure blue).—One of these elegant scales is represented at fig. 3, Plate

* It is said that the French opticians employ as a test the scales of a species of Podura, named *Petrobius maritimus*, which is very abundant on the sea coast; the markings on these scales are very strong and easily made out by second-rate instruments, hence some caution is necessary that proper scales be selected for examination, the best of all being those of the kind shown by fig. 5.

VII., as seen under a magnifying power of 500 diameters; when badly defined, its surface appears covered with coarse longitudinal striæ; but under a good object-glass the striæ are interrupted by small rings, having a hair-like projection from the centre of each; the rings are at some little distance apart, and are joined together by minute longitudinal striæ; in the lower part of the scale there is a curved band with its convexity towards the point of attachment of the scale, which consists entirely of minute black dots of pigment; the striæ between this band, and what may be termed the quill of the feather, are not interrupted by rings, but consist of continuous lines, having black dots upon them. A good defining power should show the dots and the rings with the connecting striæ between each very distinctly.

Scale of Morpho Menelaus.—A scale of this splendid butterfly is shown at fig. 4, Plate VII., magnified 500 diameters; it exhibits strongly marked longitudinal and very delicate transverse striæ, the former frequently bifurcating. In former times it required a good quarter to exhibit the transverse striæ; but the half-inch, as now constructed, will show them readily. In taking the scales from the upper surface of the wing of this beautiful insect, the pale blue specimens should be selected; many of these have a thick coating of colouring matter, and in examining a series of them, it will often happen that scales will be seen having certain spaces or parts of their surfaces more transparent than the rest, and without any trace of striæ; this is due to the removal of the pigment, and with it the striated layer. This object forms a good test for the half-inch object-glass, which should show clearly the transverse striæ; and if the scale be perfectly flat, the striæ should be seen over the whole of its surface; but it generally happens that they are only well defined in certain situations. The pigment, under very high powers, exhibits a dotted appearance between the striæ.*

For many years, several species of siliceous infusoria of the genus *Navicula* have been employed as tests; but with im-

* The structure of certain scales is now being investigated by Mr. De La Rue, Mr. Topping having directed his attention to some peculiar markings on their surfaces.

proved object-glasses the lines or dots on their surfaces can be so easily made out, that they are no longer employed; but in more modern times, several new species have been discovered, which even now require the aid of the highest powers and most careful manipulation to show their true characters; the first of these, and the one most easily exhibited, is the *Navicula Hippocampus*. This beautiful species was first brought under the notice of the microscopists in this metropolis, by Mr. Robert Harrison, of Hull, in June 1841, the longitudinal striæ, on the surface of which, he was the first to discover. After a careful examination of the same infusoria at a subsequent period, Mr. Harrison also detected transverse striæ as well; but these he found more difficult to exhibit than the longitudinal series. A representation of this animalcule is given in Plate VIII., fig. 1, as seen under a magnifying power of 500 diameters, and at fig. 2 under one of 1,200.

It will be noticed that the so called longitudinal and transverse striæ are resolved into dots, which are so arranged as to present under object-glasses of low power the appearance of longitudinal and transverse lines. When viewed by a power of 500 diameters, it is readily seen that its surface is convex, and that the dots are projections from the surface; a curved structureless line runs down the middle of the shell in the centre, and at each end the line is expanded into an oval spot; on the edges, near the central spot, the dots are elongated transversely, and appear as so many short bands. This species of navicula is an excellent test for a quarter-of-an-inch object-glass, which should show distinctly both sets of lines or dots by oblique illumination.

Navicula angulata.—This exceedingly beautiful species was first found upon conferva in the Humber at Hull, and three sets of lines discovered on it by some microscopists residing there; since then, its structure has been carefully worked out by Mr. Gillett, by an improved method of illumination and of mounting between thin glass; these supposed lines have been resolved by him into minute dots or elevations from the surface, which are so arranged as to present both longitudinal, transverse, and oblique markings, under certain conditions of illumination. Fig. 4, Plate VIII., is an entire specimen seen under a

magnifying power of 500 diameters; and fig. 5 a portion of the same magnified 1,200 diameters, whilst at fig. 6 is represented a still more highly magnified view of a portion of another specimen, for which the author is indebted to Mr. Gillett, from whose microscope it was sketched by Mr. Leonard; the angle of inclination of the dots to the sides of the shell was found on measurement to be 51° in some specimens, and nearly 60° in others. Whenever these infusoria are viewed by means of very oblique light, the appearances presented are those shown in figs. 4, 5, 6; but under the most favourable illumination, either from a white cloud, or a lamp with direct light, and a magnifying power of at least 1,200 diameters, the lines are all shown to be dots or elevations from the surface, as exhibited as they occur on a small portion of the scale by fig. 7. Figs. 1, 2, 4, 5, 6, are all exceedingly useful in their way, to show how by very oblique pencils of light, with glasses of small aperture, dots closely approximated may be converted into lines.

Another very good test of the defining power of a microscope is the ultimate structure of voluntary muscular fibre, about which many differences of opinion have been raised. The most excellent specimens of this beautiful structure that have yet been shown, are those prepared by Mr. Lealand, from one of which, with his kind assistance, figs. 10, 11, 12, have been drawn by Mr. Leonard. Fig. 10 represents a portion of a muscular fibre or fasciculus of a pig magnified 600 diameters, which has been so far separated, as to exhibit the structure of the ultimate fibres or fibrillæ. Fig. 11 is a specimen taken from another part of the same preparation, but magnified 1,200 diameters; in this it will be seen that each fibril is composed of alternate bands or stripes of two distinct structures; but, on more careful examination, a transverse line will be found between each dark band, which gives to the fibril an appearance of being composed of a linear series of more or less oblong or square cells, with a dark substance in the centre of each, as shown in fig. 12. In some cases, as in fig. 11, the transparent cell wall cannot be easily seen, the dark substance extending as far as the sides of the cell.

Navicula Spencerii.—Early in the present year, Mr. Matthew Marshall received some specimens of this species from Professor Bailey, of West Point, New York, who stated that an object-glass, constructed by a young artist of the name of Spencer, living in the back woods, had shown three sets of lines on it, when other glasses of equal power, made by the first English opticians, had entirely failed to define them. Mr. Marshall was supplied with the identical specimens on which Mr. Spencer's object-glass had been tried; these have since been carefully examined by Mr. Marshall and Mr. Warren De La Rue, and the nature of the markings clearly made out. Mr. De La Rue, has obligingly furnished the author with Plate IX., in which he has faithfully delineated a specimen of *N. Spencerii*, as viewed under a power of 800 diameters, and a portion of the same magnified 1,900 diameters, from which it will be plainly seen that the lines discovered by Mr. Spencer are in reality dots, and arranged so as to exhibit both transverse, longitudinal, and even oblique striae, when viewed by an object-glass not capable of separating the dots one from the other. Mr. De La Rue has further made out that the dots are not projections from the surface, but are either perforations or depressions. The shape of the shell is not unlike that of a small kind of *N. Hippocampus*, which the markings also very much resemble.

Nobert's Tests.—M. Nobert, of Greifswald, having occupied himself for some years in the manufacture and the testing of a large compound microscope, discovered that the productions of nature, which had been almost exclusively used as test objects, were more or less different in the nature and arrangement of their markings, hence he was led to the employment of such objects for comparison as can be reduced to number and measurement, as modern philosophy requires in all its parts. The plan adopted by M. Nobert, is to etch on glass ten separate bands at equal distances from each other, each band is composed of parallel lines of some known fraction of a Prussian inch part; in the first band they are $\frac{1}{1000}$, and in the last $\frac{1}{4000}$ of the same quantity, whilst the eight intermediate groups, with regard to the distance of their parallel lines,

form parts of a geometric series, as represented in the following table:—

0 ^{'''} , 001000
0 , 000857
0 , 000735
0 , 000630
0 , 000540
0 , 000463
0 , 000397
0 , 000340
0 , 000292
0 , 000225

In order to render the subject more intelligible, the author, through the kindness of his friend, Dr. J. Hughes Bennett, has been enabled to give the following representations of M. Nobert's truly wonderful productions. Fig. 236 exhibits a piece of glass of the same size as the original, on which in the centre are ruled the ten bands or clusters of lines before alluded to, the entire number occupying so small a space as the one-fourth of a line; when this glass is placed

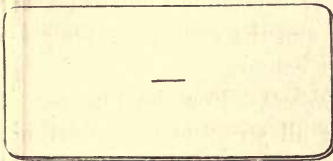

Fig. 236.

under a magnifying power of about 100 diameters; the bands containing the fewest number of lines in them will present the appearance shown by fig. 237, in which are exhibited the lines as seen in four of the

coarsest, the other six with so low a power not being visible, and even those in the fourth band requiring some care in the il-



Fig. 237.

lumination to define them satisfactorily. In order to use this test, the bands are viewed by glasses of different focal lengths, in the same manner as any other lined objects, and

the number of the bands with their lines clearly defined, will

form a good criterion of the merits of any magnifying power from 100 to 2,000 diameters. Thus, for instance, if a quarter of an inch object-glass be employed with the best illumination, nine of the bands may be seen, and the lines in seven of them clearly defined, but still no trace of the tenth band visible; if, however, a twelfth be used, the lines in the tenth may be shown; and these, although the $\frac{1}{46,008}$ of an English inch apart, are as perfectly etched as those in the first band, which are four times as coarse as those in the tenth. Of all the tests yet found for object-glasses of high power, this would appear to be the most valuable, and one which comes very near to the utmost limit that the position of a line can be accurately ascertained. M. Nobert's paper is published in *Poggendorf's Annalen* for 1846; but as it would be foreign to the object of this work to enter so scientifically into the explanation of the reasons for adopting so valuable a form of test glass as M. Nobert has done, the reader is referred to the paper itself, which will well repay an attentive perusal, as the information it contains is of the highest practical importance. Accompanying the test kindly lent to the author by Dr. Bennett, was another glass, on which were etched in a similar manner a series of lines, the $\frac{1}{400}$ of a millimetre apart; these were, likewise, beautifully ruled, and the surface of the glass presented a rich play of iridescent colours.

Method of Examining Test Objects.—For the purpose of examining these most delicate of all structures, considerable care and skill are required, the more so if two object-glasses of equal power are to be tried one against the other. The usual modes of illuminating transparent objects have already been given at page 170, where also will be found the description of the different kinds of apparatus that are placed beneath the stage, in order to increase the brightness, or cut off the outer rays of the illuminating pencil. The objects for examination should be perfect specimens, and mounted either in the manner represented by figs. 190-1-2-3, or on a slide of the usual size, and covered with the thinnest films of glass; some of the most opaque specimens may be put up in balsam, but the majority are far better seen when mounted in the dry

way between pieces of thin glass. Day light will be found to be the best for all examinations, and the light reflected from a white cloud, save that of the sun, the brightest that can be obtained. The microscope having been placed on a firm table, in a suitable situation to get a good light on the mirror, and everything ready, the object-glass, if of high power, must next be corrected for the thickness of the glass cover; as the method of doing this was not described at page 159, it will be proper to mention it here.

Method of Using the Adjusting Object-glass.—As the high powers of Messrs. Powell and Ross have the same kind of adjustment, the following directions, drawn up by Mr. Ross, will answer for both; but those of Mr. Smith being of a different construction, will require a separate mention:—

“When an achromatic object-glass for a microscope has its aberrations corrected for viewing an uncovered object, the correction will be nearly the same, whether the object is seen by the light reflected from its surface as an opaque, or by its intercepting transmitted light as a transparent one, if these objects are properly prepared and illuminated. But if it be necessary to cover the object with glass or talc, or to immerse it in a fluid, the aberration caused by the refractive and dispersive power of the interposed medium deteriorates the performance of the object-glass.

“The adjustment which is given to object-glasses of high magnifying power, and transmitting large angular pencils of light, is for the purpose of compensating the aberration resulting from the various states in which an object may be placed. To effect this there are two lines on the external part of the object-glass; against the upper line is engraved *uncovered*, and against the lower, *covered*; there is also a small square piece of brass, or tongue, screwed into a morticed hole, with a single line upon it, as shown in fig. 238.

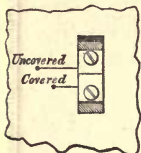

Fig. 238.

Immediately above the lines is a projecting milled edge, which may be moved independently of the other part of the object-glass, giving motion to the part marked *uncovered* and *covered*; so that either of the lines may be made

to coincide with that on the tongue. This motion has the effect of separating, or bringing nearer together the lenses which compose the object-glass. When the line against which *uncovered* is engraved coincides with that on the tongue, the adjustment is perfect for viewing an opaque or uncovered object; but when the line against which *covered* is marked coincides with that on the tongue, the object-glass is in adjustment for viewing an object covered with glass or talc one-hundredth of an inch thick. If the glass or talc is less than one-hundredth of an inch thick, then the mark on the tongue should be between the marks covered and uncovered; and if it exceed one-hundredth, then the mark on the tongue should be without the mark against which covered is engraved. This adjustment must be tested experimentally by moving the milled edge, so as to separate or close together the combinations, and then bringing the object to distinct vision by the screw adjustment of the microscope. In this process the milled edge of the object-glass will be employed to adjust for character of definition, and the fine screw movement of the microscope for correct focus."

The object-glasses of high power, constructed by Messrs. Smith and Beck, have the tube of their front lens moveable, and furnished with a screw collar, the circumference of which is engraved with ten divisions, numbered from 0 to 9; this, and the graduation on the milled head for slow motion, give a means of obtaining the finest performance under various circumstances. The following directions are thus given for their use:—

1. When the tube in the body of the microscope is not at all drawn out.

If the object is *uncovered*, screw up the collar of the object-glass, till 0 stands opposite to the vertical mark on the tube, its two or more horizontal marks, each of which indicates one revolution of the collar, being all fully exposed. (This is nearly as far as the screw will go without strain.)

If the object is *covered* with glass or talc, measure the thickness of this, taking advantage of dust or spots on the surfaces, by the milled head for slow motion: it has its circle

divided like the collar of the object-glass from 0 to 9; every revolution being ten divisions.

Multiply the number of divisions indicating the thickness by 0.7, if the $\frac{4}{10}$ inch object-glass is used; by 0.9 if the $\frac{1}{4}$ inch. Then set the collar to the number that is the product, screwing it *down* from its former position, and pressing up the tube of the front lens; and the adjustment is made.

2nd. When the tube in the body is drawn out, increase the number to which the collar is set, with the $\frac{4}{10}$ inch glass as under:—

For 1 inch drawn out add 2.5 divisions.				
2 inches	4	ditto.
3 ditto	5	ditto.
5 ditto	6	ditto.

The $\frac{1}{4}$ inch glass is little changed by lengthening the tube, but one division may be added for each of the first four inches drawn out.

* * The milled head for slow motion gives for the depth of $\frac{1}{10}$ of an inch in air fifteen divisions, in glass ten nearly.

In order to test the merits of an object-glass, an object suitable to its power should be employed; if below the half-inch no achromatic condenser need be used by day; the light from a white cloud may be reflected by the mirror, or that from an argand lamp at night; direct rays should be first employed, and the object brought well into focus; if it be a lined one, the concave mirror should be turned in various directions, in order that the lines may be distinctly seen; but the light should not be too oblique, as then fallacious appearances may be produced; if the achromatic condenser be required, the plane mirror should be used; and when the object is in focus, the illuminating lens should be moved up or down gently, to see at what point the definition is the best. If the power to be tested be an eighth or a twelfth, and the object a very minute one, a half-inch should be first used to find it out and bring it into the centre of the field, the high power may

then be substituted for the lower one; and if the axes of the two glasses coincide, the object will be found in the centre of the field, or very near it. It is always a tedious matter to find a minute object in a slide with a high power, unless a small circle be marked around it; but in practice it will be found most convenient first to examine the slide with a half-inch or inch, and to bring into the centre of the field of view the object required. Mr. Gillett adopts a very excellent method; he searches over all the objects contained in a slide, and paints a circle around the best specimens, and makes an enlarged drawing or chart of the slide on paper with all the circles, and within each circle a magnified representation of the objects contained in it; if the slide and the chart be compared, the circle within which the best specimens are contained can be placed in the field of view without much difficulty.

In testing the merits of any two glasses of equal power, the same illumination and object should be employed with each, and the only way of getting a measure of their relative value is to select a test that can be resolved by both, and that glass which shows the lines darkest, and all elevations the most prominent, and the spaces between them the clearest, may be considered to perform the best. Particular care should be taken in the management of the illumination, so that the rays be not too oblique, as it often happens that projections are shown as depressions, and depressions as projections. Objects, the intimate structure of which it is difficult to define, should be examined by two or more observers, especially such as the *Navicula hippocampus* and *angulata*, in which an appearance of lines is given by dots or projections, arranged in parallel rows, or in rows alternating with each other; nothing can more plainly illustrate the importance of this proceeding than figs. 2, 4, 5, in Plate VIII.; a number of persons have carefully examined these under the power by which they were drawn, and have set down on paper what they believed the markings to be produced by; some have declared them to be lines, whilst others, whose eyes were more practised, could resolve each line into a series of dots or elevations, as shown in figs. 3 and 7. The representations of the several test objects

given in Plates V., VI., VII., VIII., and IX., will form an excellent guide to the amateur, as to the amount of definition that a good object-glass of equal magnifying power to that employed in any given drawing should exhibit, as every specimen has been carefully sketched by the camera lucida, and all the markings put in as they were best seen, with glasses of great or small angles of aperture, the former exhibiting them as dots, the latter as lines.

CHAPTER XXI.

MISCELLANEOUS HINTS ON THE MANAGEMENT OF THE MICROSCOPE AND MICROSCOPIC PREPARATIONS.

Apartment.—In the choice of a room for microscopic observation, one on the ground-floor should be selected in which there is a window having a northern aspect, and not overshadowed by trees or buildings; a firm table is required for placing the microscope on, and in order that the latter may be at all times ready for use, it should be covered over either with a glass or other shade when not employed; many valuable observations will be lost if the labour of packing and unpacking of the instrument and apparatus have to be frequently repeated. A glass shade, especially a stout one of the old make, with a knob at the top, will be found to keep off the dust as effectually as any well constructed box or case. Drawers and cupboards, for containing preparations in bottles and boxes, will be found very convenient. A small nest of drawers, fitted up under the table, will be useful for keeping thin glass covers, spare slides, cutting instruments, &c. In the winter, when fires are in use, it will be necessary to be careful to cover over any preparations that are about to be dried before being mounted, as small particles of carbon are continually being deposited in all situations; for this purpose small shades, such as are employed for raising young plants, will be found particularly convenient.

To Clean the Optical part of the Microscope.—In order to clean the glasses of the eye-piece, they should be unscrewed, and wiped either with a piece of clean lawn or wash leather; an old soft cambric handkerchief will be an excellent substitute for either. In the case of the object-glasses, the wiping should be conducted with great care; in the majority of instances, a camel's-hair pencil will remove any dust, but for all other purposes the leather or linen will be required. Some persons recommend that the wash-leather should be impregnated with putty or crocus powder; both this and the linen should be kept perfectly free from dust in a box, and employed for no other purpose.

Glass Slides may be freed from all grease by washing them with potash; the Rev. J. B. Reade has recommended an infusion of nut galls (which contains a large quantity of tannic acid) for the same purpose. In wiping the slides and the covers as well, be careful not to employ a substance likely to leave any nap or down behind, as coloured filaments, derived from table-covers, pocket-handkerchiefs, &c., have, more than once, been mistaken for highly organized structures.

Cabinets and Boxes for holding Microscopic Objects.—The slides generally employed by microscopists are of one of the sizes recommended by the Microscopical Society, viz., three inches by one, or three inches by one-and-a-half; the former is most commonly used. Any number of these may be cut of the required dimensions by the board and ruler described at page 242. Objects mounted on slides are often required to be carried about; for this purpose small boxes are used, the sides of which are provided with strips of wood, termed *racks*, having a series of grooves cut in them, at equal distances apart, to receive the ends of the slides; when the slides are placed in the grooves, they may be kept either in a horizontal or in a vertical position; some persons prefer the former, others the latter method. Boxes capable of containing one or two dozen objects can very well be carried in the pocket without injury, provided the cover be well padded and pressed firmly against the sides of the slides; others, made in the shape of books, and fitted up with racks, look very neat when

arranged on shelves, the objects contained in them should be kept in the horizontal position, which can readily be done by having the box made of sufficient breadth to contain one or two slides when placed horizontally. The chief inconvenience in this mode of arrangement is the difficulty of finding any required object quickly, hence it will be found in practice, where stowage room is not of much consequence, that the plan of keeping them in drawers perfectly flat will be by far the most advantageous; some persons prefer having the drawers divided into compartments, each one of which is only capable of holding a single slide, this, besides being an expensive plan, is not always necessary; if the cabinet be large, and not often moved, the divisions may be dispensed with; the author has kept for years a collection of anatomical preparations in shallow drawers, each being capable of holding nearly one hundred slides; no compartment of any kind is employed, and in no single instance has any injury befallen the specimens. The author of the work entitled *Microscopic Objects*, recommends the following as a convenient size for a fixed cabinet, where objects are required to be kept in a horizontal position, viz., "twelve inches long, nine inches wide (from front to back), and one quarter-of-an-inch deep. These are the inside measures of each drawer, which will contain thirty-six slides of the standard size; viz., three inches long and one inch wide. A cabinet of twenty shallow drawers of these dimensions, and four deep ones for opaque objects, will form an excellent museum, capable of containing nearly 2,000 specimens." The following plan of securing the slides in the drawers of a small moveable cabinet, having as many as twelve of the latter in a depth of four inches and a quarter, is also worthy of mention, the width of the drawers from front to back being six inches:— "Into these shallow drawers the slides containing the objects are laid flat in double rows; the outer ends of the slides are made to fit into a ledge in the front and back of each drawer; the inner ends of the slides, meeting in the middle of the drawer, are kept down by a very thin slip of wood covered with velvet. In this way the slides do not shake when the cabinet is moved from place to place; every object is

seen without removal, and thus no time is lost in making a selection."

Opaque objects mounted on discs should be kept in drawers or boxes lined with cork, and well protected from dust; each disc should have either a number or the name of the object written on it.

Labelling Slides, &c.—The methods of cutting and edging glass slides has already been given at pages 243-4. Those who employ plate-glass generally have the edges of their slides either ground or polished; but others, who prefer flatted crown, usually cover them with paper, which gives them a neat appearance. The slides that are protected with paper are generally those having objects on them mounted either in the dry way or in balsam; and when the paper is thin, like the common blue, it may often be laid on at one operation, a hole having been previously punched out of the centre of the top and bottom piece for the object. Mr. Topping and others employ green or blue coloured papers, on which some kind of pattern is printed in gold. These should be cut of the size of the slide, and a hole punched out of the centre of each for the object; strips of thin paper are then to be pasted around the edges, and the upper and under surfaces afterwards covered with the figured paper. Some persons stick white labels upon the coloured paper; but the most satisfactory method of proceeding, is to paste a piece of white paper upon one end of the slide, and to punch out a circular or other hole in the coloured paper that is pasted over it; by these means there is less risk of the label being lost, as it is doubly protected. When the slides are not papered, the name should be written on them by the diamond described at page 241; it will be often advisable, when fluid is used, to put down the name of it, and the date when the preparation was mounted. For the sake of cataloguing the slides, the opposite end to that having the name should be employed for the purpose.

APPENDIX.

Recent Improvement in the Stage of the Microscope.—Early in the present year, a paper was read at the Microscopical Society by Mr. Legg, on an improved stage for the microscope. In all the stages previously made, the revolving plate is placed above the horizontal and vertical movements, therefore, unless these movements are fixed, any object placed upon the revolving plate is certain to be lost to the field of view when this is turned on its own axis. To remedy this, Mr. Legg has changed the position of the revolving plate, and placed it below the other movements instead of above them. This is effected by attaching the revolving apparatus to the foundation plate of the stage by means of a strong dove-tailed or conical ring working freely but firmly in it; when in use, the revolving plate may be turned with the hand or by an endless screw; upon the ring, the plate having the stage actions is placed, these last are effected by milled heads seen on each side of the stage, the lateral motion consisting of a screw working in a collar connected with the sliding plate, and the vertical by a pinion fixed on the first sliding plate, and acting upon a rack on the under side of the top or object-plate; the whole is so contrived, as to traverse the entire extent of the circle and pass under the arm of the microscope without impediment. In fig. 239 is shown the stage as applied to a microscope constructed by Messrs. Smith and Beck; *a* represents part of the arm supporting the compound body *b*; *c* the fine adjustment; *d* the tube for carrying the object-glass; *ee* the milled heads of the stage actions (which are double, so that it matters not which side of the stage is nearest the arm *a*); *ff* the clips for securing the objects; *g* the ring which revolves upon the foundation plate *h*. When,

therefore, the object is fixed between the clips *ff*, it may be revolved, and, if the workmanship be correct, it will still be kept within the field of view, or only so much out, that the most trifling adjustment will bring it back to the centre.

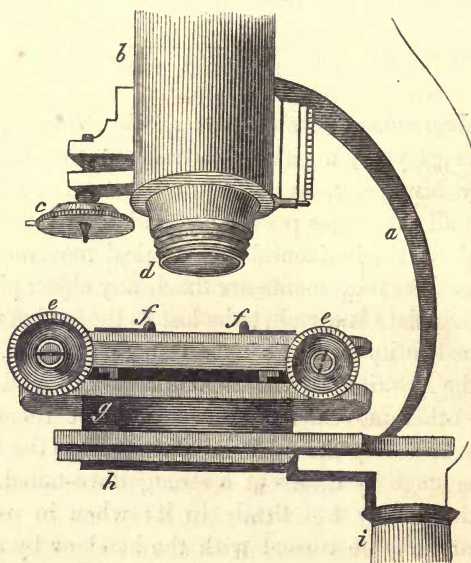

Fig. 239.

This contrivance Mr. Legg states is useful for examining crystals by polarized light, as well as lined objects, whether opaque or transparent, when it is desirable to cast a shadow in various directions without moving the illuminating apparatus.

Instrument for Cutting Circular Covers of Thin Glass.—At page 246, it was stated that oval or circular covers might be cut by a machine in which a plane surface of wood, on which the glass is laid, is made to revolve either in a circle or oval underneath a diamond point, or by a model of card-board or metal around which the writing diamond is to be passed. The little instrument represented by fig. 240, which has lately been contrived by Mr. G. Shadbolt, jun., to whom the author is indebted for the sketch, will be found to answer the purpose exceedingly well. It consists of a central stem of

steel wire *a a*, sliding freely in a tube of brass *b*. To the upper end of the wire is attached a disc of ivory *c*, and to the lower a small cylinder of box-wood *d*; to the lower end of

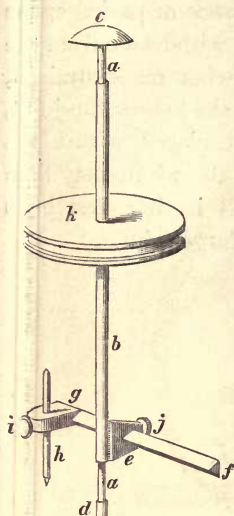

Fig. 240.

the tube *b* is fastened a piece of brass *e*, through which is made to slide a small triangular bar *f*, carrying at one end a semicircular piece of brass *g*, through which slides a steel pin *h*, armed with a diamond point; the pin may be fixed at any required height by the screw *i*, and the bar also, (when regulated for the size of circle to be cut) by the screw *j*. The use of the instrument is obvious, the cylinder *d* being placed in an upright position upon the piece of thin glass, and the arm *f* adjusted to the required size of the cover to be cut, a finger of the left hand is to be placed upon the disc *c*, and one of the right upon the edge of the larger disc of wood *k*; if this last be revolved, it will carry

with it the arm bearing the diamond, and a little practice will enable the operator so to regulate the pressure of the latter upon the glass, as to make a perfectly even cut. This instrument will be more fully described in Vol. II. of the *Transactions of the Microscopical Society*.

Improved Apparatus for Collecting Infusoria.—At page 353 was described an apparatus for securing a phial to the end of a stick, also an ingenious contrivance of Mr. Shadbolt; since the time, however, when he obligingly furnished the author with that description, he has much simplified the arrangement; the handle employed consists of two joints of a fishing-rod, as shown by fig. 231*a*; but instead of the upper ferrule being provided with a screw to receive the ring *b*, a piece of brass, having an oblong square hole *o* cut in it, is fastened into the ferrule, as shown in fig. 241 A C; through this the ends of a strip of whalebone are passed, and, according to the length inserted, the loop *r* may be made larger or smaller to receive the neck

of any kind of phial, the screw B serving to keep the whalebone so firm, that the weight of water in the phial may not draw the ends out of the brass.

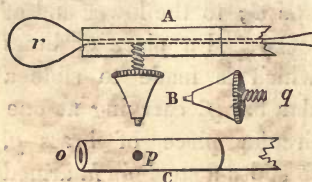
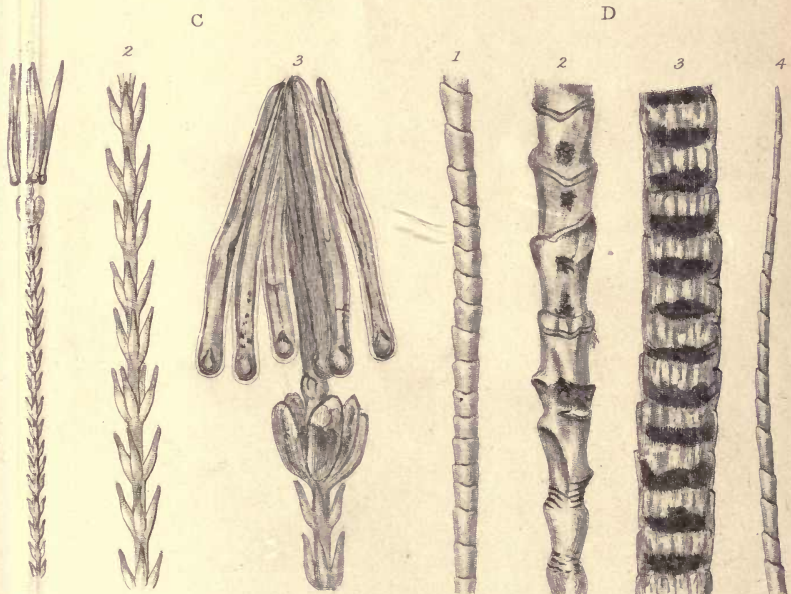
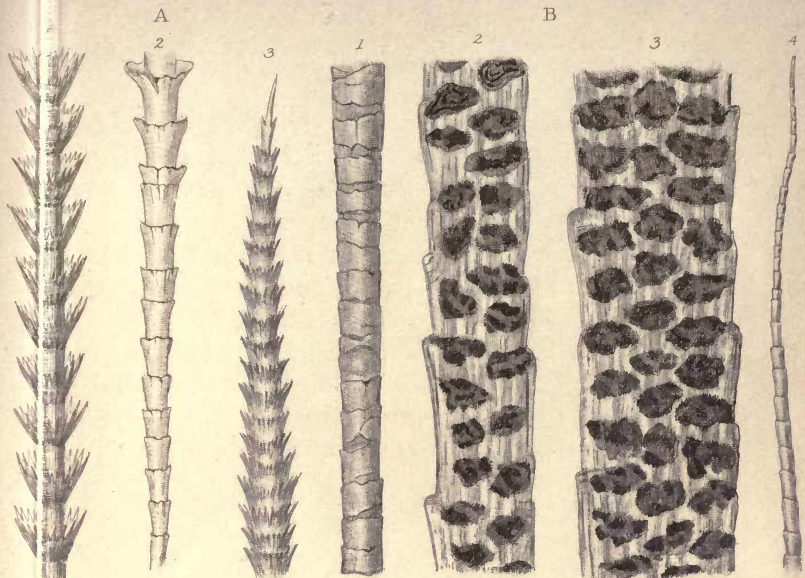

Fig. 241.

For convenience of package, the whalebone is withdrawn from the ferrule, and, when made straight, is slid within the hollow top-joint, and this last placed within the larger joint; the whole may then

be used as a walking stick, the screw B having first been properly secured in the lower end of the large joint.



S.W. Leonard del.

J.D.C. Sowerby sc.

A. Hair of Indian Bat.— 1, The Shaft. 2, Base. 3, Apex. Mag.^s 500 diam.
 B. Mouse Hair.— 1, Base. 2, 3, Intermediate portions. 4, Apex. 500 diam.
 C. Dermestes.— 1, 200 diam. 2, Shaft. 3, Apex, 500 diam.
 D. Mouse (small flat hair) 1, Base. 2, 3, Intermediate portions. 4, Apex. 500 diam.



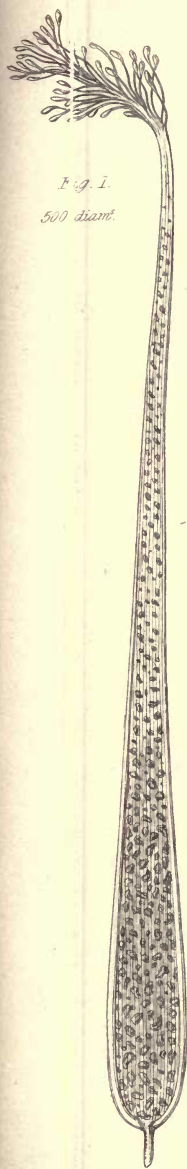

Fig. 1.
500 diam.

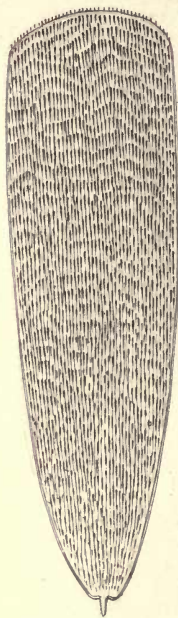

Fig. 5.

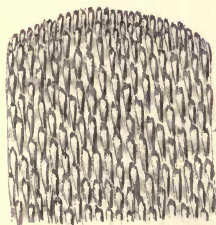

Fig. 4°

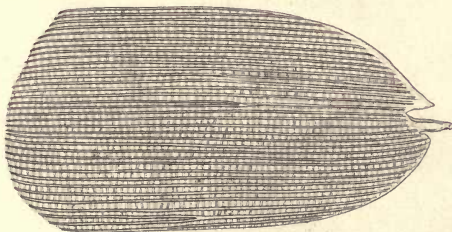

Fig. 3.

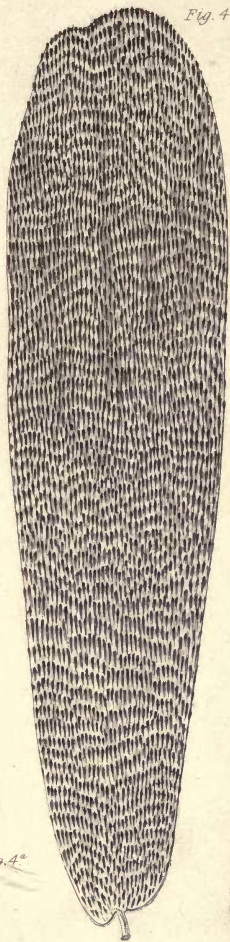

Fig. 4.



Fig. 2.
500 diam.

W. Leonard, del.

1

J.D.C. Sowerby

Fig. 1. Scale from *Hipparchia janira*.

Fig. 3. D°, from *Polyommatus argiolus*.

Fig. 5. A very small scale of *Podura plumbea*.

Fig. 2. Scale from *Podia brassica*. 1500

Fig. 4. Large scale from *Podura plumbea*.

Fig. 4°. Portion of the same magnified 1250 diam.

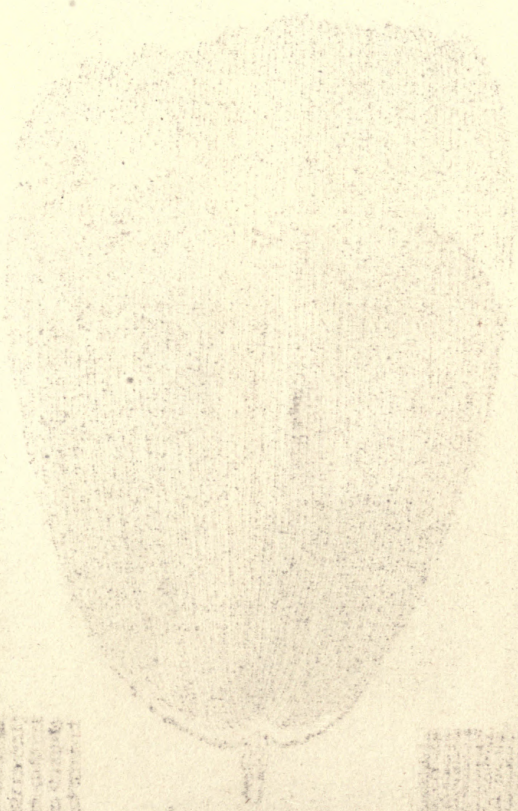

1875
JAN 10 1875
NEW YORK
LIBRARY OF THE
NEW YORK HISTORICAL SOCIETY
122 NASSAU ST. N.Y.C.

1875
JAN 10 1875
NEW YORK
LIBRARY OF THE
NEW YORK HISTORICAL SOCIETY
122 NASSAU ST. N.Y.C.

1875
JAN 10 1875
NEW YORK
LIBRARY OF THE
NEW YORK HISTORICAL SOCIETY
122 NASSAU ST. N.Y.C.

Fig. 1.



Fig. 2.



Fig. 3.

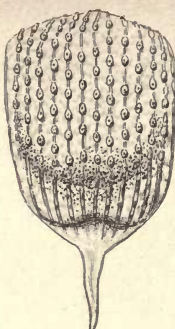

Fig. 4.

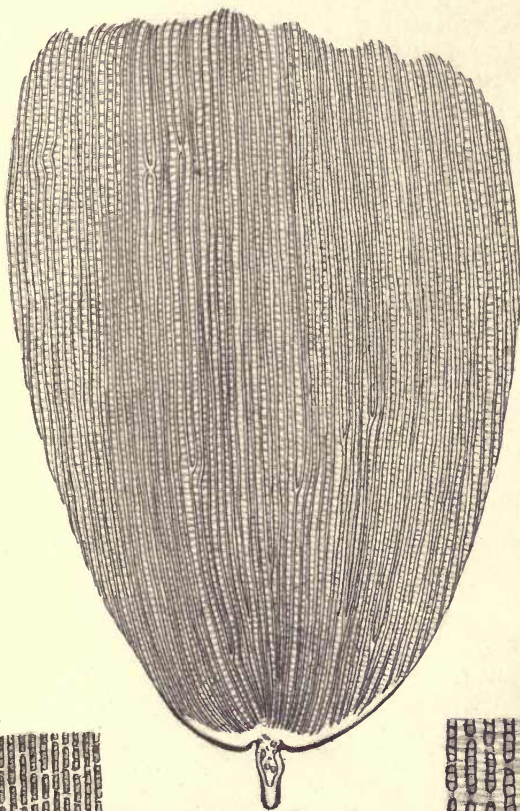

Fig. 5.

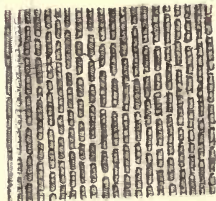

Fig. 6.

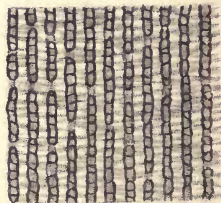

Fig. 7.



sonard. del.

J.D.C. Sowerby. sc.

- Fig. 1. 2. Scales from the wing of a Gnat, magnified 500 diameters.
- Fig. 3. Smal's scale from the *Polyommatus argolus* (Aureo-blue), magnified 500 diam.
- Fig. 4. Scale of *Morpho Menelaus*, magnified 500 diam.
- Fig. 5. A portion of Fig. 2, Plate 6, magnified 1200 diam.
- Fig. 6. A portion of coarse scale of *Pontia brassica*, magnified 1200 diam.
- Fig. 7. A portion of the scales of *Panparchia janira*, magnified 1200 diam.



Fig. 1.

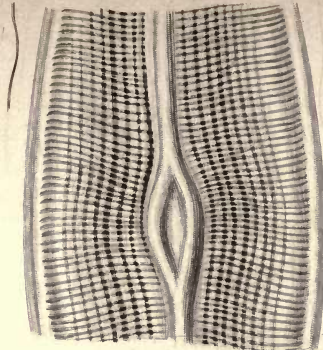
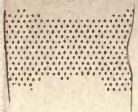

Fig. 1

600

Fig. 5.



1200

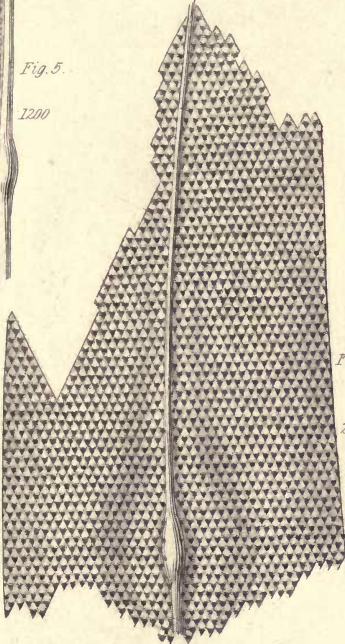

Fig. 6.

2000

Fig. 8.

500

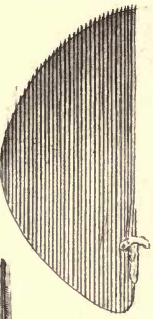

Fig. 11.

1200

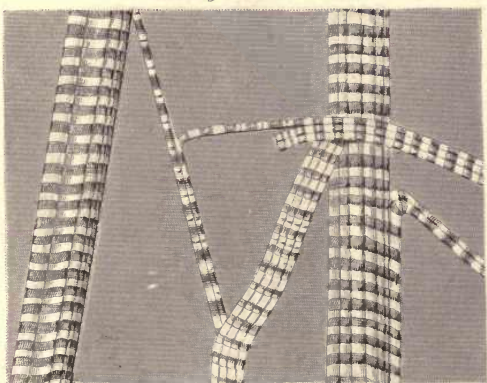

Fig. 12.



Fig. 10.



600

- 1. *Navicula hippocampus*, 600 diam^s
- 2. " " " " 1200 diam^s
- 3. Part of Fig 2 to show dots instead of lines.
- 4. *Navicula angulata*, 600 diam^s
- 5. " " " " 1200
- 6. " " " " 2000

- 7. Part of Fig. 5. to show dots instead of lines.
- 8. Half of a small scale of *Lepisma saccharina*, 500 diam^s
- 9. D^o of a large scale.
- 10. Part of a Muscular fasciculus of Fig. 600 diam^s
- 11. " " " " 1200 diam^s
- 12. Diagram to illustrate Fig. 11.

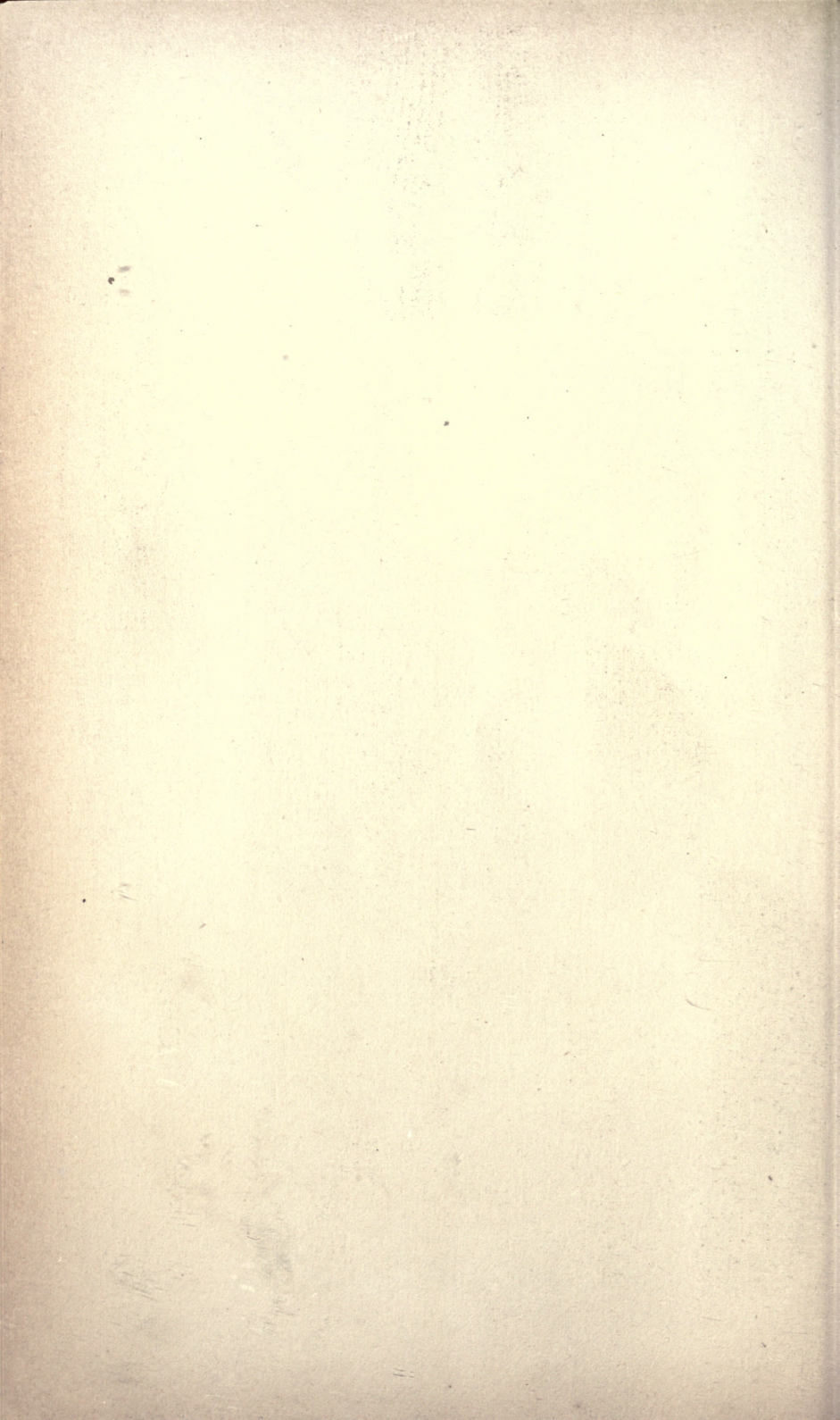

QUEKETT ON THE MICROSCOPE.

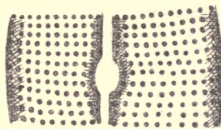

Magnified 1900 diameters.

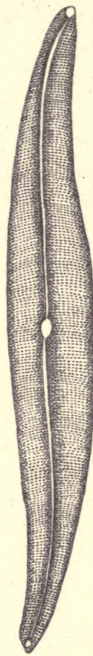

Magnified 800 diameters.

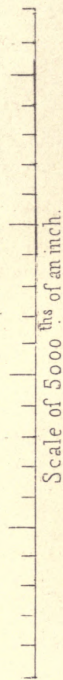

Distance between the Centres of the Spots.
 from $\frac{1}{45000}$ th. of an inch to $\frac{1}{50000}$ th. of an inch.

Navicula Spencerii.

INDEX.

A

- ABERRATION,
chromatic, 143
spherical, 143
- Acarus,
scabiei, 385
folliculorum, 385
autumnalis, 386
domesticus, 386
- Accessory instruments, 98
- Achromatism,
discovery of, 32
- Achromatic condenser,
Powell's, 101
Ross's, 101
Smith's, 103
- Achromatic microscope, 151
- Adams, George,
microscope of, 23
- Adams, George, jun.
microscope of, 24
micrometer of, 190
- Adjustment of light, 166
of focus, 167
- Advantages of polarized light, 230
- Æpinus,
microscope of, 34
- Alcyonium,
specimens of, 377
- Algæ, 374
- Amici,
reflecting microscope of, 26
achromatic object-glass of, 35, 39
- Angle of aperture, 426
method of measuring, 428
- Animal tissues,
to dissect, 324
classification of, 375
- Animal objects,
classification of, 375
- Animal structures,
to mount in Canada balsam, 280
- Animals,
hair of, 395
horns of, 397
hoofs of, 397
- Antennæ of insects, 380
- Apartment, choice of, 447
- Aphides, 384
- Apparatus,
polarizing, 104
for collecting infusoria, 352, 453

- Aquatic plants,
to cultivate, 349
- Aristophanes, 1
- Asphaltum cement, 267
- Author,
dissecting microscope of, 328
indicator of, 130

B

- BACON, ROGER, 2
- Baker,
work of, 21
- Background illumination, 178
- Basement membrane, 405
- Bat's hair, 432
- Blood,
circulation of to view, 332
in insects, 333
in fish, 335
in frog, 337
in mammalia, 341
specimens of in vertebrata, 388
- Bone,
specimens of, 389
sections of, to make, 297
to mount, 299
- Bonnani,
microscope of, 7
- Bonnet for compound body, 131
Lister's, 131
Leonard's, 132
- Bottle-holder, 127
- Box cells, 262
method of cementing, 265,
266
- Boxes for objects, 448
- Brewster, Sir David,
jewel lenses of, 26
grooved sphere of, 29
fluid object-glasses of, 34
- Built up cells, 260

C

- CABINETS FOR OBJECTS, 448
- Cages for animalcules, 114
- Camera lucida, 128
mode of constructing, 210
method of using, 212
uses to which applied, 213
method of making diagrams by,
214
- Campani, 6

- Canada balsam,
to mount objects in, 274
to mount sections of wood in, 278
to mount animal structures, 280
fossil infusoria, 281
foraminifera, 282
- Candlestick, 140
- Carmine,
to feed infusoria with, 362
- Cells,
flat, 253
E. J. Quekett's, 253
Darker's, 253
thin glass, 254
concave, 255
white lead, 256
Valentine's, 256
Holland's, 256
Topping's thin, 257
tube, 258
drilled, 259
built up, 260
box, 262
deep, to mount objects in, 262
Rainey's, 264
paper, 288
to mount opaque objects in, 293
method of cementing, 247
with and without heat, 248
with marine-glue, 248
with Canada balsam, 250
plate for, 248
apparatus for, 249
- Cellular tissue, vegetable, 367
- Cements,
japanner's gold-size, 267
sealing-wax varnish, 267
asphaltum, 267
Canada balsam, 268
diamond, 269
electrical, 268
marine-glue, 268
thick gum, 269
- Chamber, dark, 100
- Chara,
circulation in, 342
habitat of, 351
- Charles, M.,
lenses of, 34
- Cheese-mite, 386
- Chevalier,
microscope of, 36
achromatic object-glass of, 38
- Chimney of lamp, 137
to clean, 141
shade, 137
- Chippings of wood, 312
- Chromatic aberration, 143
- Circulation of blood,
to view, 332
in fish, 335
- Circulation of blood,
in frog, 337
in tongue of frog, 339
in mammalia, 341
- Circulation in plants, 341
to view, 343
in Chara, 342
in Groundsel, 347
in Hydrocharis, 345
in Nitella, 344
in Penstemon, 346
in Tradescantia, 346
in Valisneria Spiralis, 347
- Classification,
of objects, 366
of animal tissues, 375
- Cleaning lamps, 138
slides, 283
- Cobweb micrometer, 195
- Coddington lens, 48
- Collomia seeds, to view, 414
- Colours of polarized light, 225
- Compound microscope, 147
- Compound achromatic microscope,
67, 151
Varley's, 94
Dancer's, 97
Powell and Lealand's, 74, 77
large, 81
Ross's, 82, 85
Smith and Beck's, large, 88
smaller, 91
student's, 92, 93
stand, parts of, 68
object-glasses, 71
- Compound body,
method of mounting, 70
- Compressorium, 121
- Condenser,
Wollaston's, 100
achromatic, 101, 173
to use, 173
Powell's, 101
Ross's, 101
Smith's, 103
- Condensing lens, 106
small, 108
- Corals, list of, 379
- Corks loaded, 321
- Correction of object-glass, Ross's, 154
- Coventry,
micrometer of, 191, 209
- Covers of thin glass, 246
- Crystallization of salts to view, 412
- Cuff,
microscope of, 20
micrometer of, 22, 190
- Culpeper,
microscope of, 20
- Cultivation of water plants, 349
- Currents in fluids, to view, 413

- Custance,
 wood sections of, 24
 Cuthbert,
 reflecting microscope of, 35
 Cyticles,
 vegetable, 367
 siliceous vegetable, list of, 370
 Cutting-machine, 306
 Topping's, 309
 forceps, 316
 board for glass, 242
 method of using, 243
 Cylinders,
 mounting objects on, 292
 Cynips, 384
- D
- DANCER,
 microscope of, 97
 Dark chamber, 100
 stops, 112, 186
 Darker, Mr.,
 polarizing apparatus of, 230
 method, 289
 cell, 253
 Deep cells,
 to mount objects in, 262
 Dermestes, hair of, 433
 Desmidiæ,
 to collect, 358
 method of mounting, Mr.
 Thwaites's, 257
 Diamond,
 lens, 66
 cement, 269
 glazier's, 239
 writing, 241
 method of using, 240
 Diaphragm, 99
 French, 109
 Directions, preliminary, 165
 Direct light, 177
 Discs,
 to mount opaques on, 290
 Dissecting instruments, 314
 forceps, 314
 cutting forceps, 316
 microtome, 316
 needles, 319
 needle-holders, 320
 non-cutting, 320
 rests, 322, 325
 troughs, 320
 scalpels, 317
 scissors, 315
 spring scissors, 316
 Valentin's knife, 318
 Dissecting lens, 51
 Dissecting microscope,
 Powell's, 52
 portable, Smith's, 54
 Dissecting microscope,
 portable, Ross's, 55
 Slack's, 57
 Ross's, 59
 Valentine's, 60
 Smith and Beck's, 62
 Raspail's, 63
 Oberhauser's, 326
 Author's, 328
 Dissection,
 of nerve, 329
 muscle, 329
 animal tissues, 324
 vegetable tissues, 323
 tracheæ of insects, 330
 spiracles of insects, 331
 Divini Eustachio,
 microscope of, 5
 doublet of, 28
 Dolland,
 achromatic telescope of, 33
 Doublet,
 periscopic, Wollaston's, 28
 microscopic, Wollaston's, 30, 65,
 144
 Herschel's, Sir J., 29
 Draw tube, 69
 Drebbel, Cornelius, 2
 microscope of, 3
 Drilled cells, 259
 Dry method of mounting objects, 284
 Gillett's, 286
 paper cell, 288
 Ducts, vegetable,
 list of, 368
 Dutch rush,
 to prepare, 305
- E
- EDGING GLASS SLIDES, 244
 Eggs of insects, 380
 Electrical cement, 268
 Elytra of insects, 380
 Epithelium,
 scaly, 403
 prismatic, 403
 ciliary, 404
 method of viewing, 404
 classification of, 408
 Erector, 109
 Euler, experiments of, 33
 Eyes,
 parts of, 399
 of insects, 380
 Eye-piece,
 Huyghenian, 72, 152
 micrometer, 192
 to clean, 448

- F
- FEET OF INSECTS, 381
- Ferns, 372
spores of, 372
- Fibre,
woody, 368
muscular specimens of, 400, 401
white and yellow, 402
- Fibro cellular tissue, 368
- Fish,
circulation of blood in, to view,
335
apparatus for, 336
scales of, 393
troughs, 126
- Fishing tubes, 117
- Flat cell, 253
E. J. Quekett's, 253
- Fluids, preservative, 270
acetate of alumina, 270
chromic acid, 272
Goadby's, 270
glycerine, 271
solution of creosote, 271
spirit and water, 270
Thwaites's, 271
naptha, 273
salt and water, 272
general directions for using, 273
currents in, to view, 413
- Fluid to mount objects in, 251
- Focus, adjustment of, 166
- Fontana, 2
- Foraminifera, to mount, 282
- Forceps, 112
Varley's, 119
E. J. Quekett's, 120
dissecting, 314
cutting, 316
for holding pill boxes, 296
Page's, 276
metal, 277
- Fossil,
Infusoria, 363
method of preparing, 364
list of, 376,
to mount, 281
teeth, specimens of, 391
woods, list of, 370
- Fraunhofer,
object-glass of, 35
- French diaphragm, 109
lamp, 135
- Frog,
circulation of blood in, 337
tongue of, circulation in, 339
bit, circulation in, 345
plate, 125, 337
- Fuss, Nicholas, work of, 33
- G
- GILLETT, MR.,
Method of mounting objects dry,
286
- Glass,
best for microscopic purposes, 242
cutting board for, 242
method of cutting slides, 243
thin, method of cutting, 245
thin, covers of, 246, 452
- Glazier's diamond, 239
- Goadby, Mr.,
dissecting microscope of, 58
fluid of, 270
- Goniometer,
Leeson's, 231
Ross's, 235
- Gorgonia, specimens of, 378
- Goring, Dr.
lenses of, 26
improvement in reflecting mi-
croscope, 35
test objects, discovery of, 38
- Gray, Stephen,
lenses of, 9
water microscope of, 10
simple reflecting microscope of,
10
fluid lenses of, 11
- Grindelius, microscope of, 8
- Groundsel, circulation in, 347
- Guano, to prepare, 365
- Gum cement, 269
- Glycerine, 271
- H
- HABITAT,
of Chara, 351
Nitella, 351
Hydrocharis, 351
- Hairs, 313
of animals, 395
of bat, 432
of insects, 381
of mouse, 432
of dermestis, 433
of plants, 370
- Hall, Chester More, Mr.,
object-glass of, 32
- Harvest bug, 386
- Herschel, Sir J.,
doublets of, 29
- Hill, Dr.,
work of, 24
- Hints, miscellaneous, 447
- Holder, bottle, 127
needle, 320
- Holland, Mr.,
triplet of, 31, 65, 146
white lead cell of, 256

Hood, for compound body, 131
 Lister's, 131
 Leonard's, 132
 Hoofs of animals, 397
 Hooke, Robert, 3
 micrographia of, 3
 microscope of, 4
 Horns of animals, 397
 to make sections of, 313
 Huyghens, 2
 Huyghenian eye-piece, 152, 160
 Ramsden's improvement on,
 160
 Hydras, to examine, 356
 Hydrocharis, circulation in, 345

I

ILLUMINATION,
 of objects, 170
 transparent ditto, 170
 background, 178
 Indicator, 130
 Infusoria, 352
 to procure, 352
 localities for, 352, 360
 apparatus for collecting, 352, 453
 method of collecting, 354
 wheel, 362
 to feed with carmine, 362
 fossil, 363
 method of preparing, 364
 to mount in Canada balsam, 281
 fossil, list of, 376
 recent, list of, 375
 Injections, Lieberkuhn, 17
 of mucous membranes, 408
 Insects,
 circulation of blood in, 333
 trachea of, to dissect, 330
 spiracles of, to dissect, 331
 preparations from, 279
 antennæ, 380
 eggs of, 380
 elytra, 380
 eyes of, 380
 feet of, 381
 hairs of, 381
 mouth of, 382
 parasitic, 383
 itch, 385
 scales of, 386
 spiracles of, 387
 tracheæ of, 387
 stings of, 387,
 stomachs of, 388
 miscellaneous parts of, 388
 Instruments,
 dissecting, 314
 for cutting covers, 452
 non-cutting, 320
 Iron plate, for cells, 248

J

JACKSON, MR.,
 micrometer of, 193
 Jansen, Zacharias, 2
 Japanners' gold-size, 267
 Jatropha oil, 138

K

KING, MR.,
 experiments of, 224
 Knife, Valentin's, 318

L

LAMP,
 French, 135
 reading, 133
 shade, 134
 to clean, 138
 chimney to clean, 141
 spirit, 278
 Leeson, Dr.,
 goniometer of, 231
 Legg, Mr.,
 experiments of, 221
 stage of, 451
 Leeuwenhoek,
 microscope of, 6
 Lens, method of making, 5
 watchmakers, 50
 dissecting, 51
 single, 64
 doublet, 65
 diamond, 66
 condensing, 106
 jewel, Sir D. Brewster's, 26
 Mr. Pritchard's, 27
 doublet, Divini's, 28
 Goring's, Dr., 26
 periscopic doublet, 28
 Charles's M., 34
 Coddington, 48
 Stephen Gray's, 9
 fluid, Stephen Gray's, 11
 Leonard, Mr.,
 condensing lens of, 108
 hood for compound body, 132
 Lever stage,
 Alfred White's, 89
 Lieberkuhn, 110
 to illuminate by, 183
 solar microscope of, 14
 opaque microscope of, 15
 hand microscope of, 16
 injections of, 17
 anatomical injections of, 18
 Light,
 adjustment of, 166
 direct, 177
 oblique, 178
 polarization of, 215

- Limpet, tongue of, 418
 Lines,
 micrometer, value of, 198
 eye-piece micrometer, value of, 200
 Lister, Mr.,
 achromatic microscope of, 36
 improvement in object-glass, 39
 object-glass, 149
 Loaded corks, 321
 Localities,
 for Chara, 351
 for Infusoria, 360
 for wheel animalcule, 362
 Lucernal microscope, 24
 Lucida camera, 128
- M
- MACHINE CUTTING, 306
 Mr. Topping's, 309
 Magnifying powers,
 Hook's method to obtain, 207
 linear measure, 205
 superficial measure, 205
 table of, 208
 Mammalia,
 circulation in, 341
 Manipulation, 239
 Marine-glue, 248, 268
 Marshall,
 microscope of, 13
 Martin, Benj.,
 microscope of, 13
 Measurement of objects,
 with micrometer eye-piece, 198
 with stage micrometer, 197
 obtained by camera lucida, 203
 French table of, 210
 Membrane, basement, 405
 Mercury biniiodide, 417
 Micrographia,
 Hooke's, 3
 Micrometer, 189
 Adams's, 190
 cobweb, 195
 cobweb, to use, 203
 Cuff's, 22, 190
 Coventry's, 191, 209
 eye-piece, 192
 eye-piece, to use, 202
 Jackson's, 193, 199
 Martin's, B., 190
 Ross's, 192
 stage, 191
 Micrometer lines, to find value of,
 in cobweb micrometer, 201
 in eye-piece micrometer, 200
 in stage micrometer, 198
 Microscope,
 definition of, 1
 Adams's, George, 23
- Microscope,
 Adams's, George, jun., 24
 Amici's reflecting, 26
 anatomical, Lieberkuhn's, 18
 Æpinus's, 34
 Bonnani's, 7
 Culpeper's, 20
 Cuff's, 22
 Chevalier's, 36
 Cuthbert's reflecting, 35
 Divini's, 5
 Drebbel's, 3
 Gray's, Stephen (water), 10
 Gray's, Stephen (reflecting), 10
 Grindelius's, 8
 Hooke's, 4
 hand, Lieberkuhn's, 14
 opaque, Lieberkuhn's, 15
 Leeuwenhoek's, 6
 lucernal, 24
 Marshall's, 13
 Martin's, 22
 Newton's, Sir Isaac, 9
 solar, Lieberkuhn's, 14
 Salvetti's, 6
 Scarlett's, 20
 Wilson's, J., 12
 Wilson's, J., opaque, 12
 Wollaston's, Dr., 30
 compound, 147
 compound achromatic, 151
 Dancer's, 97
 Powell and Lealand's, 74, 77
 Powell and Lealand's, large, 81
 Powell and Lealand's, portable, 79
 Ross's, 40, 82
 Ross's portable, 85
 Smith and Beck's, large, 88
 Smith and Beck's, smaller, 91
 Smith and Beck's, for students, 92, 93
 Varley's, 94
 improvements in, by H. Powell, 43
 J. Smith's, 44
 improvements in, by C. Varley, 44
 parts of stand, 68
 use of, 162
 number manufactured, 46
 pocket, 48
 simple, 47
 simple, magnifying powers of, 65
 eye-pieces of, 72
 object-glasses of, 71
 Dissecting,
 Author's, 328
 Goadby's, 58
 Oberhauser's, 326
 Powell and Lealand's, 52

- Microscope,
 Dissecting,
 Ross's, portable, 55
 Ross's, 59
 Raspail's, 63
 Smith and Beck's, 62
 Slack's, 57
 Valentine's, 60
 Microscopic objects,
 classification of, 366
 algæ, 374
 animal objects, 375
 ducts, 368
 ferns, 372
 fibro-cellular tissue, 368
 hairs, 370
 hard tissues, 373
 cheese mite, 386
 mosses, 373
 mouth of insects, 382
 raphides, 372
 seeds, 371
 specimens of muscular fibre, 400
 siliceous cuticles, 370
 spiral vessels, 368
 spores of ferns, 372
 vegetable cuticles, 367
 vegetable cellular tissue, 367
 woods, sections of, 369
 woods, fossil, 370
 Microtome, 316
 Minerals, specimens of, 416
 Mirror, 73
 steel, 129
 Miscellaneous objects, 374
 Morbid structures to examine, 420
 Mounting,
 animal structures, 280
 foraminifera, 282
 fossil infusoria, 281
 sections of wood, 278, 312
 Mounting objects in Canada Balsam,
 274
 metal forceps for, 277
 necessary apparatus for, 275
 Page's forceps for, 276
 Mounting objects in the dry way, 284
 Darker's method, 289
 Gillett's method, 286
 Mounting opaque objects, 290
 in cells, 293
 on cylinders, 292
 on discs, 290
 in pill boxes, 295
 on slides, 293
 Mouse hair, 432
 Movement stage, 69
 Mucous membrane, 402
 method of examining, 406
 injections of, 408
 Muscle, to dissect, 329
 classification of, 401
- N
- NAVICULA ANGULATA, 438
 hippocampus, 438
 Spencerii, 440
 Needle,
 point, 277
 dissecting, 319
 holders, 320
 Nerve,
 to dissect, 329
 Newton, Sir Isaac,
 reflecting microscope of, 9
 Nitella,
 circulation of, 344
 habitat of, 351
 Nobert's tests, 440
 Non-cutting instruments, 320
- O
- OBERHAUSER,
 dissecting microscopes of, 326
 Objects,
 classification of, 366
 measurement of, 197
 vegetable, list of, 367
 miscellaneous, 374
 animal, 375
 transparent, to view, 166
 opaque, 169
 illumination of, 170
 test, 422
 transparent, to illuminate, 170
 opaque, to illuminate, 180
 method of mounting, 290
 to mount in fluid, 251
 apparatus for, 252
 to mount in Canada balsam, 274
 necessary apparatus for, 275
 to mount in flat cells, 253
 thin glass cells, 254
 concave cells, 255
 white lead cells, 256
 in the dry way, to mount, 284
 Mr. Gillett's, 286
 Mr. Darker's, 289
 for polarized light, 410
 Object-glass,
 achromatic, Chester More
 Hall's, 32
 fluid, Sir D. Brewster's, 34
 achromatic, Amici's, 35
 Fraunhofer's, 35
 Tulley's, 36, 148
 achromatic, Chevalier's, 38
 Amici's, 39
 improvement in, J. J. Lister's,
 39, 149
 improvements in, ditto, by A.
 Ross, 41
 of microscope, 71
 correction of, 154

- Object-glass,
triple, 41
method of adjusting, 443
to clean, 448
- Oblique light, 178
- Oil for lamps, 138
Jatropha, 138
- Opaque objects,
to illuminate, 180
method of mounting, 290
on discs, 290
on cylinders, 292
on slides, 293
in cells, 293
in pill boxes, 295
to illuminate by condensing
lens, 181
by condensing lens, Hooke's
method, 182
by side reflector, 183
by Lieberkuhn, 183
Sir D. Brewster's method, 187
- P
- PAGE'S FORCEPS, 276
- Paper cells, 288
- Parasitic insects, 383
- Penstemon,
circulation in, 346
- Phial-holder, 127
- Pill boxes,
to mount objects in, 295
forceps for holding, 296
- Plants,
hairs of, 370
circulation in, 341
Chara, 342
method of viewing, 343
Nitella, 344
Hydrocharis, 345
Groundsel, 347
Vallisneria spiralis, 347
Penstemon, 346
aquatic, to cultivate, 349
- Pliny, 1
- Pocket microscope, 48
- Podura, scales of, 435
- Point, needle, 277
- Portable, microscope, Smith, 54
Ross, 55
compound achromatic micro-
scope, Powell, 79
ditto, Ross, 85
lamp, 139
- Polarization of light, 215
origin of term, 215
apparatus for, 217
mode of using ditto, 218
advantages of, 230
cause of colours of, 225
Legg, Mr., experiments of, 221
King, Mr., experiments of, 224
- Polarization of light,
Darker, Mr., apparatus of, 230
objects for, 410
- Polarizing apparatus, 104
- Polyps, troughs for, 124
- Position of microscope, 165
- Powell, H.,
improvements in microscopes, 43
- Powell and Lealand,
compound achromatic micro-
scope, 74, 77
ditto ditto, large, 81
dissecting microscope, 52
achromatic condenser, 101
- Powers, magnifying, 142
- Preliminary directions, 165
- Preparations, animal, list of, 375
- Preservative fluids, 270
spirit and water, 270
acetate of alumina, 270
creosote solution, 271
Mr. Thwaites's, 271
glycerine, 271
chromic acid, 272
salt and water, 272
naphtha, 273
method of using, 273
- Prism, Dujardin's, 129
- Pritchard, A.,
jewel, lenses of, 27
works of, 45
- Ptolemy, 2
- Q
- QUEKETT, E. J.,
forceps, 120
flat cells, 253
method of mounting opaque
objects in pill boxes, 295
forceps for ditto, 296
- R
- RAINEY'S CELLS, 264
- Ramsden,
eye-piece of, 73, 160
- Raphides, 372
- Raspail, 63
- Reading-lamp, 133
- Re-agent, 168
- Record, 2
- Redi, Dr. Francis, 2
- Reflector, side, 111
- Rests, for dissecting, 322, 325
- Ross, Andrew,
first microscope of, 40
object glass of, 41
improvement in ditto, 41
compound microscope, 82
ditto ditto, portable, 85
dissecting microscope, portable,
55
single microscope, 59

- Ross, Andrew,
 achromatic condenser, 101
 correction of object-glass, 154
 goniometer, 235
- Rotifers,
 to procure, 362
- Rush, Dutch,
 to prepare, 305
- S
- SALTS,
 Crystallization of, 412
- Salvetti,
 microscope of, 6
- Scales,
 of fish, 393
 of Hipparchia Janira, 434
 of insects, 386
 of Pontia brassica, 434
 of Polyommatus argiolus, 434
 of Podura, 435
 of Lepisma, 436
 Gnat's wing, 436
 Menelaus, 437
- Scalpels, 317
- Scarlett,
 microscope of, 20
- Scissors,
 dissecting, 315
 spring, 316
 to sharpen, 317
- Sealing-wax varnish, cement, 267
- Sections,
 of bone, to make, 297
 teeth, to make, 301
 shell, to make, 302
 wood, to make, 306, 309
 hair, to make, 313
 horn, to make, 313
 vegetable tissue, to make, 304
 of wood, list of, 369
 wood, to mount, 278
 bone, to mount, 299
 teeth, to mount, 302
- Seeds,
 testa of, to view, 414
- Collomia, 414
 specimens of, 371
- Selenite stage, 411
- Seliges,
 experiments of, 36
- Seneca, 1
- Shadbolt, G.
 apparatus for infusoria, 352, 453
 instrument for cutting thin glass,
 452
- Shade,
 lamp, 134
 chimney, 137
- Shell,
 specimens of, 392
- Shell,
 sections, to make, 302
- Side reflector, 111
- Siliceous,
 vegetable skeletons, to prepare,
 305
 cuticles, list of, 370
- Simple microscope, 47
 magnifying powers of, 64
- Single lenses, 65
- Skin,
 specimens of, 397
- Slaak,
 dissecting microscope of, 57
- Slides,
 edging of, 244
 labelling of, 450
 method of cleaning, 283, 448
 mounting objects on, 293
- Smith, J.,
 microscope of, 44
 portable dissecting microscope,
 54
- Smith and Beck, 62
 achromatic compound micro-
 scope, 88
 ditto ditto, smaller, 91
 student's microscope, 92, 93
 achromatic condenser, 103
- Spherical aberration, 143
- Spider,
 circulation of blood in, 333
 wort, circulation in, 346
- Spiracles of insects, 387
 to dissect, 331
- Spiral vessels, 368
- Spirit lamp, 278
- Spores, of ferns, 372
- Spring scissors, 316
- Sponges, list of, 377
- Stage,
 movement, 69
 Legg's, 451
 ditto, Turrell's, 76
 lever, Alfred White's, 89
- Stand,
 compound microscope, parts
 of, 68
- Starch, 371
- Steel mirror, 129
- Stems, structure of, 311
- Stings of insects, 387
- Stomachs of insects, 388
- Stops, dark, 112, 186
- Structure of stems, 311
- T
- TABLE,
 of magnifying powers, 208
 French measures, 210

- Teeth,
specimens of, 391
fossil, specimens of, 391
sections of, to make, 301
ditto ditto, to mount, 302
- Telescope, Dollond's, 33
- Test objects, discovery of, 38
method of examining, 442
list of, 431
- Testa of seeds, to view, 413
- Tests, Nobeit's, 440
- Thwaites, Mr.,
method of mounting Desmidiæ,
257
- Tissues,
animal, to dissect, 324
vegetable, to dissect, 323
hard vegetable, to make sections of, 304
ditto ditto, list of, 373
- Tongue,
of Frog, circulation in, 339
of Limpet, 418
of Whelk, 418
- Topping, Mr.,
cutting-machine of, 309
troughs for dissecting, 320
thin cells, 257
- Tracheæ,
to dissect, 330
of insects, 387
- Transparent objects,
to view, 166
to illuminate, 170
- Triplet,
Holland's, 31, 65, 146
- Triple object-glass, 41
- Troughs,
for polyps, 124
for fish, 126
- Tube,
cells, 258
draw, 69
fishing, 117
- Tulley, Mr.,
object-glass of, 36
- U
- USE OF MICROSCOPE, 162
- V
- VALENTIN'S KNIFE, 318
- Valentine,
dissecting microscope of, 60
white lead cell, 256
- Vallisneria, circulation in, 347
to keep, 349
- Varley, Cornelius,
improvements in microscopes, 44
compound microscope of, 94
forceps, 119
- Vegetable,
sections of, to make, 304
skeletons, siliceous, to prepare,
305
cuticles, list of, 367
cellular tissue, 367
fibro-cellular tissue, 368
spiral vessels, 368
ducts, 368
- Vegetable tissue,
to dissect, 323
- Viviani, 3
- W
- WATCHMAKER'S LENS, 50
- Wells, dark, 111
- Whalebone, to cut, 318
- Wheel animalcule,
localities for, 362
- Whelk, tongue of, 418
- White, Alfred, lever stage, 89
- Wilson, J.,
microscope of, 11
opaque microscope of, 12
- Withering, Dr.,
microscope of, 25
- Wollaston, Dr.,
microscope of, 30
doublet of, 30, 65, 144
periscopic doublet of, 28
- Wood,
cuttings of, by Custance, 24
chippings of, 312
sections of, to make, 306, 309
ditto ditto, to mount, 278
sections of, list of, 369
- Woods, fossil, 369
- Woody fibre, list of, 368
- Woodward, Mr., work of, 227
- Writing diamond, 241
- Z
- ZAHN, JEAN,
work of, 8
- Zoophytes,
list of, 379

A. ROSS,

OPTICIAN,

2, FEATHERSTONE BUILDINGS, HOLBORN,

BEGS to call the attention of observers with the Microscope to his improved Instruments, a Catalogue of which may be had upon application.

Among the various advancements A. R. has effected is the extreme enlargement of the aperture of the MICROSCOPE OBJECT GLASS, which is its real effective improvement; also an Achromatic Condenser of Light for the Microscope, on a new combination of principles, for the illumination of transparent objects, adapted for use, with the several Object Glasses from $\frac{1}{2}$ an inch to $\frac{1}{18}$ of an inch focal length inclusive.

The object of this arrangement is to develop the defining powers of Object Glasses, and, by a peculiar adjustment, to adapt the illumination to the nature of the object and to the mode of mounting, whether dry or in fluid, or in Canada balsam, so as to admit a greater quantity of light with less glare, and, in consequence, to give a more distinct image with less fatigue to the eye. The Microscope Stand, or mechanical part, has also been arranged to ensure freedom from tremor and afford facility in use.

A. R. also begs to announce, that from a laborious practical investigation of the construction and manufacture of the Achromatic Astronomical Telescope, he has arranged a new process for their production, which ensures the perfection of that important instrument; also, that in Terrestrial and Naval Telescopes, the contact surfaces of the Object Glasses are united by a permanently transparent cement, which obviates the loss of light by reflections, and prevents that decomposition of the glass which generally occurs in Marine Telescopes.

Since the invention of those prospectively useful arts, the Calotype and the Daguerreotype, A. R. has investigated the forms of lenses necessary to give just representations of objects, and has succeeded in giving great intensity to the image with fine and correct definition, both at the centre and margin of the picture; also the visual and chemically acting foci are made to coincide.

A. R.'s Binocular Reading Glass prevents the fatiguing muscular exertion of the eyes attendant on the use of Spectacles of the ordinary construction, and preserves the eyes in repose during protracted application.

ASTRONOMICAL AND SURVEYING INSTRUMENTS.

BAROMETERS, HYGROMETERS, THERMOMETERS, &c. &c.

SMITH AND BECK,

No. 6, COLEMAN STREET, CITY,

LONDON.

	£	s.	d.
Best Compound Achromatic Microscope, on Double Pillar and Cones, Body with Quick and Slow Motions, graduated Sliding Tube, and 2 corrected Huyghenian Eye Pieces; Stage with Vertical and Horizontal Actions, given by Rackwork and Screw, or Lever, Sliding and Revolving Plain and Spring Clamping Piece, Large Double Mirror, Joint and Forceps, Brass Pliers, and 2 Glass Plates	16	16	0
Solid Spanish Mahogany Case for ditto, with Box for Apparatus and Drawers	3	10	0
Best Smaller Microscopes, on Single Pillar, with Actions same as above	12	12	0
Strong Solid Flat Case for ditto, with drawer	1	16	0
Student's Microscope with Uprights and Joints, Actions same as the above, 1 Eye Piece, and Mahogany Case included	9	9	0
The above, with Plain Stage, consisting of Sliding Piece and Clamping Spring, 1 Eye Piece, Concave Mirror, and other Actions, as above	5	10	0
Small Microscope for Travelling, with all the Actions to Stage and Body, 2 Eye Pieces, Double Mirror and Packing, in a Case 10 inches by 4½ inches, and 3¼ inches deep	10	10	0
The above, with Plain Stage	7	7	0
Plain Microscope for Hospital Use, with Quick and Slow Motions to Body, 1 Eye Piece, and packed in Mahogany Case	2	15	0

APPARATUS,	£	s.	d.	ACHROMATIC OBJECT GLASSES.	£	s.	d.
Extra Eye Piece, from 15s to	0	17	6				
Illuminator for Side Light, from	1	1	0	3 & 1½ in. Combination	4	0	0
Live Boxes, from... 6s. 6d. to	0	14	0	1½ in. alone	3	0	0
Achromatic Condensers, from	3	0	0	1¼ & ¾ in. Combination	4	4	0
Dark Wells and Fittings, from.....	0	12	6	¾ in. alone	3	3	0
Camera Lucida	1	0	0	⅔ in.	5	5	0
Micrometers	1	5	0	¼ in.	5	5	6
Polarizing Apparatus	2	10	0	⅛ in.	7	7	0
Compressor	1	0	0	⅙ in.	10	10	0
Erecting Glasses for Dissecting	1	0	0				

Achromatic Dissecting Microscope, with Power varying from 5 to 60 linear, and Apparatus complete, packed in a Mahogany Case	12	12	0
Darwin's Improved Single ditto, with 1 Doublet, 3 Single Lenses, and 3 Coddington ditto, Dissecting Apparatus, complete, and packed in a Case.....	10	0	0

MICROSCOPIC OBJECTS FROM 1s. 6d. EACH TO 5s.

Mahogany Cases for objects, with Arrangements for placing the Preparations Horizontally or in a Perpendicular Position, from 15s. to £5.

Glass Slips and Cells, Thin Glass, Canada Balsam, Gold Size, &c., for Mounting Objects.

Instruments for Cutting Discs of Thin Glass, Writing Diamonds.

Revolving Microscopic Tables, £5 5s.; Microscopic Lamps from £1 4s. to £1 8; Iron-work of Dredges for Deep Water Fishing, £1 5s.

Achromatic Telescopes, portable and mounted, for Astronomical Purposes.

BAROMETERS, THERMOMETERS, HYGROMETERS, ETC.

SPECTACLES, EYE GLASSES, HAND MAGNIFIERS, & CODDINGTON LENSES.

A FAMILIAR INTRODUCTION TO THE STUDY OF POLARIZED LIGHT, by CHARLES WOODWARD, F.R.S., &c.

C. M. TOPPING,

PREPARER OF MICROSCOPIC OBJECTS, &c.,

Begs to inform Scientific and Professional Gentlemen, and the Trade, that he has Removed from his late Residence in York Place, Pentonville, to No. 4, NEW WINCHESTER STREET, PENTONVILLE HILL.

N.B.—New Winchester Street is opposite my late Residence.

MEDICAL PORTRAIT GALLERY.

Under this Title, a Series of Portraits of

EMINENT LIVING MEDICAL MEN

IS IN COURSE OF PUBLICATION,

(Under the Superintendance of Mr. T. M. STONE, of the Royal College of Surgeons),

PRICE FIVE SHILLINGS.

Which will furnish to Students and Practitioners interesting memorials of their present or former Coadjutors or Teachers, and most important additions to the portfolios of Collectors.

The portraits already published have met with the highest eulogiums from the press, as will be seen from the appended extracts from the Medical Journals only.

Every care is used to render the Portraits as perfect as possible, and even as works of art they will be found of high value.

The Portraits are drawn on stone and printed on India paper at the smallest price which can be remunerative.

Those already published are Professors William Fergusson and R. B. Podd, M.D., of King's College, and J. F. South, Esq., of St. Thomas's Hospital. Those in course of publication are, Professor G. Budd, of King's College; Dr. John Forbes, late Editor of the British and Foreign Medical Review; J. H. Green, Esq., of St. Thomas's Hospital, &c.

“Striking and Spirited Portraits, the features and expression being correctly rendered. Valuable additions to the Medical Portrait Collector.”—*The Lancet*.

“Not only well executed as works of art, but excellent likenesses.”—*Medical Gazette*.

“Faithful likenesses of the distinguished originals.”—*Medical Times*.

H. BAILLIERE, 219, REGENT STREET.

A LIST

OF

ACHROMATIC MICROSCOPES & APPARATUS

MADE BY

J. B. DANCER,

Optician,

No. 43, CROSS STREET, MANCHESTER.

	£	s.	d.
Lecture Table Microscopes, with Rack Adjustments, 1 Eye Piece, Large Aperture, 1 inch (or $\frac{1}{2}$ inch Power), Plain and Concave Mirrors, with Japanned Iron Pillar and Tripod, from.....	4	10	0
Ditto ditto, with Brass Pillar and Tripod	5	5	0
Single Microscopes, from	2	2	0
An Improved Microscope with Double Pillars and Axis to incline the Instrument to any angle, Sliding Stage, Rack Motion, and fine Adjustment for the Powers, 1 Eye Piece, large Aperture 1 inch and $\frac{1}{2}$ inch (or $\frac{1}{4}$ inch), Powers, in Brass Boxes, Glass Condenser, with Jointed Support and Stand, Aquatic or Live Object Box, Forceps, Pliers, Knife Point and Brass Key, neatly packed in an upright polished Mahogany Case, with a Drawer... ..	10	10	0
<i>The following APPARATUS can be supplied to the above Microscope:—</i>			
Extra Eye Pieces, each	0	14	0
$\frac{1}{4}$ th inch Power Object Glass	2	10	0
$\frac{1}{4}$ th ditto ditto	3	3	0
Stage Movement, with Adjusting Screws	2	2	0
Polarizing Prisms (Mounted)	2	2	0
Achromatic Condenser	2	2	0
Camera Lucida (in Box)	1	1	0
Adjustable Compressor	1	1	0
Micrometer for the Eye Piece (in Box)	0	8	0
Ditto for the Stage..... from 5s. to	0	10	0
Mahogany Case, fitted with 6 additional Drawers.....	1	1	0
The largest size Instrument, including all the above Apparatus, packed in a Mahogany Cabinet with 7 Drawers.....	40	0	0

INJECTED MICROSCOPIC PREPARATIONS.

Mr. HETT, M.R.C.S.E.,

BEGS to inform Medical Gentlemen, and others engaged in Microscopic Researches, that he has for Sale a variety of SPECIMENS OF THE MOST BEAUTIFUL AND PERFECT INJECTIONS OF VARIOUS PARTS OF THE HUMAN BODY AND OTHER CLASSES OF ANIMALS.

Mr. HETT also prepares every variety of Microscopic object required to illustrate the more important and interesting facts of Minute Anatomy, Physiology, and Pathology.

Parties residing at a distance from London may have a Box of Preparations sent for inspection, on giving a respectable town reference, and paying carriage *both ways*; by this means they are enabled to examine the objects before purchasing, and to select such specimens only as they may require.

24, BRIDGE STREET, SOUTHWARK.

STANDARD SCIENTIFIC WORKS

PUBLISHED BY

HIPPOLYTE BAILLIÈRE, 219, REGENT STREET.

- BOUSSINGAULT.** RURAL ECONOMY; in its Relations with Chemistry, Physics, and Meteorology. By J. B. Boussingault, Member of the Institute of France. 2nd Edition, with Notes, carefully revised and corrected, 1 vol. 8vo. cloth boards, 18s. London, 1845.
- CAMPBELL.** A PRACTICAL TEXT-BOOK of INORGANIC CHEMISTRY, including the Preparations of Substances, and their Qualitative and Quantitative Analyses, with Organic Analysis. By Dugald Campbell, Demonstrator of Practical Chemistry to the University College, London.
- CHAPMAN.** A BRIEF DESCRIPTION of the CHARACTERS of MINERALS; forming a familiar Introduction to the Science of Mineralogy. By Edward J. Chapman, 1 vol. 12mo. with 3 plates, 4s. London, 1844.
- PRACTICAL MINERALOGY;** or, a Compendium of the distinguishing Characters of Minerals: by which the Name of any Species or Variety in the Mineral Kingdom may be speedily ascertained. By Edward J. Chapman. 8vo. illustrated with 13 engravings, showing 270 specimens, 7s. London, 1843.
- DUMAS AND BOUSSINGAULT.** THE CHEMICAL and PHYSIOLOGICAL BALANCE of ORGANIC NATURE: an Essay. By J. Dumas and J. B. Boussingault, Members of the Institute of France. 1 vol. 12mo. 4s. London, 1844.
- GORDON, L.** THE STEAM ENGINE, with every improvement to the present day. By L. Gordon, Professor of Engineering in the University of Glasgow. 8vo. Illustrated with Wood Engravings. *In the Press.*
- GRAHAM.** ELEMENTS of CHEMISTRY, including the Application of the Science in the Arts. By T. Graham, F.R.S.L. & E.; Professor of Chemistry at University College, London, 2nd edition, entirely revised and greatly enlarged, copiously illustrated with woodcuts. London, 1848. Parts I., II. & III. are ready.
** Part 6 and last of 1st Edition, containing Organic Chemistry, 8vo. 9s.
- HUMBOLDT.** KOSMOS: a General Survey of the Physical Phenomena of the Universe. By Baron A. Humboldt. The original English Edition, 2 vols. post 8vo. London. 1848. 1l. 2s.
** Vol. II. separately, 1848. 12s.
- KÆMTZ.** A COMPLETE COURSE of METEOROLOGY. By L. F. Kæmtz, Professor of Physics at the University of Halle. With Notes by Ch. Martins, and an Appendix by L. Lalanne. Translated, with Additions, by C. V. Walker, Editor of "The Electrical Magazine." 1 vol. post 8vo. pp. 624, with 15 plates, cloth boards, 12s. 6d. 1845.
- KNAPP.** CHEMICAL TECHNOLOGY, or CHEMISTRY applied to the Arts and to Manufactures. By F. Knapp, Professor at the University of Giessen. Edited, with numerous Additions, by Dr. E. RONALDS, Lecturer on Chemistry at the Middlesex Hospital; and Dr. THOMAS RICHARDSON, of Newcastle-on-Tyne. Illustrated with 500 large woodcuts. 2 vols. 8vo. London, 1848. Price 2l. 2s. Vol. II. separately, 21s.
- KNIFE.** GEOLOGICAL MAP of THE BRITISH ISLES; in a case. London, 1848. 4l. 4s.
- LIEBIG.** CHEMISTRY and PHYSICS, in relation to Physiology and Pathology. By Baron Justus Liebig, Professor of Chemistry at the University of Giessen. 2nd Edition, 8vo. 3s. London, 1847.
- MITCHELL, J.** MANUAL of PRACTICAL ASSAYING, intended for the use of Metallurgists, Captains of Mines, and Assayers in General. With a copious Table, for the purpose of ascertaining in Assays of Gold and Silver the precise amount, in Ounces, Pennyweights, and Grains, of noble Metal contained in one ton of Ore from a given quantity. 1 vol. post 8vo. London, 1846. 10s. 6d.
- TREATISE ON THE ADULTERATIONS OF FOOD,** and the Chemical Means employed to detect them. Containing Water, Flour, Bread, Milk, Cream, Beer, Cider, Wines, Spirituous Liquors, Coffee, Tea, Chocolate, Sugar, Honey, Lozenges, Cheese, Vinegar, Pickles, Anchovy, Sauce and Paste, Catsup, Olive (Salad) Oil, Pepper, Mustard. By J. Mitchell, F.C.S., Author of "Manual of Practical Assaying." 12mo. London, 1848. 6s.
- MULLER.** PRINCIPLES of PHYSICS and METEOROLOGY. By J. Muller, M.D. Illustrated with 530 woodcuts, and 2 coloured plates, 8vo. 18s. London, 1847.
- QUARTERLY** (The) Journal of the Chemical Society of London. Edited for the Society, by Dr. E. Ronalds, Lecturer on Chemistry at the Middlesex Hospital. Nos. I., II., III. 8vo. 1848. Each 3s.
- QUEKETT, J.** PRACTICAL TREATISE on the USE of the MICROSCOPE. Illustrated with steel and wood engravings, some of which are coloured. 8vo. London, 1848. 1l. 1s
- REGNAULT.** AN ELEMENTARY TREATISE ON CRYSTALLOGRAPHY, illustrated with 108 wood engravings, printed on black ground, 8vo. London, 1848. 3s.
- RICHARDSON.** GEOLOGY for BEGINNERS; comprising a Familiar Exposition of the Elements of Geology and its Associate Sciences, Mineralogy, Fossil Conchology, Fossil Botany, and Paleontology. By G. F. Richardson, F.G.S. 2nd Edition, post 8vo. with 251 woodcuts, 10s. 6d. 1843.

- RICHARDSON AND RONALDS.** METALLURGY; and the CHEMISTRY of the METALS: in 3 vols. 8vo. Illustrated with numerous wood engravings. *In the Press.*
- STARS AND THE EARTH.** THE STARS and the EARTH; or, Thoughts upon Space, Time, and Eternity. 3rd Edition, Seventh thousand, 18mo. 2s. London, 1847.
- THOMSON.** CHEMISTRY of ORGANIC BODIES — VEGETABLES. By Thomas Thomson, M.D. F.R.S. L. & E.; Regius Professor of Chemistry in the University of Glasgow, Corresponding Member of the Royal Academy of Paris. 1 large vol. 8vo., pp. 1092, boards. 24s. London, 1838.
- HEAT and ELECTRICITY. 2nd Edition, 1 vol. 8vo. Illustrated with woodcuts, 15s. London, 1839.
- THOMSON.** BRITISH ANNUAL and EPITOME of the PROGRESS of SCIENCE. By R. D. Thomson, Assistant Professor in the University of Glasgow, 3 vols. 18mo. cloth boards, lettered, 3s. 6d. each.

First Year, 1837.

Contains numerous Practical Tables of Weights, Measures, and Coins. The Popular Papers are by the Rev. B. Powell; C. Tomlinson, Esq.; W. S. B. Woolhouse, Esq.; T. S. Davies, Esq.; R. D. Thomson, M.D.

Second Year, 1838.

The Popular Papers are by T. Thomson, M.D., Regius Professor of Chemistry in the University of Glasgow; R. E. Grant, M.D. Professor of Comparative Anatomy in the University College, London; R. D. Thomson, M.D.; Life of James Watt, illustrated with a Portrait; H. H. Lewis, Esq.

Third Year, 1839.

The Popular Papers are by J. S. Russell, Esq.; Professor R. E. Grant; H. Garnier, Esq. R. D. Thomson.

- WEISBACH, J.** PRINCIPLES of the MECHANICS of MACHINERY & ENGINEERING. 8vo. 2 vols. illustrated with 900 wood engravings, 17. 19s. Vol. II. separately, 18s. London, 1848.

ANATOMY, MEDICINE, SURGERY, AND NATURAL HISTORY.

- CAMPBELL, J. S.** OBSERVATIONS on TUBERCULOUS CONSUMPTION; containing New Views on the Nature, Pathology, and Cure of that Disease: being an attempt to found its Treatment on Rational Principles. 8vo. with 2 coloured plates, 10s. London, 1843.
- COURTENAY.** PATHOLOGY and RATIONAL TREATMENT of STRICTURE of the URETHRA in all its Varieties and Complications, with observations on the Use and Abuse of Urethral Instruments. The whole illustrated by numerous Cases. By F. B. COURTENAY, M.R.C.S., &c. 4th Edition. 8vo. 5s. London, 1848.
- PRACTICAL OBSERVATIONS on the CHRONIC ENLARGEMENT of the PROSTATE GLAND in OLD PEOPLE: with Mode of Treatment. By Francis B. Courtenay, 8vo. with numerous cases and plates, boards, 7s. 6d. London, 1839.
- CRUVEILHIER AND BONAMY,** ATLAS of the DESCRIPTIVE ANATOMY of the HUMAN BODY. By J. Cruveilhier, Professor of Anatomy to the Faculty of Medicine Paris. With Explanations by C. Bonamy. Containing 82 plates of Osteology, Syndemology, and Myology. 4to. Plain, 3l; coloured, 5l. 15s. London, 1844.
- GERBER AND GULLIVER.** ELEMENTS of the GENERAL and MINUTE ANATOMY of MAN and the MAMMALIA; chiefly after Original Researches. By Professor Gerber. To which is added an Appendix, comprising Researches on the Anatomy of the Blood, Chyle, Lymph, Thymous Fluid, Tubercle, and Additions, by C. Gulliver, F.R.S. In 1 vol. 8vo. Text, and an Atlas of 34 plates, engraved by L. Aldous. 2 vols. 8vo. cloth boards, 17. 4s. 1842.
- GRANT.** GENERAL VIEW of the DISTRIBUTION of EXTINCT ANIMALS. By Robert E. Grant, M.D. F.R.S. L. & E.; Professor of Comparative Anatomy at the University College, London. In the "British Annual," 1839. 18mo. 3s. 6d. London, 1839.
- ON the PRINCIPLES of CLASSIFICATION, as applied to the Primary Divisions of the Animal Kingdom. In the "British Annual," 1838. 18mo. illustrated with 28 woodcuts, 3s. 6d. London, 1838.
- OUTLINES of COMPARATIVE ANATOMY. 8vo. illustrated with 148 woodcuts, boards, 17. 8s. London, 1835—41.
- *** Part VII, with Title-page, 1s. 6d.
- HALL, MARSHALL.** ON the DISEASES and DERANGEMENTS of the NERVOUS SYSTEM, in their Primary Forms, and in their modifications by Age, Sex, Constitution, Hereditary Predisposition, Excesses, General Disorder and Organic Disease. By Marshall Hall, M.D. F.R.S. L. & E. 8vo. with 8 engraved plates, 15s. London, 1841.
- *** As an Appendix to the above Work,—
- ON the MUTUAL RELATIONS BETWEEN ANATOMY, PHYSIOLOGY, PATHOLOGY, THERAPEUTICS, and the PRACTICE of MEDICINE; being the Gulstonian Lectures for 1842. 8vo. with 2 coloured plates and 1 plain, 5s. London, 1842.
- NEW MEMOIR on the NERVOUS SYSTEM, TRUE SPINAL MARROW, and its ANATOMY, PHYSIOLOGY, PATHOLOGY, and THERAPEUTICS. 4to. with 5 engraved plates, 17. London, 1843.

- HENRIQUES.** ETIOLOGICAL, PATHOLOGICAL and THERAPEUTICAL REFLECTIONS on the ASIATIC CHOLERA, as OBSERVED in EUROPE, ASIA MINOR, and EGYPT. 8vo. 1s. 6d. London, 1848.
- HUFELAND.** MANUAL of the PRACTICE of MEDICINE; the Result of Fifty Years' Experience. By W. C. Hufeland, Physician to the late King of Prussia; Professor in the University of Berlin. Translated from the Sixth German Edition, by C. Bruchhausen and R. Nelson. 8vo. bound, 15s. London, 1844.
- LAENNEC.** A TREATISE on the MEDIATE AUSCULTATION, and on DISEASES of the LUNGS and HEART. By R. T. H. Laennec, Professor to the College of France, and to the Faculty of Medicine of Paris. With Notes and Additions by M. Laennec, and M. Andral, Professors to the Faculty of Medicine, Paris. Translated from the last edition by a Member of the College of Physicians. Edited by Theophilus Herbert, M.D.; with Practical Notes, condensed from the Lectures of F. H. Ramadge, M.D., Oxon. 8vo. with plates, 18s. London, 1846.
- LEBAUDY,** THE ANATOMY of the REGIONS interested in the SURGICAL OPERATIONS performed upon the HUMAN BODY; with Occasional Views of the Pathological Conditions, which render the interference of the Surgeon necessary. In a Series of 24 plates, the Size of Life. By J. Lebaudy. Folio, 17 4s. London, 1845.
- LEE.** THE ANATOMY of the NERVES of the UTERUS. By Robert Lee, M.D. F.R.S. Folio, with 2 engraved plates, 8s. London, 1841.
- MADDOCK.** PRACTICAL OBSERVATIONS on the EFFICACY of MEDICATED INHALATIONS in the TREATMENT of PULMONARY CONSUMPTION. By Dr. Maddock. 3rd Edition, 8vo. with a coloured plate, 5s 6d. London, 1846.
- CASES of PULMONARY CONSUMPTION, BRONCHITIS, ASTHMA, CHRONIC COUGH,** and various diseases of the Lungs, successfully treated by Medicated Inhalations, 8vo. London, 1847. 2s.
- MARTIN.** A GENERAL INTRODUCTION to the NATURAL HISTORY of MAMMIFEROUS ANIMALS: with a particular View of the Physical History of Man, and the more closely allied Genera of the Order "Quadrumana," or Monkeys. Illustrated with 296 Anatomical, Osteological, and other engravings on wood, and 12 full-plate Representations of Animals, drawn by W. Harvey. 1 vol. 8vo. 16s London, 1841.
- OWEN.** ODONTOGRAPHY; or, a Treatise on the Comparative Anatomy of the Teeth their Physiological Relations, Mode of Development, and Microscopical Structure in the Vertebrate Animals. By Richard Owen, F.R.S. Correspondent of the Royal Academy of Sciences, Paris and Berlin; Hunterian Professor to the Royal College of Surgeons, London. This splendid Work is now completed, 2 vols. royal 8vo. containing 168 plates, half bound russet, 67 6s. London, 1840-45.
- A few copies of the plates have been printed on India paper, 2 vols. 4to. 107. 10s.
- PHILLIPS.** SCROFULA: its Nature, its Prevalence, its Causes, and the Principles of Treatment. By Benjamin Phillips, F.R.S. Surgeon and Lecturer on Surgery to the Westminster Hospital. 1 vol. 8vo. with an engraved plate, 12s. London, 1846.
- "This is one of the few books which may be said to be after the critic's own heart. It is a book that was wanted; the object of it is excellent, it has been carefully planned; the investigations required by the plan have been conducted with the utmost energy, industry and carefulness, in a sufficiently extensive field, and over a sufficiently long period of time; the immense mass of materials thus obtained has been examined and weighed with the greatest attention and impartiality; the inferences and results have been honestly and cautiously deduced and elaborated, and condensed into the smallest possible space consistent with perspicuity; while the whole style and manner of the composition is such as ought to characterise the production of a well-educated, a learned, and an experienced surgeon."—*British and Foreign Medical Review.*
- PHILLIPS.** A TREATISE on the URETHRA; its Diseases, especially Stricture, and their Cure. 8vo. boards. London, 1832. 8s.
- PRICHARD.** THE NATURAL HISTORY of MAN; comprising Inquiries into the Modifying Influence of Physical and Moral Agencies on the different Tribes of the Human Family. By James Cowles Prichard, M.D. F.R.S. M.R.I.A. Corresponding Member of the National Institute, of the Royal Academy of Medicine, and of the Statistical Society of France; Member of the American Philosophical Society, &c. &c. 3rd Edition, enlarged, with 50 coloured and 5 plain illustrations, engraved on steel, and 97 engravings on wood, royal 8vo. elegantly bound in cloth. 17. 16s. London, 1848.
- APPENDIX to the FIRST and SECOND EDITIONS of the NATURAL HISTORY of MAN.** Large 8vo. with 6 coloured plates, each 3s. 6d. London, 1845, & 1848.
- SIX ETHNOGRAPHICAL MAPS,** as a Supplement to the Natural History of Man, and to the Researches into the Physical History of Mankind. Folio, coloured, and 1 sheet of letter-press, 21s; bound in cloth boards, 24s. London, 1845.
- ILLUSTRATIONS to the RESEARCHES into the PHYSICAL HISTORY of MANKIND.** Atlas of 44 coloured and 5 plain plates, engraved on steel, large 8vo. half-bound. 18s. London, 1841.
- ON the DIFFERENT FORMS of INSANITY,** in relation to Jurisprudence. (Dedicated to the Lord Chancellor of England.) 12mo. 5s. London, 1842.
- RAYER.** A THEORETICAL and PRACTICAL TREATISE on the DISEASES of the SKIN. By P. Rayer, M.D., Physician to the Hôpital de la Charité. Translated by R. Willis, M.D. 2nd Edition, remodelled and much enlarged, in 1 thick vol. 8vo. of 1300 pages, with atlas, royal 4to. of 26 plates, finely engraved, and coloured with the greatest care, exhibiting 400 Varieties of Cutaneous Affections, 47. 8s; the text separately, 8vo. in boards, 17. 8s; the atlas 4to. separately, in boards, 37. 10s. London, 1835.

- ROBINSON.** SURGICAL, MECHANICAL, and MEDICAL TREATMENT of the TEETH, including Dental Mechanics, with 139 engravings. By James Robinson, Surgeon Dentist to the Metropolitan Hospital. Post 8vo. cloth, 10s. London, 1846.
- RYAN.** THE PHILOSOPHY of MARRIAGE, in its Social, Moral, and Physical Relations; with an Account of the Diseases of the Genito-Urinary Organs, with the Physiology of Generation in the Vegetable and Animal Kingdoms. By M. Ryan, M.D. 4th edition, greatly improved, 1 vol. 12mo. 6s. London, 1843.
- SHUCKARD.** ESSAY on the INDIGENOUS FOSSIL HYMENOPTERA; comprising a Description of the British Species of Burrowing Sand Wasps contained in all the Metropolitan Collections; with their habits as far as they have been observed, 8vo. with 4 plates. London, 1837. 10s.
Plate I. is wanting.
- SYME.** PRINCIPLES of SURGERY. By J. Syme, Professor of Clinical Surgery in the University of Edinburgh. 3rd edition, much enlarged, and illustrated with 14 plates on India paper, and 64 woodcuts. 1 vol. 8vo. 21s. London, 1842.
- VOGEL AND DAY.** THE PATHOLOGICAL ANATOMY of the HUMAN BODY. By Julius Vogel, M.D. Translated from the German, with additions, by George E. Day, M.D. Illustrated with upwards of 100 plain and coloured engravings, 8vo. cloth, 18s. London, 1847.
- WARDROP.** ON BLOOD-LETTING; an Account of the Curative Effects of the Abstraction of Blood; with Rules for employing both local and general Blood-Letting in the treatment of Diseases. 12mo. 4s. London, 1835.
- WATERHOUSE.** A NATURAL HISTORY of the MAMMALIA. By G. R. Waterhouse, Esq., of the British Museum. Vol. I, containing the Order Marsupialia, or Pouched Animals, with 22 illustrations, engraved on steel, and 18 engravings on wood, royal 8vo. elegantly bound in cloth, coloured plates, 1l. 14s. 6d.; plain, 1l. 9s.
Vol. II, containing THE ORDER RODENTIA; or, GNAWING MAMMALIA: with 22 illustrations, engraved on steel, and engravings on wood, royal 8vo. elegantly bound in cloth. Price, 1l. 9s. plain; 1l. 14s. 6d. coloured. London, 1848.
The Natural History of Mammalia is intended to embrace an account of the structure and habits of all the known species of Quadrupeds, or Mammals; to which will be added, observations upon their geographical distribution and classification. Since the fossil and recent species illustrate each other, it is also intended to include notices of the leading characters of the extinct species.
The Genera, and many of the species are illustrated by engravings on steel, and by woodcuts. The modifications observable in the structure of the skulls, teeth, feet, and other parts, are almost entirely illustrated by steel engravings.
- WILLIAMS.** ELEMENTS of MEDICINE: Morbid Poisons. By Robert Williams, M.D. Physician to St. Thomas's Hospital. 2 vols. 8vo. 1l. 8s. 6d. London, 1836—41.
** Vol. II. separately, 18s. 1841.
- WILLIS.** ILLUSTRATIONS of CUTANEOUS DISEASE: a Series of Delineations of the Affections of the Skin, in their more interesting and frequent forms: with a Practical Summary of their Symptoms, Diagnosis, and Treatment, including appropriate Formulæ. By Robert Willis, M.D., Member of the Royal College of Physicians. The Drawings are after Nature, and Lithographed by Arch. Henning. These Illustrations are comprised in 94 Plates, folio. The Drawings are Originals, carefully coloured. Bound in cloth, lettered, 6l. London, 1842.
- ON the TREATMENT of STONE in the BLADDER by Medical and Mechanical Means. 8vo. 5s. London, 1843.
- VENABLES.** THE NATURE and TREATMENT of the EPIDEMIC or ASIATIC CHOLERA; with Simple Directions for the Suppression and Prevention of the Disease. 4th Edition. 12mo. London, 1848. 2s. 6d.

BOTANY.

- BABINGTON.** PRIMITIÆ FLORÆ SARNICÆ; or an Outline of the Flora of the Channel Islands of Jersey, Guernsey, Alderney, and Serk. 12mo. 4s. London, 1839.
- FIELDING AND GARDNER.** SERTUM PLANTARUM; or, Drawings and Descriptions of Rare and Undescribed Plants from the Author's Herbarium. By H. B. Fielding; assisted by G. Gardner, Superintendent of the Royal Botanic Gardens, Ceylon. 8vo. 1l. 1s. London, 1844.
- HOOKE.** ICONES PLANTARUM. By Sir W. J. Hooker, Director of the Royal Botanic Gardens, Kew. New Series, Vols. I—IV, containing each 100 plates with explanations. 8vo. cloth, each vol. 1l. 8s. London, 1842—1844, 8s.
** Vol. IV. Part 2. 14s. London, 1848.
- THE LONDON JOURNAL of BOTANY. Vols. I—VI, with 24 plates each, boards, each vol. 1l. 10s. 1842—47.
- NOTES on the BOTANY of the ANTARCTIC VOYAGE, conducted by CAPT. JAMES CLARK ROSS, R.N. F.R.S., in H.M.S.S. *Erebus* and *Terror*; with Observations on the Tussac Grass of the Falkland Islands. 8vo. with 2 coloured plates, 4s. London, 1843.
- MATEER (W.)** OUTLINES of BOTANY. Part 1, with 7 plates, 12mo. cloth boards. 2s. 6d. London, 1848.
- MIERS (J.)** ILLUSTRATIONS of SOUTH AMERICAN PLANTS. 4to. with 16 plates London, 1847. 14s.

- SCHLEIDEN. THE PLANT;** a Biography, in a Series of Popular Lectures on Botany. Edited and Translated by A. Henfrey, F.L.S. 8vo. with 5 coloured plates, and 13 woodcuts, 15s. London, 1848.
- WIGHT. ILLUSTRATIONS of INDIAN BOTANY;** or Figures Illustrative of each of the Natural Orders of Indian Plants, described in the Author's Prodomus Floræ Peninsulae Indiæ Orientalis; but not confined to them. By Dr. R. Wight, F.L.S. Surgeon to the Madras Establishment. Vol. 1, published in 13 parts, containing 95 coloured plates, 4l. 17s. 6d. Madras, 1838—40.
Vol. 2, Part 1, containing 39 coloured plates, 1l. 5s. Madras, 1841.
*** *Odd Parts can be obtained to complete sets.*
- ICONES PLANTARUM INDIE ORIENTALIS;** or Figures of Indian Plants. By Dr. Robert Wight, F.L.S. Surgeon to the Madras Establishment. Vol. 1, 4to. consisting of 16 Parts, containing together 318 plates. 4l. Madras, 1838—40.
Vol. 2, consisting of 4 Parts, containing together 318 plates, 5l. 5s. Madras, 1840—42.
Vol. 3, Parts 1 to 4, with 509 plates, 6l. Madras, 1843—47.
Vol. 4, Part 1, with 125 plates, 1l. 10s. Madras, 1848.
*** *Odd Parts may be obtained to complete sets.*
- CONTRIBUTIONS to the BOTANY of INDIA.** By Dr. Robert Wight, F.L.S. Surgeon to the Madras Establishment. 8vo. 7s. 6d. London, 1834.
- SPICILEGIUM NEILGHERRENSE;** or, a Selection of Neilgherry Plants, Drawn and Coloured from Nature, with Brief Descriptions of each; some General Remarks on the Geography and Affinities of Natural Families of Plants, and Occasional Notices of their Economical Properties and Uses. By Dr. Robert Wight, F.L.S. Surgeon to the Madras Establishment. 4to. with 100 coloured plates, 3l. 5s. Madras, 1846.
- PRODROMUS FLORÆ PENINSULÆ INDIE ORIENTALIS;** containing Abridged Descriptions of the Plants found in the Peninsula of British India, arranged according to the Natural System. By Drs. Robert Wight, F.L.S., and Walker Arnott. Vol. 1, 8vo. 16s. London, 1834.

HOMŒOPATHIC.

- ARNICA AND RHUS,** With Directions for their Use in Mechanical Injuries and in other Affections. 18mo. 1s. London, 1848.
- BELLUOMINI (J., M.D.) SCARLATINA;** its Treatment Homœopathically. 8vo. 1s. London, 1843.
- BENNINGHAUSEN. MANUAL of HOMŒOPATHIC THERAPEUTIC,** intended as a Guide to the Study of MATERIA MEDICA PURA. Translated, with Additions, by S. Laurie, M.D. 8vo. 12s. 1848.
- BLACK. THE HOMŒOPATHIC TREATMENT OF CHOLERA.** 8vo. 1847. 1s.
A TREATISE ON THE PRINCIPLES OF HOMŒOPATHY. 8vo. London, 1842. 9s.
- CHEPMELL. A DOMESTIC HOMŒOPATHY,** Restricted to its Legitimate Sphere of Practice; together with Rules for Diet and Regimen. 18mo. London, 1848. 4s. 6d.
- CURIE (P. F., M.D.) PRACTICE of HOMŒOPATHY.** 1 vol. 8vo. 6s. London, 1838.
PRINCIPLES of HOMŒOPATHY. 1 vol. 8vo. 5s. London, 1837.
JAHR'S HOMŒOPATHY. New Edition, 2 vols. 12mo. 1l. 12s. London, 1847
*** *See JAHR.*
- DUNSFORD (HARRIS.) THE PATHOGENETIC EFFECTS of SOME of the PRINCIPAL HOMŒOPATHIC REMEDIES.** 8vo. 3s. London, 1838.
- THE PRACTICAL ADVANTAGES of HOMŒOPATHY,** illustrated by numerous Cases. Dedicated, by permission, to Her Majesty Queen Adelaide. 1 vol. 8vo. 8s. boards. 1841.
- EPHS. DOMESTIC HOMŒOPATHY;** or, Rules for the Domestic Treatment of the Maladies of Infants, Children, and Adults, and for the Conduct and Treatment during Pregnancy, Confinement, and Suckling. 4th Edition, 12mo. 4s. 6d. London, 1844.
- EVEREST (T. R.) A POPULAR VIEW of HOMŒOPATHY;** exhibiting the Present State of the Science. 2nd Edition, amended and much enlarged. 8vo. 6s. London, 1836.
A LETTER addressed to the Medical Practitioners of Great Britain on the Subject of Homœopathy. 8vo. 1s. 6d. London, 1834.
- GUNTHER. NEW MANUAL of HOMŒOPATHIC VETERINARY MEDICINE;** or, the Homœopathic Treatment of the Horse, the Ox, the Dog, and other Domestic Animals. Translated from the 3rd German Edition, with considerable Additions and Improvements. Post 8vo. 10s. 6d. cloth. London, 1847.
- JAHR. MANUAL of HOMŒOPATHIC MEDICINE.** In 2 Parts. Part I.—MATERIA MEDICA. Part II.—THERAPEUTICAL and SYMPTOMATOLOGICAL REPOSITORY. Translated from the 4th Edition, and Edited, with Additions, by P. F. Curie, M.D. 2 vols. 8vo. 1l. 12s. London, 1847.

The most complete Work on the subject.

SHORT ELEMENTARY TREATISE upon HOMŒOPATHY and its PRACTICE; with some of the most important Effects of Ten of the Principal Homœopathic Remedies. Translated by E. Bayard, M.D. 18mo. 2s. 6d. London, 1846.

- HAHNEMANN.** MATERIA MEDICA PURA. Translated and Edited by Charles J Hempel, M.D. Vols. 1 to 4, 8vo. 8s. each. New York, 1846.
- ORGANON OF HOMŒOPATHIC MEDICINE.** 2nd Edition, 8vo. 10s. 6d. New York, 1843.
- THE CHRONIC DISEASES,** their Specific Nature and Homœopathic Treatment. Translated and Edited by Charles J. Hempel, M.D., 5 vols. 12mo. 2l. New York, 1846.
- HAMILTON.** A GUIDE TO THE PRACTICE OF HOMŒOPATHY. Translated and compiled, in alphabetical order, from the German of Ruoff, Haas, and Rückert, with Additions. 12mo. 5s. Leipzig, 1844.
- HARRAL (F. BLAGDON).** POPULAR OUTLINES OF HOMŒOPATHY. 24mo. 1s. London, 1840.
- HARTMANN (F.)** SPECIAL THERAPEUTICS; or, the Homœopathic Treatment of the Acute and Chronic Diseases. Translated from the 3rd German Edition. 2 vols. 8vo. London, 1847.
- PRACTICAL OBSERVATIONS** on SOME of the CHIEF HOMŒOPATHIC REMEDIES. Translated from the German, with Notes, by Dr. Okie. 2 vols. 12mo. 10s. New York, 1846.
- HAYLE.** AN ADDRESS on the HOMŒOPATHIC SYSTEM of MEDICINE. 8vo. 1s. 1843.
- HERING** (of Philadelphia). THE HOMŒOPATHIST; or, Domestic Physician. 2nd Edition. 12mo. 7s. London, 1845
- HOMŒOPATHIC EXAMINER (THE),** By Drs. Gray and Hempel. Newseries. Vols. I. and II., each, 30s. New York, 1846—1847.
- LAURIE (M.D.)** HOMŒOPATHIC DOMESTIC MEDICINE. 4th Edition, 12mo. 12s. London, 1847.
- ELEMENTS OF HOMŒOPATHIC PRACTICE OF PHYSIC.** 8vo. 1847. 16s.
- NEWMAN (GEORGE).** HOMŒOPATHIC FAMILY ASSISTANT. Second Edit. 1847. 5s.
- A CONCISE EXPOSITION OF HOMŒOPATHY;** its Principles and Practice with an Appendix. 1s. 6d.
- ROSENSTEIN (J. G.)** THE COMPARATIVE MERITS OF ALLŒOPATHY; the old Medical Practice, and Homœopathy, the reformed Medical Practice; practically illustrated 8vo. 8s. Montreal, 1846.
- RUOFF.** REPERTORY OF HOMŒOPATHIC MEDICINE, Nosologically arranged. Translated from the German by A. H. Okie, with additions and improvements by G. Humphrey, M.D. 12mo. 7s. New York, 1843.
- SIMPSON (M.D.)** PRACTICAL VIEW of HOMŒOPATHY. 8vo. 10s. 6d. London, 1836.
- WHITEFIELD.** HOMŒOPATHY the TRUE ART of HEALING. 18mo. 6d. Brighton, 1845.

MESMERISM.

- ASHBURNER (J.)** FACTS IN CLAIRVOYANCE, with Observations on Mesmerism, and its Application to the Philosophy of Medicine, and to the Cure of Diseases. 8vo. 1s. London, 1848.
- DAVIS.** THE PRINCIPLES OF NATURE, her Divine Revelations and a Voice to Mankind. 2 vols. 8vo. London, 1847. 18s.
- EARLY MAGNETISM,** in its HIGHER RELATIONS to HUMANITY; as veiled in the Poets and the Prophets. By ΘΥΟΣ ΜΑΘΟΣ. 8vo. cloth. 5s. London, 1846.
- ELLIOTSON.** THE HARVEIAN ORATION, delivered before the Royal College of Physicians, London, June 27, 1846. By John Elliotson, M.D. Cantab. F.R.S.; Fellow of the College. 8vo. with an English Version and Notes, 2s. London, 1846.
- NUMEROUS CASES OF SURGICAL OPERATIONS WITHOUT PAIN** in the MESMERIC STATE; with Remarks upon the Opposition of many Members of the Royal Medical and Chirurgical Society, and others, to the reception of the inestimable blessings of Mesmerism. By John Elliotson, M.D. Cantab. F.R.S. 8vo. 2s. 6d. London, 1843.
- A FINE PORTRAIT** of, Engraved on stone, 4s. 6d. London, 1844.
- ENGLEDUE.** CEREBRAL PHYSIOLOGY and MATERIALISM; with the Result of the Application of Animal Magnetism to the Cerebral Organs. By W. C. Engledue, M.D. With a Letter from John Elliotson, M.D., on Mesmeric Phrenology and Materialism. 8vo. 1s. London, 1842.
- HALL (SPENCER T.)** MESMERIC EXPERIENCES. 12mo. 2s. 6d. 1845.
- JONES.** THE CURATIVE POWER of VITAL MAGNETISM; verified by Actual Application to numerous Cases of Diseases. 12mo. 1s. London, 1845.
- KISTE.** MESMERISM; or, Facts against Fallacies. In a Letter to the Rev. George Sandby. 18mo. 1s. London, 1845.
- SANDBY.** MESMERISM and its OPPONENTS. 2nd edition, 12mo. 1848. 5s.
- STORER.** MESMERISM in DISEASE; a Few Plain Facts, with a selection of Cases. By Henry Storer, M.D. 2nd Edition, 12mo. 2s. 6d. London, 1845.

TESTE. A PRACTICAL MANUAL of ANIMAL MAGNETISM; containing an Exposition of the Methods employed in producing the Magnetic Phenomena, with its Application to the Treatment and Cure of Diseases. By A. Teste, M.D. Translated from the 2nd Edition, by D. Spillan, M.D. Dedicated, with permission, to John Elliotson, M.D. Cantab, F.R.S. 1 vol. post 8vo. 6s. London, 1843

TOPHAM and WARD. ACCOUNT of a CASE of SUCCESSFUL AMPUTATION of the THIGH DURING the MESMERIC STATE, without the Knowledge of the Patient. Read to the Royal Medical and Chirurgical Society on the 22nd November, 1842. 8vo. 1s.

TOWNSEND. FACTS in MESMERISM, with Reasons for a Dispassionate Inquiry into it. By the Rev. Ch. H. Townsend. 2nd Edition, with a New Preface, and enlarged. 8vo. 9s. London, 1844.

ZOIST. A JOURNAL of CEREBRAL PHYSIOLOGY and MESMERISM, and their Application to Human Welfare. Published Quarterly, each Number, 2s. 6d.

** This Journal contains papers by Drs. Elliotson, Engledue, Ashburner, &c. &c.

Twenty-three Numbers have already appeared.

Nos. 1 to 20, cloth boards, 5 vols. 8vo. 2l. 15s.

Commenced April 1, 1843.

BULWER LYTTON (SIR E.) CONFESSIONS OF A WATER PATIENT. 3rd Edition, 1847. 1s.

WILSON. PRACTICE OF THE WATER CURE, with authenticated Evidence of its Efficacy and Safety. Part I. containing 70 authenticated Cases, the Opinions of English Medical Practitioners, a Sketch of the History and Progress of the Water Cure, and an Account of the Processes used in the Treatment. 8vo. 1s. 6d. London, 1844.

WILSON. THE WATER CURE, Stomach Complaints, and Drugs, Diseases, their Causes, Consequences, and Cure by Water, Air, Exercise, and Diet. 8vo. 3rd Edition, 1843. 4s. 6d.

BONIFACE. MODERN ENGLISH and FRENCH CONVERSATION; containing Elementary Phrases, and New Easy Dialogues, in French and English, on the most familiar Subjects: for the use of the Traveller and Student. By M. Boniface. 16th Edition, 18mo. 3s. London, 1845.

OLLENDORFF. A NEW METHOD of LEARNING to READ, WRITE, and SPEAK the GERMAN LANGUAGE in SIX MONTHS. By H. G. Ollendorff. Translated from the Fifth French Edition. By G. J. Bertinchamp, A.B. 3rd Edition, revised and considerably improved. 12mo. bound, 9s. 1843.—Also,

A KEY to the EXERCISES. 12mo. bound, 4s. 6d. 1848.

TROPFANEGGER. GERMAN GRAMMAR; or, the Grammatical Forms of the German Language, and the Construction of Sentences; with Reading Lessons and Exercises. 3rd Edition, 12mo. 5s. London, 1844.

RAYMOND DE VERICOUR. PRINCIPLES OF HISTORY. 12mo. 1s. 6d. London, 1845.

WIGLESWORTH (THOMAS). TABLES of the Logarithm of the Probability of a Life of any assigned age living to any other age, according to the experience of the Carlisle Table of Mortality. 8vo. 5s. London, 1848.

VITAL STATISTICS. An Essay on the rate of Mortality among Children. 8vo. 2s. 6d. London, 1847.

WRAY. THE PRACTICAL SUGAR PLANTER; a Complete Account of the Cultivation and Manufacture of the Sugar Cane, according to the latest and most Improved Processes. By Leonhard Wray, Esq. 8vo. 1l. 1s. 1848.

LIBRARY
OF ILLUSTRATED
STANDARD SCIENTIFIC WORKS.

UNDER this Title the Publisher has already issued seven volumes, as detailed in the following Prospectus, all printed in a fine type, in the octavo form, and illustrated in the most efficient manner.

It is intended that this Series shall embrace Works in the various branches of Science by the most distinguished men in their respective departments. Several are now in actual preparation.

No expense has been, nor will be spared, to make this series of Works, worthy of the support of the Scientific public.

219, REGENT STREET, LONDON.

H. BAILLIERE.

I.

PROFESSOR MULLER'S

PRINCIPLES OF PHYSICS AND METEOROLOGY.

WITH 530 WOODCUTS AND 2 COLOURED ENGRAVINGS. 8vo. 18s.

II.

PROFESSOR WEISBACH'S

MECHANICS OF MACHINERY AND ENGINEERING.

VOLS. I. AND II WITH 900 WOODCUTS. £1. 19s.

III.

PROFESSOR KNAPP'S

TECHNOLOGY; OR,

CHEMISTRY APPLIED TO THE ARTS AND TO MANUFACTURES.

EDITED BY DR. E. RONALDS AND DR. T. RICHARDSON,

Vols. I. and II. splendidly Illustrated. Price £2. 2s.

IV.

QUEKETT (JOHN).

PRACTICAL TREATISE ON THE USE OF THE MICROSCOPE.

With Steel and Wood Engravings. 8vo. 21s.

V.

PROFESSOR GRAHAM'S

ELEMENTS OF CHEMISTRY, WITH ITS APPLICATION IN THE ARTS.

Second Edition, with upwards of 1200 Pages of Letter-Press and innumerable Woodcuts.

IN THE PRESS.

A COMPLETE TREATISE ON METALLURGY,
AND THE CHEMISTRY OF THE METALS.

BY DR. E. RONALDS AND DR. T. RICHARDSON,

Editors of "KNAPP'S TECHNOLOGY."

FORMING VOL. III. OF WEISBACH'S MECHANICS.

THE STEAM ENGINE.

BY PROFESSOR L. GORDON, OF GLASGOW.

Giving all the Improvements to the Present Time. Beautifully Illustrated on Steel and Wood.

0





Biol
Micros.
Q

Quekett, John
Practical treatise on the
use of the microscope

PLEASE DO NOT REMOVE
CARDS OR SLIPS FROM THIS POCKET

UNIVERSITY OF TORONTO LIBRARY
